

UNIVERSITY OF CAPE COAST

FACTORS INFLUENCING PARENTS' CHOICE OF A SENIOR HIGH  
SCHOOL FOR THEIR CHILDREN

JAMES AMONOO

2014

UNIVERSITY OF CAPE COAST

FACTORS INFLUENCING PARENTS' CHOICE OF A SENIOR HIGH  
SCHOOL FOR THEIR CHILDREN

BY

JAMES AMONOO

Thesis submitted to the Department of Educational Foundations of the College of Education Studies, University of Cape Coast, in partial fulfilment of the requirements for award of Master of Philosophy Degree in Sociology of Education

JUNE 2014

## DECLARATION

### **Candidate's Declaration**

*I hereby declare that this thesis is the result of my own original research and that no part of it has been presented for another degree in this university or elsewhere.*

Candidate's Signature: ..... Date: .....

Name: James Amonoo

### **Supervisors' Declaration**

*We hereby declare that the preparation and presentation of the thesis were supervised in accordance with the guidelines on supervision of thesis laid down by the University of Cape Coast.*

Principal Supervisor's Signature: ..... Date: .....

Name: Prof. James Adu Opare

Co-supervisor's Signature: ..... Date: .....

Name: Mr. John Anaesi Yarquah

## ABSTRACT

The purpose of the study was to identify the pertinent factors affecting parents' choice of a particular senior high school in Ghana. Specifically, the study examines the type of schools parents in the Cape Coast Metropolis choose for their children, and some of the school's institutional factors that parents look for in deciding the choice of a particular school for their children.

The design used for the study was descriptive survey design. A total of 294 parents completed the questionnaire. The lottery method of simple random sampling procedure was used first to select 14 senior high schools, while the census method was used to capture all the parents who stay in Cape Coast and have at least one children in the selected schools. Cronbach's alpha was used to find out the reliability of the instrument. The reliability coefficient was 0.762. The data for the study were analysed using cross tabulation, frequency, percentage, means, median, standard deviation, skewness, Pearson Product Moment correlation and multiple regression procedures.

The study found out that parents preferred single-sex education which is boarding and public. Parents also preferred schools with qualified teachers, excellent academic record, and adequate support services. Schools institutional factors, parents' socio-economic status and social network factors contribute significantly and positively to parents' choice of a particular SHS. It is recommended to parents that they should request from the management of the school to ensure that teachers will develop and maintain positive attitude towards students. Also, heads of the various schools should be attentive to the various institutional factors and create schools that address the needs of the parents in their communities if they are to attract and retain students.

## ACKNOWLEDGEMENTS

The success of this thesis is due to the help, encouragement and support I got from many people. I am greatly indebted to all of them. First, I would like to express my gratitude to Professor James Adu Opare, my principal supervisor, for making constructive criticisms and invaluable suggestions that have made it possible for this work to be completed. But for his patience, time, fatherly love and belief in me it would have been difficult to complete this research on schedule. I thank him and pray that his doors will always be open to all.

Second, I am deeply indebted to Mr. John Anaesi Yarquah, my co-supervisor for his patience, interest and invaluable contributions in reading and correcting this thesis. I am highly indebted to my wife, Frances Amonoo, whose prayers, sacrifice, support and encouragement spurred me on to the successful completion of this work.

Third, my heartfelt gratitude goes to my mother, Mrs. Mary Amonoo for her motherly love and support. Without her understanding and sacrifice I would not have completed this work. I would like to register my sincere appreciation to my child, Brynn Kobina Seyram Amonoo, for his understanding of my absence from the house to campus most of the time to attend lectures and other issues related to my research work.

My deepest gratitude goes to Mr. John Amonoo and Esther Amonoo for their brotherly love and support. Without their understanding and sacrifice, I would not have completed this work. Finally, I wish to thank my colleagues, family and friends for their support, especially, Abdul-Jaleel Saani.

## **DEDICATION**

To my father and wife.

## TABLE OF CONTENTS

	Page
DECLARATION	ii
ABSTRACT	iii
ACKNOWLEDGEMENTS	iv
DEDICATION	v
LIST OF TABLES	ix
LIST OF FIGURES	x
CHAPTER	
ONE INTRODUCTION	1
Background to the Study	1
Statement of the Problem	6
Purpose of the Study	7
Research Questions	8
Research Hypotheses	8
Significance of the Study	9
Delimitation of the Study	10
Limitations of the Study	11
Organisation of the Rest of the Study	11
TWO REVIEW OF RELATED LITERATURE	13
School Choice	13
Parental Choice	20
Theories of School Choice	21
Options in School Choice in Ghana	23

	The Growth of Public and Private Education in Ghana	24
	Factors to Consider When Choosing a Senior High School	24
	Parents' Socio-Demographic Background	37
	Empirical Studies on Parental Choice in Education	41
	Understanding School Choice in a Developing Country	
	Context	57
	Conceptual Framework	59
THREE	METHODOLOGY	63
	Research Design	63
	Population	65
	Sample and Sampling Procedure	65
	Instrument	67
	Data Collection Procedure	72
	Data Analysis	74
FOUR	RESULTS AND DISCUSSION	76
	Background Characteristics of Respondents	77
	Analyses Pertaining to the Research Questions and	
	Hypotheses	80
	Research Question One	81
	Research Question Two	83
	Research Question Three	85
	Research Question Four	95
	Testing of the Hypotheses	97



FIVE	SUMMARY, CONCLUSIONS AND	
	RECOMMENDATIONS	102
	Summary	102
	Overview of the Study	102
	Key Findings	103
	Conclusions	106
	Recommendations	106
	Recommendations for Policy and Practice	
	Suggestions for Further Research	107
	REFERENCES	109
	APPENDICES	123
	A Questionnaires for Parents' in the Cape Coast Metropolis	124

## LIST OF TABLES

Table		Page
1	Computed Reliability Co-efficient of the Instrument	71
2	Distribution of Respondents by Highest Level of Education	77
3	Distribution of Respondents by the Number of Children	78
4	Distribution of Respondents by Family Employment Status	79
5	Distribution of Respondents by Income Level	80
6	Factors Influence Parents' Choice of a Particular SHS for their Children	82
7	Parents' Choice of Type of Senior High School	84
8	Schools' Institutional Factors that Influence Parents' Choice of a Particular SHS for their Children	87
9	Parents' Perception of Schools' Institutional Factors, their Socio-Economic and Social Factors when Choosing an SHS for their Children	96
10	Relationship among Institutional Factors, Parents' Socio-Economic Status and Social Network Factors	99

## LIST OF FIGURE

Figure		Page
1	Conceptual framework for factors that influence parents' choice of a SHS for their children	60

## **CHAPTER ONE**

### **INTRODUCTION**

#### **Background to the Study**

Education is seen as the great equaliser, the key to a better future for all citizens. The search for quality education is a quest that seems to have no end. Today, Ghana and other developing countries are analysing their ability to compete in a global economy. Societies are concerned about their short and long-term security. Families are seeking quality opportunities for their children. According to Addae-Mensah (2000), the most recognised and easy way of providing long-term security and quality opportunities to the future generation is through education. Invariably, the focus of this discussion is education. In that case both public and private school systems appear to be fair game for criticism (Teske, Schneider, Buckley & Clark, 2000).

Public education has become a highly politicised issue in most countries including developed countries (Peebles, 2000). As a result, massive education reforms have been initiated in many countries. Among these efforts is the open school choice option. School choice and a few reforms have also aroused so much public controversy in most developing countries (Finn, 2001). Despite the fact that choice is in reality a generic term that covers a wide variety of governance options, the school choice option basically rests on the fundamental assumption

that public education will not improve until it becomes more competitive, less bureaucratic, and more consumer oriented (Cookson, 2002).

For the school choice advocate, the argument is clear that government should create a fair ground for parents to choose which type of school they want for their children. Therefore, the situation where public schools in most countries have exclusive control over public education resources as compared to private schools (Kolderie, 2002) and the allocation and distribution of public funds should not be the case since such a situation will lead to the benefit of public schools over private schools with regard to parents' choice of school. In Ghana, the situation is too skewed because more than 90 percent of government resources on education with regard to secondary education go to the public senior high schools (Ministry of Education [MoE], 2009).

According to Kolderie (2002), the school choice advocates are of the view that public schools are interested only in maintaining their monopoly and the status quo. School choice opponents view school choice reforms as an attempt to dismantle the entire education system. They contend that the result of such policies will segregate schools and lead to the greater polarisation of society (Friedman, 2003).

According to Kolderie (2002), most traditional public schools in America have their best and brightest students swept away and only the children of parents unequipped to make sound educational decisions remain in public senior high schools. In Ghana this situation is otherwise. Majority of the public SHSs built by the various religious denominations and some selected government SHSs such as

St. Augustine's College, Wesley Girls High School, Tamale SHS and Ghana National College have their best students from some of the best known private basic schools in the country. Even though some of these private basic schools have their own SHSs, parents' preferred choices, when it comes to secondary education, are the public SHSs. This situation that allows students to move from private to public or the other way round may produce children who are enlightened and are involved in a democratic process (Shanker & Rosenberg, 2004).

The idea of school choice is not new in Ghana. School choice in this context, basically means the opportunities given to parents to handpick a particular school that best serves their values of education and their family needs as well. Parents in Ghana have a choice of sending their children to public schools, private schools, coeducation and single sex education (Baafi-Frimpong & Yarquah, 2001); though government or public senior high schools (SHSs) have the largest market share (68%) of total student enrolments in most developing countries (Kelley & Evans, 2004). However, over the past 25 years (1979 – 2004), government schools in most developing countries have suffered a loss of 11 percent market share (83,000 students) and private schools have seen a large increase (nine percent) in student enrolment (459,000 students) (Australian Bureau of Statistics [ABS], 2004).

These developments illustrate that schooling has developed to become a service industry with parents becoming customers in selecting a school for their children. Parents take into consideration many issues when choosing a SHS for

their children. One of the major issues they consider is the planning of getting all the benefits and achievement for their children's future and the total cost they must pay (Coulson, 2005; Jackson & Bisset, 2005). According to Dahari and Ya (2011), the best known elements that influence parents' choice of secondary education can be grouped into two main factors. These are institutional factors and parents' socio-economic status. Yarquah, Baafi-Frimpong and Atta (2011) also made mention of social network factors as one of the main factors that influence parents' choice of secondary education. Some of the institutional factors include the programmes offered, quality of teachers, cleanliness and hygiene, excellent academic record and discipline in the school. On the other hand, parents' socio-economic status includes educational level and household income. These factors are among many others which this study will survey to determine which of them have influence on parents' choice of a SHS for their children.

Many parents in Ghana are in a dilemma when it comes to choosing an SHS for their children, therefore it is important for parents to consider the factors and determine their priorities when it comes to their choice of secondary education (Oketch & Ngware, 2010). Parents have different educational beliefs and perceptions which influence the choice of SHS for their children. There are also constraints that may force a parent to choose an SHS that is less preferred, because of availability and affordability. Some parents could be persuaded by bogus claims made by influential people in the society, their neighbours and the fact that they themselves are old students of the school (Dahari & Ya, 2011).

If the various factors could be identified it would be helpful for parents to decide on a SHS choice for their children. With changing consumer patterns traditional SHS operators are losing their market to modern SHS that have been upgraded into model schools, international schools or colleges and with modern and industrially related curricula. Studying modern parents' choice of high schools and why they choose them would enable SHS operators to understand and cater for their consumers' needs and preferences. Both public and private SHSs and also the international schools in Ghana must adopt certain marketing strategies that seek to provide more values than their competitors. To achieve this they must study parents' choice, their needs and desires in order to retain their loyalty (Hawkins, Mothersbaugh & Best, 2007). Specifically, the study seeks to examine the factors that motivate parents to prefer a particular SHS to others. This study was designed to identify particular primary and secondary variables that parents make use of, and refer to during the choice process.

Many previous researchers focus on only the institutional factors and their influence on parents' choice (Ajayi, 2011). However, none had studied the connection between institutional factors, parents' socio-economic status, social network factors and parents' choice of a particular SHS for their children within the Ghanaian cultural context. This study will fill this research gap by examining the major factors that influence parents' choice of SHS for their children. The study will further examine the relationship between the factors and parents' choice of SHSs.



## **Statement of the Problem**

Since the start of the Computer School Selection Placement System (CSSPS), there have been a lot of reported challenges confronting the system. According to Ajayi (2011), the CSSPS limits parents in their choice of schools since they have only six schools to choose from. Ajayi further posits that parents do not get the chance to see the final results of their children before selecting a particular school for them. He added that parents consider a range of factors in making a school choice for their children, however, the CSSPS lays much emphasis on the academic performance of the students which may not be one of the factors a parent considers in selecting a particular school. Therefore, the current system defeats the very reasons parents consider in making their choice of a particular school.

The idea behind school choice in the current study is simple: producers of secondary education can rely on the liberal market forces (ie. the real prevailing factors, other than the academic performance that parents consider when choosing a SHS for their children) to create a competitive environment (Coulson, 2005). Parents as consumers or buyers of education services want the best for their children and know what is in their best interests, perhaps more so than schools do (Oketch & Ngware, 2010). These challenges provided a platform for the researcher to find out some of the factors that parents considers most in choosing a particular SHS. This will help in recommending to policy makers to enhance the CSSPS and its criteria in placing students. In other words, the study examines

some of the factors that influence parents in the Cape Coast Metropolis in their choice of a particular SHS for their children.

### **Purpose of the Study**

The purpose of the study was to identify the pertinent factors affecting parents' choice of SHS in Ghana. Some parents choose SHS based primarily on academic reasons - test scores, class size, and curriculum offerings, whereas others choose schools more for the non-academic indicators such as proximity or conducive and attractive learning environments (Dahari & Ya, 2011). The specific objectives of the study were to:

1. Find out the factors that influence parents' choice of a particular SHS for their children.
2. Identify the type of SHS parents in the Cape Coast Metropolis choose for their children.
3. Examine some of the school institutional factors that parents look for in deciding the choice of a particular SHS for their children.
4. Ascertain how positively or negatively parents perceive the schools institutional factors, their socio-economic status and social network factors when choosing an SHS for their children.
5. Determine the relationships that exist among schools' institutional factors, parent's socio-economic status, and social network factors to parents' choice of a particular SHS.

## **Research Questions**

The following research questions and hypotheses were used to guide the study in examining the factors that influence parents' choice of SHS for their children.

1. What factors influence parents' choice of a particular SHS for their children?
2. Which type of SHS do parents in the Cape Coast Metropolis choose for their children?
3. What are some of the school institutional factors that parents look for in deciding the choice of a particular SHS for their children?
4. How positively or negatively do parents perceive the schools institutional factors, their socio-economic and social factors when choosing a SHS for their children?

## **Research Hypotheses**

### Hypothesis One

H<sub>0</sub>: There is no significant relationship between parents' choice of a particular SHS and schools institutional factors.

H<sub>1</sub>: There is significant relationship between parents' choice of a particular SHS and schools institutional factors.

### Hypothesis Two

H<sub>0</sub>: There is no significant relationship between parents' choice of a particular SHS and their socio-economic status.

H<sub>1</sub>: There is significant relationship between parents' choice of a particular SHS and their socio-economic status.

### Hypothesis Three

H<sub>0</sub>: There is no significant relationship between parents' choice of a particular SHS and their social factors.

H<sub>1</sub>: There is significant relationship between parents' choice of a particular SHS and their social network factors.

### **Significance of the Study**

This study examines factors that influence parents' decision to choose a particular SHS. The findings and recommendations of this study will therefore be of paramount interest to the management of the various senior high schools in the country since they might use this information to become more competitive by improving customer service, communicating with the community, and by improving and maintaining some of their institutional factors (Moranto, Milliman, Hess & Gresham, 2001).

In essence, this study isolates those qualities that parents seek and desire in their children's schools. This information will be of interest to all educators, government, heads of SHS, and other stakeholders. The study will also contribute to the field of school choice research by eliciting reasons for choosing or not choosing a particular SHS in Ghana, comparing the results with prior findings which were not based on institutional, parents' socio-economic status and social network factors. The results of this study will also be of use to authorities and policy makers involved in the CSSPS since they can consider some of the factors parents consider in choosing a particular SHS for their children, so that they can

consider these issues in their placement process instead focusing much on the examination scores.

### **Delimitation of the Study**

A single study cannot cover the entire spectrum of school choice as a problem. Hence, it is prudent to concentrate only an aspect of it. This is why the factors influencing parents' choice of a particular SHS for their children in the Cape Coast Metropolis has been chosen. The problem of school choice is a global one. No day passes without media reports of parents making unexpected and uninformed choices with regard to SHS for their children (Akpakli & Abbey, 2012). Most of these challenges when tackled as expected will help authorities and policy makers of the CSSPS to consider some of the factors that parents consider in choosing a particular SHS.

The study therefore, should have ideally assumed a national dimension or even covered a wider scope. However, it was delimited to parents in the Cape Coast Metropolis since most of these parents have raised concern regarding their school choice for the children in the metropolis (Opare, 1998), and them not getting chance for their children due to the strong competition that prevails in senior high schools within the metropolis. The study will further be delimited to the schools institutional factors and parents socio-economic status and social network factors that influence them in choosing a particular SHS, its relationship with other factors and the implications of the findings to government, heads of SHS, parents and other stakeholders in the Cape Coast Metropolis.

### **Limitations of the Study**

Quite apart from the help the present study can give to practitioners and researchers in relation to the understanding of the concept; it has several limitations which include the generalisability, subject and situational characteristics. The sample of the study was limited to parents in the Cape Coast Metropolis. The result may have restricted generalisability to parents outside the selected schools and area. The degree to which the results were representative of the population again could reduce the validity of the conclusions drawn from the results of the questionnaire as they apply to the entire population. Also, parents in the Cape Coast Metropolis are further up with answering questionnaires or even participating in a research (Opare, 1998). This may have negative effect on the answers given by the parents with regard to their objectivity and truthfulness.

It was assumed that the selected parents in the metropolis had sufficient knowledge and understanding of the issues the research was based on, and were in a better position to answer the items in the instrument accurately and truthfully, but this was not verified. The findings and conclusions of the study may not be projected for the future since issues related to school choice keep changing with time.

### **Organisation of the Rest of the Study**

This deals with the organisation of remaining chapters and what went into building up each chapter of the research. The rest of the study was put into four chapters. The second chapter gave the various authorities the researcher consulted in reviewing the literature covering the various components of the study. the

chapter also locates existing studies incorporating parents' choice of school. It covered the following sub-topics: school choice, parental choice, options in school choice in Ghana, the growth of public and private education in Ghana, factors considered by parents when choosing an SHS, and parents' socio-demographic background. Other sub-topics considered were empirical studies on parental choice in education, understanding school choice in a developing country and context and conceptual framework of the study.

Chapter three dealt with the methodology of the study. it covers how data were going to be sourced to prove the validity and reliability of the problem. Areas discussed were the research design, population, sample and sampling procedure, instruments, pre-testing of the instrument, data collection procedure and data analysis. Chapter four analysed and discussed the data to see the relationships and differences that exist among the variables used in the research activity. The fifth chapter was the summary of the findings, conclusion and recommendations.

## **CHAPTER TWO**

### **REVIEW OF RELATED LITERATURE**

This chapter is devoted to a review of the literature that relate to the research. The focus of this review is on factors that influence school choice and some related concepts on school choice. Also reviewed are empirical studies that are of relevance to the current study. The review is categorised under the following sub-headings:

1. School Choice;
2. Parental Choice;
3. Theories of School Choice;
4. Options in School Choice in Ghana;
5. The Growth of Public and Private Education in Ghana;
6. Factors to Consider When Choosing a Senior High School;
7. Parents' Socio-Demographic Background;
8. Empirical Studies on Parental Choice in Education;
9. Understanding School Choice in a Developing Country Context; and
10. Conceptual Framework.

#### **School Choice**

School choice is a common sense idea and a process that gives all parents the power and freedom to choose their child's education, while encouraging



healthy competition among schools and other institutions to better serve students' needs and priorities (Dahari & Ya, 2011). It can also be seen as a public policy that allows a parent/guardian or student to choose a public or private and in some other jurisdictions district or charter school, regardless of residence and location. School choice gives parents the freedom to choose a school based on its quality and their child's needs.

The modern-day school choice movement aggressively captures and conveniently appeals to two powerful and dynamic forces in most developed countries' histories: capitalism and freedom. Most developed countries were founded on the belief that competition is healthy and robust for any industry and, more importantly, for the consumer (Harrison, 2005). The economies of these first world or developed countries are among the strongest in the world, these economies have emerged as such largely due to the invigorating consequences of competition. The market-based approach relies on choice and competition to increase incentives to perform, improve and change (Finn & Kanstoroom, 2005).

The Darwinian nature of the marketplace in the school choice system demands that schools produce what the parents want at a price they are willing to pay (Le Grand, 2003). Low performing SHSs would quickly develop into low enrolment schools and the financial consequences for these schools would be quite acute (Robenstine, 2000). In short, strong and ideal schools survive and weaker, more anaemic ones do not.

Public education has long enjoyed protection from the refreshing and challenging effects of competition, and many parents - not to mention taxpayers

with no children in the school system - quite simply have had a bellyful of this situation. Stated more clearly, the consumer wants each student to receive the most thorough and challenging education at the least possible cost to the taxpayer (Robenstine, 2000). Competition, although not a panacea, is considered a necessary component to any system of school improvement plan (Harrison, 2005).

However, the school choice movement believes that there is no 'one-size fits all' possibility to schooling, nor is there a universal 'best' school model (Hill, 2005). According to Hill, every year school choice both excites and enflames passions around the country. It is expressed in diverse ways that paint either a positive or negative picture (Harrison, 2005). Proponents of school choice believe that choice will account for improved school productivity and increase the opportunities for low-income families to access high-quality education (Hausman & Brown, 2002).

Mann (2002) believes that these market forces will 'squeeze' schools and compel them to either provide enhanced educational experiences, or simply go out of business. Moreover, school choice utterly revolutionises how education is delivered; transforming it from a system controlled by the government to one controlled by the consumer (McCluskey, 2005). In short, if schools are not able to deliver, the public will compel it to do so (Mann, 2002). According to Mann, there has never been a time in history of public education when parents have been so prepared to control the destiny of their child's education.

On average, parents who are able to involve themselves in the school choice process of their children have a tendency to be actively engaged in their

children's education; which is a positive development (Hausman & Goldring, 2002). In addition to this positive development of increased levels of parent's involvement in their children's education, research indicates that parent satisfaction increases when they have a chance to make a choice for their children with regard to the SHS they are to go (Howe et al., 2002). Moreover, it appears that parents who are able to exercise school choice options are more likely to be dedicated to improving the culture of the school (Lynn, 2001).

According to Lynn (2001), family involvement in education is correlated with student academic achievement and other profitable educational outcomes. Once parents have a vested interest in their school of choice, they develop an appetite for participating in, and influencing school decisions in a manner consistent with high academic achievement (Hausman & Goldring, 2000). These parents once engaged in this process of school choice, continue in the role as advocates for their children, and also become supporters of the school (Harris-Brown, 2000).

Parents' selection of a particular school from among multiple alternatives make them committed to the chosen school and are more passionate about the school. When parents actively choose a specific approach to learning, both the particular school and the individual student have improved their chances for academic success (Hausman & Goldring, 2000). Active parental involvement is linked with positive school outcomes such as improved student morale, attitudes and academic achievement (Finn, 2001). The closer the parent is to the education

of the child the greater the impact on the child's development and educational achievement (Kasting, 2005).

Parents' involvement at the SHS is the simplest and cost-effective way to drive the school improvement process (Hausman & Goldring, 2000). On the surface, at least, it would appear that many parents, as consumers of education, are enjoying the increased opportunities to choose their children's schools (Patterson, 2001). As consumers, parents have many more choices and seem more likely than ever to demand similar chances to contribute to their child's education (Anemone, 2008).

According to Hill (2005), for school choice programs to be effective, parents must be able to choose between schools that are distinctive, coherent and reliable. Distinctive schools differ from others in a meaningful way and offer parents tangible alternatives to other schools. Coherent schools are defined by Hill as having shared values and goals. Reliable schools are extremely consistent over a great period of time. For most SHSs fervent supporters, the choice element present in these schools is what makes them shine academically with the students, and socially with the parents and stakeholders in the community at large (Hunter, 2005).

Hunter (2005) maintains that if parents are able to select schools, they would avoid the worst schools and select the schools that best match the child's individual needs. Parents will select the best schools for their children out of their own self-interest; schools will be motivated by the very same rationale. With regard to most private SHS, the larger the number of students in the school the

bigger they maximise. This notion compelled schools to differentiate themselves, in a positive way, from their competitors (Snell, 2006).

In addition to changing how education is delivered to children, parents' having the chance and opportunity to choose a particular SHS for their children contributes significantly in transforming the role of parents' in our modern society. This transformation turns parents from passive observers to mere participants to society's development. With the concept of choice present, it can be assumed that parents are happy with their chosen school since the choice was made voluntarily (Robenstine, 2000).

However, opponents of the school choice movement, suppose that school choice plans will further stratify our society along class-lines (Hill, 2005), or set in opposition different schools from the same school district (Howe, Eisenhart & Betebenner, 2002). But, for example with neighbourhood schools, or community schools as previously advocated for in Ghana, the ingredient of choice is simply not present. As a result there will be no way of empirically studying which schools are meeting the wants and needs of the community (Robenstine, 2000). Without the opportunity for parents to remove children from the public schools, parents must suffer twice; one, having to keep their children in a facility they believe to be unproductive, or being required to pay for an, often expensive, extra classes in addition to paying their school fees and neighbourhood or community school taxes. School choice theorists value individual choice more so than governmental 'expert' decision-making (Walberg, 2003).

School choice advocates have made it very clear that they believe excessive government control over the industry stifles both competition and innovation (Robenstine, 2000). According to Robenstine, international SHSs and other private SHSs who are under extreme competitive duress more often than not turn a profit, avoid losses and develop positive public relations. Such schools perform far more efficiently than their public counterparts, who are under no similar stress to turn a profit, avoid losses or improve their public relations image. The reasoning is quite simple; without any competition, the public SHSs are able to perform more wastefully and inefficiently when compared to the private sector (Henninger, 2005).

According to Henninger (2005), trying to make governmental schools as efficient as private ones is as hopeless as teaching cats to bark and dogs to meow. The school choice movement hopes to promote their position as a way to upgrade the public education system into a more effective education establishment (Hill, 2005). Decentralised decision-making is the most logical solution because at the end of the day, both the school and the parents will have their own best interests at heart (Harrison, 2005). If parents are determined to only select the best school for their child, and if schools are determined that they have to be the best to 'draw' students in; then school choice will have proven itself to be a self-fulfilling prophecy as well as a 'win-win' situation (Anemone, 2008). Schools that offer parents what they want (quality education) at a price they are willing to pay will attract students and thrive, while schools that cannot will pay the ultimate price and cease to exist (McCluskey, 2005).

## **Parental Choice**

Within the determination of government to provide education for all, also lies choice provisions, enabling parents to become - and stay - more involved in their children's education. Researchers have long been interested in what draws parents to a particular school and/or pushes them away from another school (Hill, 2005). The various factors can be lumped together into assorted categories, including academic factors as well as non-academic factors.

According to Bell (2007), the primary factors include the location of the school and the overall academic and social perception of the school. Other researchers such as Howell (2006) and Levine-Rasky (2007) have also suggested that the perception of the school drives the parental choice process. Contemporary parental choice studies are not limited to wealthy families. Recent research has indicated that low and middle income families choose schools for the same reasons and through the same mechanism - school visits, meetings with teachers and administrators, print materials, and by word of mouth - as do their wealthier counterparts (Viaden, 2007).

Viaden (2007) has written extensively about the primary and secondary reasons parents' choose specific schools. Her research reveals that approximately half (49.5%) of the respondents choose schools for their overall academic quality, nineteen percent choose schools because of their specific thematic focus or better still their visions or philosophy of the schools, and eleven percent choose schools primarily for their location. Moreover, once students are enrolled in their school

of choice, the empowerment and choice provisions of their parents' continue to exert their forces.

Howell (2006) suggests that parents that have students enrolled in 'underperforming schools' are more likely to request a transfer than parents who have a student in a 'higher performing school'. In fact, in his research he found out that the former group requests a transfer approximately 25 percent of the time, compared with the latter group which does so at a 10 percent rate. There have been many studies on school choice internationally and it will be appropriate to look at an overview of the various options in school choice within the Ghanaian cultural context.

### **Theories of School Choice**

The current study reviewed briefly some of the theories that underpinned the study. These theories focused on school choice. The theories considered are accidental theories, impulse theories and talent theories. With regard to accidental theories, it is widely stated by many people that individuals choose schools accidentally (Adeyinka, 2001). This suggests that the individual student or their parents' choice of a particular school is determined by an unplanned exposure to a powerful stimulus. For example if a group of parents are asked why they chose a particular school for their children, some would say that they just found out there was a vacancy in the school.

Impulse theories on the other hand are comprehensive theories of school choice which provides for an analysis of internal factors and elements of the school which help to condition the response to external factors. This means that



the parents' interest in a particular school may be by their impulse. These impulses will influence them to go to that school to secure vacancy for their children. Parents' choice of the school will be based on the external factors of school since these factors are the first to be noticed by all concern parents. External factors normally considered are school buildings, school environments and school location. However, the choice made by parents will become permanent when their expectation of the school internal factors such as quality teaching, parental involvement and students discipline support the external factors. This approach has been stressed by those psychologists who are convinced of the central and dominating importance of unconscious motivation in everyday life (Oladele, 2004).

The last group of theories considered was the talent matching theories. Individuals have different strength and weaknesses. This is why those who are concerned with vocational guidance should focus or pay attention to the assets of a particular individual in order to match the assets against the requirement of a particular school, either technical or non-technical school. This approach appears to have been the cornerstone underlying the vocational guidance movement in the country. Ginzbering, Axeldred and Herma (2011) emphasised that effective school choice based on vocation guidance is based upon the ability of the individuals to understand his or her own values and goals. Parents' choice of a particular school for their children can be seen as a development process which typically takes place over a period of time. The process is largely irreversible. It

ends in a compromise between interest and the opportunities which are available (Pietrofesa & Splete, 2012).

### **Options in School Choice in Ghana**

In Ghana, there are two major options in school choice: the public sector and the private sector. Within the public school sector, options include model schools, single sex schools, coeducation, specialised alternative schools, vocational and technical schools (MoE, 2009). The educational system in Ghana allows parents' to choose almost any SHS of their choice provided they are qualified and can afford to absorb the necessary cost involved. They may choose a private school or public school in any district or region of their choice (Bagley, Woods & Woods, 2001). Most of the public SHSs in Ghana such as Mfantipim, St. Augustine's, Wesley Girls and T. I. Ahamadiya SHSs, are public funded schools to some extent, but are supervised by religious groups under a contract that exempts them from some state or local regulations completely. This system within the public sector education in Ghana tends to provide more choice options to parents (Ball, 2003).

According to Brantlinger (2003) and Gorard, Taylor and Fitz (2003), within the private sector, parents and students can choose a private school or select the international schooling route that pleases them. Ultimately, parents are the major decision makers in the choice of which school is best for their children (Merrifield, 2008). As parents become more influential actors within the educational system, the recognition of parental attitudes, beliefs, perceptions, and their influences will become increasingly important to the educational community

(Gorard & Fitz, 2006). Parents are free to take their children where they feel the best education is available based on their family's values and ideologies (Stevens, 2001).

### **The Growth of Public and Private Education in Ghana**

Before Ghana's independence in 1957, secondary education was mainly provided by the church but with regulation from the state. The state provision of secondary education was scaled up six years before independence following the implementation of accelerated development plan for education (ADEP) in 1951. After independence, Ghana's education policy was driven by a socialist agenda and primary and elementary educations were made free whilst for secondary education only those in the northern part of Ghana were fee and feeding free (McWilliam & Kwamena-Poh, 1975). However, the liberalisation of the Ghanaian economy in the late 1980s coupled with the 1992 constitutional provision that gave individuals the right to establish and maintain private schools (MoE/GES, 2001) contributed to the growth of private schools and provided choice to those that could afford the cost of private secondary education.

### **Factors to Consider When Choosing a Senior High School**

Parent's decision processes consist of evaluating their children's needs and their capabilities, gathering or searching for information and evaluating all the available alternatives (McDaniel, Lamb & Hair, 2006). What happens to a child's teen life has a profound impact on the child's later achievements in life. Teenagers who enter the next level of education or the world of work and are not yet ready to learn or not equipped to handle the new circumstances they find

themselves, will continue to have difficulties later in life if no intervention is taken (Gorard et al., 2003).

Arguably, parents' need for skill and strategy when choosing schools is becoming ever more important in today's society where there is a growing emphasis on academic and professional credentials. According to Ball and Vincent (as cited in Ball & Vincent, 2008), young people today are 'increasingly forced to chase credentials in order to secure a chance of successful entry into the world of work, and so schools are an important investment' (p. 13). Ball and Vincent went ahead to make a statement to the effect that the declining faith in the ability of employing organizations to offer secure long-term employment, or to meet their high hopes for career advancement, will lead to an increasing dependence on academic and professional credentials as an insurance policy in the same way that people insure themselves and their home against any eventualities. That this trend reflects the anxiety among parents concerning the secondary and tertiary education of their children.

Power (2001) argues that unlike the very few wealthy and powerful individuals whose assets are such that privilege can be passed down irrespective of external accreditation, members of the middle class as well as the poor in the society, largely depend upon the credentials bestowed by the education system in order to acquire or hold on to their position. However, there are various factors that may limit or enhance a parent's choice when deciding on a particular SHS. Identifying these factors will enable parents to make optimal choice and fulfil their needs and that of their children (Hawkins et al., 2007).

As customers of SHS, what do parents consider when choosing SHSs for their children? According to Reay and Lucey, (2003) parents, especially educated mothers will do anything including drawing on their social and cultural advantages as well as information and time, to select the best schools for their children. Private and SHS treat education as business and as a good quality product; it always comes with a price. Consumers perceive that, higher price or fees indicate better quality (Dahari & Ya, 2011). According to Akaguri (2011) low income households have very little or no choice at all since school choice is clearly dependant on the ability to meet the cost. Stated differently, the most influencing factor that comes to play when parents are selecting a type of SHS for their children is the affordability of the fees and that this is particularly so for low income households.

Parents who send their children to expensive private SHS and even some expensive public SHS sometimes want to maintain their social class (Lucey & Reay, 2002), as parents want their children to be in the group of children who are of equal status and regularly socialise with them. But, some rich parents will purposely send their children to expensive, private SHSs because they can afford and see the association or belief of what money can give the qualities and benefits these expensive private institutions can give (McDaniel et al., 2006).

The ability of the school to meet the child's individual needs and the school's high expectations and standards of education is the reason most frequently given by parents for choosing private SHSs rather than fully funded government SHSs (Dahari & Ya, 2011).

A school which maintains well organised quality and attractive programs usually appear attractive to parents. Parents expect school programs to be an instrument to shape and prepare the child for the expected challenges that await him or her in the society. The programs of the school must transform the child into a responsible and competent member of his or her society (Yarquah, Baafi-Frimpong & Atta, 2011). At quality SHSs, there is a proper development of physical, mind, creativity and moral values of students. High quality SHS programs require well-trained teachers with a bachelor's degree or a post-graduate degree in second cycle education (Ball & Vincent, 2008).

Hoxby (2003) believes that a teacher's qualification adds up to his or her quality and this is a powerful and consistent predictor of student achievement. Also, modern infrastructure and facilities inside and outside the building, good relations between teacher and students, and schools regularly keeping parents informed about how students are performing academically create an atmosphere for quality that parents can easily buy into.

According to Reay (2004) private SHSs maintain qualified teachers, good facilities for extra-curriculum activities and invest on advertisements to be noticed by prospective parents as their customers. With, regard to qualified teachers, parents in seeking information to make a choice ask for information on the level of teacher's qualification and how many certified teachers or teachers with bachelor degrees and training in respective speciality are there per child? At least half of the staff in any SHS must be qualified (MoE, 2009). Parents can also ask

about the experience of the teaching assistants. Often, uncertified yet experienced assistants can be marvellous teachers.

A school that establishes a harmonious interpersonal relationship between students and teachers may not go unnoticed by potential customers. When parents visit a school they intend to select for their children, they observe how the teachers interact with the students. Do they approach the students with warmth and care and appear happy while doing their job? Do the teachers sit next to the students and work together with them, or do they supervise the students from a far? Once again, parents must consider their children's needs. Some students respond best to teachers that exhibit a lot of physical warmth, for example hugging. It is important that teaching and support staff establishes harmonious and interpersonal relationship with students and treated them like family members (Noden, 2000). Parents sometimes send their children to the same SHS as their elder children or they themselves used to attend, because of the satisfaction and image the school brought to them (Dahari & Ya, 2011).

Kleitz, Weiher, Tedin and Matland (2008) indicates that parents who choose schools often cited academic performance judged in terms of the number of students that pass a standardised test scores as their main priority. Other studies have also shown that households that placed priority on academic achievement were more likely to choose private schools because of their better performance in examinations and test scores (Kingdon, 2006). Tooley (2009) adds that households choosing private schooling often cite better performance of private schools in test scores and examinations. In addition, Dahari and Ya (2011) also

posit that emphasis on an excellent academic record is another factor parents consider when choosing a particular SHS for their children. For instance parents would prefer SHSs that have good academic record with regard to the performance of their students in external exams such as the West African Examination Council (WAEC).

According to Jackson and Bisset, (2005) for majority of parents who opt for single-sex education(whether public or private) for their children, the fact that the school is a single-sex is not an important factor in their decision-making process, but that parents have the very impression that single-sex schools tend to do slightly better academically than co-educational schools. In other words, parents who consider excellent academic record of a school as the main influencing factor in their school choice may most likely select a single-sex educational type of school for their children.

Parents' emphasis on other factors rather than upon whether the school is single-sex or mixed has also been found in other research. Robinson and Smithers' (2009) asked university students to think ahead to the type of education (single-sex or co-education) that they would want for their children. Robinson and Smithers suggested that for many of their respondents what mattered most to them was not whether the school was mixed or single-sex but whether the school was a good one which had qualified teachers and the teachers were committed to the school and whether the school will suits the child's needs .

Some SHSs require a certain amount of parental involvement, while other schools prefer that parents 'sit on the side-lines' unless needed. Parents, who



know the effect and the importance of their involvement in their children's educational experiences, will choose a SHS that welcomes parents' involvement (Prior & Gerard, 2007). Most established SHS, whether private or public, would make extra effort to reach out to parents and develop partnerships with them. An example can be made of the Parents Teacher Associations found in almost all schools in Ghana whether public or private. If parents do not have time in their schedule to participate in school activities, they will make sure this kind of participation will not be required (Dahari & Ya, 2011).

The approach to maintaining high standards of discipline in a school is very much considered by many parents. Some SHSs encourage independence, while others emphasise discipline and order. Parents would check if the school has a strict daily schedule and if all students must participate in each activity or if the teachers change the school routine according to the needs and desires of the students. With the emergence of Christian and Islamic civilization in Ghana, most parents would like to have the foundation of religious values and discipline for their children. Therefore, they would prefer a SHS with such capabilities. In other words, parents who are looking for good moral, religious values and discipline in their children, will look for SHSs that are associated with the training and development of such values and characters. This aspect of SHS is reckoned as one of the most important aspects of family life and is primarily the responsibility of parents (Dahari & Ya, 2011).

Osler & Vincent (2003) also suggest that strict disciplinary practices in some schools have well-established historical roots, and the strict codes of

behavioural conduct that are seen to characterize some public schools and many private schools are attractive to both parents of boys and girls alike. In the same vein Echols and Willms (2005) found out in their study that parents of to be first year SHS students' were more concerned with school disciplinary climate as well as school popularity and reputation than parents of final year SHS students.

Religious Orientation is another factor that some parents will hardly gross over. Some parents feel that teaching students' religion is reckoned as one of the most important aspects of family life and is primarily the responsibility of parents. With the emergence of Christian and Islamic civilisation, majority of Christian and Muslim parents would like to have the foundation of Christian or Islamic knowledge for their children. Therefore, they would prefer to send their children to SHSs with such religious values. For Muslim parents who are looking for good moral and religious values in their children, they will look for SHSs that are associated with the Islamic religion (Sardar, 2008).

Sardar (2008) also stressed that knowledge is one of the most fundamental and powerful concepts of religion, and the absolute source of knowledge and the judge of validity is the Qur'an for Muslims and the Bible for Christians. According to Waddy (2005) teaching religion to students is most effective in story form: tales of brave and generous men and women who did great things for their fellow men, or about rich and poor people who are unequal in possessions and yet are equal before God.

Facilities for extra-curriculum activities is sometimes the next thing parents consider after the academic potentials of the school, with the intentions of

developing a complete individual. Parents will observe how the school is organised, such as specific areas for different forms of play or games, sometimes referred to as activity centres. These areas usually include arts and crafts, football and hockey pitch, basket and volley ball courts and activities for students to work on individually or in small groups. This tradition of many schools to keep a balance between academic and sports is particularly appealing to many parents (Ball & Vincent, 2001).

The cleanliness and hygienic conditions of the school is another important factor that parents look for when choosing a SHS for their children. Parents will usually be bordered if equipment and building areas or surroundings are clean and hygienic? Hygiene and cleanliness are especially important to ensure student's health and safety. Dirty classrooms, bathrooms and compounds can course skin diseases and cases of worms' infections to students. With frequent cases of food poisoning such as cholera at schools because of unhygienic food preparations, dirty eating areas and utensils, parents would check the cleanliness of SHS, especially those that are boarding, before registering their children (Dahari & Ya, 2011).

Small class size is becoming more vital to quality education as students prefer more space to move and rest. Most private and international SHS will provide places between 12 to 24 children and there should be no more than 26 children in one room (Jackson & Bisset, 2005) . In their work, Jackson & Bisset made the point that there should be a limit on the number of students per class and the number of students per teacher. That one can be sure that parents, especially

the educated ones would observe how many students are there in the classroom?  
Or what the students-teacher ratio looks like?

Sometimes, parents' need for convenience will require that they consider location of the school as the major factor in choosing a school for their children. Parents who consider proximity of school to the home for convenience sake usually opt for day schools (Bisschoff & Koebe, 2005). Furthermore, household choice of private secondary schooling may be influenced by the safety and convenience of schools to their children. Where the location of a school is far away from a child's home or where the school is considered by a household to be unsafe for children, they are more likely to enrol in the nearest and safe school even if such a choice would imposed heavy cost burden on the household (Tooley, 2009).

In China, Tooley (2009) indicated that households in remote areas prefer to enrol their children in private schools because of the distance and danger of travelling to the nearest public school. In Ghana, the absence of secondary schools in some communities constitutes a barrier to access to secondary education (Chao & Alper, 1998). Consequently, households would have no option but to enrol their children in the only available fee paying private secondary school in their communities (Akaguri, 2011).

According to Sa, Florax and Rietveld (2003), accessibility in terms geographical location of a type of secondary educational institution is the main factor that parents would pay particular attention to in the educational transition process of their children. After controlling for the student's parent's socio-

economic background, SA Et Al. (2003) concluded that individuals who live in closer proximity to a high school education institution are more likely to continue studying after junior high school, and they are more likely to choose that type of institution which is in close proximity to them.

Interestingly, Bell (2009) suggests that senior high boarding schools have become more competitive as schools attempt to attract parents to send their children to these schools and retain already existing students. Bell believes that the closeness of a school to parents' residence or home is possibly less influential in parental choice of a school, as the boarding school has a far greater role to play in the child's overall development and wellbeing due to the time spent at the school. So for Bell, the fact that the school is boarding is paramount to parents regardless of its location. Bell however, admits that where the school choice set of parents is limited as in the case of only day-schools available to parents to choose from, then proximity of the school to parents' residence would be the overriding factor influencing school choice of parents.

Palmer (2005) observes that many players in the secondary school education market uses boarding institutions and its facilities as a way of positioning themselves to attract would be customers (i.e., parents exercising their school choice options). That these players in the secondary school education market understand that many parents believe that education takes on a broader meaning at boarding schools and that boarding schools often have an explicit mission to not only educate students in the classroom, but to also help them

become better-rounded individuals and often do very well at educating students academically (in ways that may be better than day schools).

Furthermore, Boarding school alumni are generally very enthusiastic and proud of their boarding school alma maters (in many cases, more so than day college alma maters). The traditions and history behind many boarding schools drive the character of each school, and influence each student who goes there. The shared experience of this tradition and history creates a strong network of people and a feeling of community that lasts for life and many parents would want their children to be part of a proud community or have such experience and so will choose the same boarding school they attended or a boarding school for that matter for their children (Vigar-Ellis, 2013).

In addition support services like counselling, health and social services offered in boarding schools are adequate and taken more seriously than in day schools. These service units at boarding schools are generally well-staffed and taken quite seriously. Counsellors often have plenty of experience in helping student applicants identify appropriate programmes that suites their personality, abilities and goals of who they want to be come in future. Also Academics at boarding schools operate at high standards. The environments are usually very conducive and attractive for learning. Students are pushed to "ask why," become inquisitive, and tackle challenging problems. Teachers are usually highly qualified and are committed to the school. Course selections at boarding schools tend to be quality, attractive and quite diverse (Parker et al., 2007).

Dale and Krueger (2002) in their research on the topic: Estimating the Payoff to Attending a More Selective College, seems to suggest that parents who find their children in low performing elementary schools or better still, parents whose children were academically poor or performing below average during their elementary school days, usually apply to less selective public or private day senior high schools. Dale and Krueger however, also admitted that some parents irrespective of the level of academic performance of their children at the elementary school level select some of the top public or private single-sex boarding schools for their children. That this is because many parents believe attending a more selective or top school may improve academic outcomes for their children as 'high-achieving students' and that could improve the socio-economic status of the children and them, the parents in the long run.

In other words, according to Dale and Krueger, some parents to some extent or to a large extent or to a very large extent consider the academic performance of their children prior to entering senior high school, when choosing a particular type of senior high school for their children. Conversely, some parents to no extent are influenced by or consider the academic performance of their children prior to entering senior high school, when choosing a particular type of senior high school for their children.

Any school that wants to succeed will create an identity that parents and other members of the society will recognise and buy into. In order to achieve that, schools need a clear and coherent brand (marketing techniques or strategies) to make them more marketable, attractive and known in the eyes of parents' and the

society at large. Schools can use these branding techniques in a positive way, to produce a positive outcome (Schroeder & Salzer-Moerling, 2006). Therefore, Kingdon (2006) was right to have suggested that the design or the redesign and colour of even a school's uniform can harmonise the school's vision and message and help present the school to parents or the general public in an attractive way. Now believe it or not I know some parents who chose a particular senior high school (Adisadel college) for their children because they "just love" the colour (black and white) of the school's uniform.

### **Parents' Socio-Demographic Background**

Recent research indicates that the context of parental decision-making with regard to school choice is far more complex than parents just buying into institutions high academic records, excellent programmes or result of parents' rational calculations of the economic return of their investment in any particular educational options. There are many unobserved factors that are usually difficult to measure. These factors account for differences among families that select private, public, and alternative schools, and might also account for differences in student achievement scores (Greene, 2001).

Stated more clearly, parental school choice is part of a social process influenced by salient properties of social class or socio-economic background of parents and their social and professional networks of relationships (Bosetti, 2001; Ball, 2003). Parents, whose network does not provide relevant influences and access to relevant and valuable information regarding options of school choice, are limited in their capacity to make informed choices (Smrekar & Goldring,



1999). Parents' socio-economic status includes the level of education of parents, particularly mothers since they are the key decision makers, level of family income and the family's values and beliefs about the goals and purpose of schooling (Ball, 2003). The parents social networks may include knowing some influential people in the school who could help get admission for their children, knowing some influential people who attended that school or as an old boy or girl of the school (Bosetti, 2001).

According to Dustmann, (2004) illiterate parents lack the motivation or have little or no knowledge and time to think through and know which school their children should attend. But desiring what is good or best for their children, illiterate parents may rely on the suggestions from educated friends or choose those schools they see their neighbours children attend. Dustmann also found out that educated parents on the other hand show more interest in their children education and may even choose the same school they attended for their children. Eduwed (2005) opined that it is only realistic that uneducated parents desire help from friends and neighbours in order to make satisfying choice of school for their children.

Jenkins and Schlueter (2002) also believe that parents' socio-economic background is an important factor that determines parents' choice of SHSs for their children and that rising cost of education and services may force parents to settle for an affordable SHS rather than one that they would prefer. In Ghana, government run SHS are cheaper than private SHSs. For example, Komenda Senior Secondary Technical School, which is one of the public SHSs in the

Central Region only charge approximately GH¢ 300.00 per the academic year for each student. While private SHSs normally charged more than GH¢ 300.00 per student, this, is hard for low income earner parents especially to those who have more than one child in the family.

Parents' educational level also determines the choice they make for their children's education. Educated parents tend to be involved in their children education at SHS level and even at tertiary level. They will look for a prestigious school with the entire needed component which includes classroom practices and environment that promote student's total growth and learning (Ceglowski, 2007). More so, college or university graduate parents will search for quality SHS and set the extra expenses in their budget for these purpose (Dahari & Ya, 2011).

Household income or assets which are normally proxy for household resources are also positively related to educational choice (Shneider, Schiller & Coleman, 1996) and that higher income raises the household's capacity to afford the cost of private education. In the US, studies have shown that higher income households were more likely to enrol their children in private school compared with their low income households (Schneider et al., 1996) because of the superior quality education private schools provide.

Similarly, in developing countries, high and middle class households with their relatively high income enrol their children in expensive private schools. These are children mainly from better socio-economic background and therefore enter private school taking along their home advantage. However, in poor rural environment where majority of the households lack social and economic capital,

private schools might not be adding that value or making much progress in students' achievements (Oketch & Ngware, 2010). In rural areas of Ghana, households that are relatively better off including those that have social network of friends and relatives that provide them with resources for education may enrol in fee paying private schools.

Studies have shown that parental education, household income and occupation are positively related to school choice (Colclough, Al-Samarrai, Rose & Tembon, 2003; Goldring & Philips, 2008). Parents or household heads with higher educational attainment levels tend to place more value on education and this is reflected in their interests and attitude shown in education. Besides, the level of educational attainment enables parents to seek relevant information about schools and thus able to make more informed decisions on educational choice (Goldring & Philips, 2008).

Household or parents' socio-economic background factors like household income and the level of education of parents affects school choice and child participation in school. Individuals with low or no education can only receive low wages and therefore are likely to face challenges with regard to which type of school they can select for their children (Colclough, et al., 2003). Moreover, private costs of education in the midst of low income, as well as cultural and social norms impact on households' decision about whether or not to enrol a child and whether a boy or a girl should be sent to a private or a public school (Harma, 2008).

In an effort to further understand the motivation underlying parents' decisions, Echols and Willms (2005) found in their study that amongst parents who did not exercise choice, (this was an educational system where the grade level which your children got at the junior high school automatically determines which type of SHS to go) those with higher socio-economic status were more likely to have considered an alternative to the assigned school, and amongst parents who did choose, those with higher socio-economic status were more likely to consider more than one alternative. That although almost 75 percent of the respondents believed this parental action would have a negative effect on the schooling system, a significant number were prepared to choose a different school because it might increase the chances of success for their children. These parents felt their designated schools were not popular and prestigious enough and for that matter, did not fit the socio-economic circumstances of their children. Also, Echols and Willms found that parents who were highly educated were more likely to seek and value information obtained from teachers and headteachers, from school meetings, and through visits to the school before making their choice of school.

### **Empirical Studies on Parental Choice in Education**

A substantial challenge in reviewing and comparing studies on parental choice in education is that each study asks somewhat different questions, selects different factors of influence, select different research designs and the fact that these various researches are done within somewhat different school choice sets or school choice systems. This poses a problem of comparative analysis. For

example, if a study poses the question of choice in terms of what were major factors that influenced parental choice versus being asked to rank in order, a list of possible factors, even though the same factors may appear in both set of questions, they may be ranked differently (Mapasa, 2005).

The focus of this study is on the factors that influence parents' choice of a particular SHS for their children. Studies on parental choice in education go back at least 40 years and across nations. The review covers researches on parental school choice done in America, Europe and Africa including Ghana respectively.

Poll (1969) studied 2,000 parents who had chosen private schools for their children. Among Catholic parents, when asked the reasons for choosing private school, 72 percent cited religious orientation, 63 percent indicated good academic record as in diligence in study habits, and 61 percent indicated a desire for stricter discipline. Among Protestant parents, 93 percent indicated religious orientation as important, whereas 80 percent suggested values, attitude (which equally mean high discipline), and being closer to home. The results of this poll suggests that parents from religious backgrounds considered the religious environment of the school and training as most important in their decision to enrol their children in private schools with academic quality and proximity of school to home further down the list of priorities.

One of the earliest research studies on parental choice conducted in 1981 by Edward and Richardson was to determine why 1,927 students left the Montgomery County Public Schools in Maryland in order to enrol in private schools. Results showed that lack of discipline, overcrowding, nature of

curriculum content, lack of religious values, and problems of racial integration were primary reasons for leaving.

Erickson (1981) did a study on parental school choice that confirms that of Edward and Richardson. He asked 268 private school parents “why they preferred the private school as their preference” (p. 93). The primary reason was religion or spirituality, as indicated by 22.0 percent of the respondents. Quality and attractive academic programmes was mentioned by 20.5 percent of the respondents. Maintaining high discipline was chosen by 16.8 percent of the respondents.

One of the interesting aspects of this study was that a sample of public school parents were also asked why they preferred the public school for their children. Proximity or convenience was mentioned as the primary reason by 29.9 percent of the respondents. School fees affordability was the second reason for those who preferred public school, with 19.3 percent stating this. Academic quality as in excellent academic records and qualified teachers was cited by 15.5 percent of the respondents. Family tradition, as in parents or siblings attending the same school and someone in the family working in public schools was indicated by 13.6 percent of the respondents as the reason for choosing public schools.

In comparing the reasons behind the educational choice of public and private school among parents, Erickson (1981) held that those who chose private schools “were more sophisticated (in other words, they were educated), thoughtful, and concerned about their children’s learning than were the people

who simply followed the normal pattern of public school patronage giving the matter little thought” (p. 96).

More so, Peebles, Wilson, Wideman and Crawford (1982) sought to ascertain the reasons why 392 parents transferred their children from New York public schools to private schools. The study showed that 28 percent of all respondents wanted their children to have a Christian religious education, 26 percent were interested in higher academic standards or record and a more quality, attractive and challenging curriculum or programmes for their children, and 20 percent were looking for better or high discipline for their children.

Hunter (1991) targeted 289 parents who chose private schooling for their children. First, parents were asked to give their reasons, unprompted, and then were presented with a list of 26 possible factors covering school characteristics of the students, the teachers and management, and the curriculum. The parents’ main priorities were good standards of behaviour, academic results, discipline, and proximity to the school. When parents were asked to elaborate on the reasons for giving priority to the four most important factors, many explained that good discipline produced an orderly environment in which the children would be able to learn. Good academic results were seen by parents as the most important outcome of good schooling and as evidence that their children had received good education. Parental comments also indicated that many chose schools that appeared to offer similar experiences to their own traditional style of schooling.

Daugherty (1991) conducted a study of the relationship between enrolment changes and selected factors in private secondary schools in the San

Francisco Bay area of California. School choice was sensitive to cost of education, resulting in enrolment decline, indicating that parents' choice options were influenced by their financial constraints. Apart from cost, the most prevalent reasons parents consider in choosing a particular school were on the basis of qualify teachers and secure environment which invariably create conducive learning environment.

Goldring and Bauch (1993) focused on private school choice of 1,070 parents from New York State, mostly from low income groups. Parents ranked the 25 reasons for choosing a certain private school. Those 25 reasons were grouped into five categories: child's choice, location/family reasons, discipline, religion, and academic curriculum. Ninety-eight percent of all the parents rated discipline as "important", and 85 percent rated it as "very important". Goldring and Bauch concluded that "when society provides a wide range of school choice options, poor and minority parents have a better opportunity successfully to find a good fit between family and school, which should be the long-term aim of effective public policy" (p. 141).

Laudermilk (1994) interviewed parents from rural, suburban, and inner city in the Kansas City, Kansas, area about reasons for choosing public magnet schools, private schools, and home schooling. For those who chose private schooling, the findings suggested that parents were influenced most by (a) the expected academic challenge (in other words the school has high expectations for students), (b) the selected environment (i.e., conducive and attractive for learning), (c) the desire to escape undesirable situations, and (d) the



extracurricular opportunities. The findings were very similar among each of the three groups, suggesting that population density was not a factor as he thought.

However, the area of academic challenge and excellence, which was the first concern for parents who chose the magnet and private schools, was not one of the concerns for the parents who were home schooling their children. The home schoolers' major concern had to do with sharing and defining their personal values with their children and having parental autonomy.

Johnson (1996) surveyed 1,736 parents who enrolled a child in private school in San Diego County, California. Johnson identified several key areas of concern for parents. Those areas of concern included (a) the effectiveness of instruction (in other words, parents were concerned about the teachers qualification); (b) discipline; (c) school environment; and (d) parent involvement and values consistent with the home and school.

Taylor (1996) added a new twist to private school choice by asking parents with children already enrolled in private schools in Miami, Florida, how 14 different factors influenced them in their choice of their specific private school. The results suggested that parents look for a private school that would satisfy the individual needs of their children. They also desire a school compatible with their own values, morals, and philosophies. In addition, parents looked for a school that they felt offered academic quality, religious education, small class size, and proximity of the school to their place of residence.

Wolfe (2002) studied parental choice in Georgia, including urban, rural, and suburban areas. The study identified five major reasons why parents choose a

specific school and the findings, like that of Lauder milk (1994), were consistent in all three areas: urban, rural, and suburban. The top five reasons parents chose private schools in Georgia were (a) students' education, (b) small environment as in small class size, (c) safety, (d) parents attended the school, and (e) friends and family influenced the choice.

Parker et al. (2007) on the other hand found out in their study on the topic: "School Choice Attributes: Positioning a Private School" that extra-curricular activities, feelings of community (i.e., a harmonious relationship between the school and the parents or the families or homes of the students), teacher quality (which also meant qualified teachers), small classes and the price or affordability of the school's fees were the institutional factors parents considered in choosing a private secondary school for their children.

Internationally, the reasons for selecting schools match the results in the United States. In Europe, Munro-Hunter (2003) investigated how and why parents chose private schools for their children in Canada. The data suggested that parents chose their particular school based on religious considerations, academic quality (as in quality and attractive programmes), the school's environment being conducive for learning and individualised attention and the relationship between home and school. That is; the fact that the school regularly keeps parents informed about how their children are performing academically.

In Australia, Beavis (2006), the key factors identified behind parental choice were grouped into three categories: first, discipline, religious and/or moral values, the traditions of the school itself, and the requirement of school uniforms;

second, parental socio-economic status and the costs associated with secondary schooling; and third, the culture of academic excellence in the school.

In an explorative research study carried out in Britain, Jackson and Bisset, (2005) sought to explore factors influencing parents' choices of single-sex or co-educational schools in the independent sector (that is what is known in Ghana as private schools who are independent and for that matter do not receive any financial support from the government). The paper drew data from three of the private or independent schools at both their junior and senior secondary school levels: a boys' school, a girls' school and a co-educational school. Data was generated via questionnaires (225 responses) and semi-structured interviews (15 sets of parents). Parents were asked to rank in order of importance which of these factors; i.e. the School is prestigious, excellent academic results, quality teachers, Small class size, Care of the pupil, Discipline, Reputation of Head, Good facilities, Sports success, Accessibility, Fee level, Recommendation of friend, and Single-sex/co-education they consider most important when choosing a secondary school for their children.

In 2007, West, Varlaam and Mortimore carried out a study in inner London focusing on the attitudes of parents toward schools. A number of parents that were interviewed mentioned the following reasons: The school's closeness to home, good reputation, school's relation were in place, (in other words, there is a harmonious interpersonal relationship between students and teachers in the school), good discipline, single sex school and the school was a religious school.

In 2008, the Royal Borough of Kensington and Chelsea (as cited in Halstead, 2009) also observed parents' reasons for choosing their children's current or preferred school. Parents mentioned the following reasons: academic reasons, such as, range of subjects, examination results, the school has qualified teachers. Some were influenced by recommendations from friends or relatives, or because they already knew someone, or had an older child, at the school and had a favourable opinion of the school (child or relative preference). Discipline was highlighted as a reason for choosing church schools. Location and single sex were also other reasons that were stated.

In the Southwest of England, Webster, Owen and Crome (as cited in Halstead, 2009) examined parents' choice of secondary school and found that a sibling already attending the school was an important factor, which influenced their choice of secondary school. Proximity to home, academic achievements, facilities and atmosphere of the school were other reasons but these rated lower.

The findings suggested that the excellent academic record and prestige of schools are key features guiding parents' school choices and that these factors are particularly important amongst parents who opt for single-sex education for their daughter(s) or son(s). According to the researchers, the centrality of examination results of the school in the decision-making process is unsurprising given the dominance of standards discourses in education at the moment (pp.208). In this regard, their research findings are in line with others in this sphere (for example, Robinson & Smithers, 2009) which suggest that whether a school is single-sex or co-educational is less important than whether it is a 'good' school that is placed

favourably in the league tables. However, the researchers did admit that whether a school is single-sex or co-educational is an important factor for many parents. Furthermore, the long-held view that single-sex education has advantages (especially academic) for girls, whilst co-education has advantages (especially social) for boys, still prevails.

Sometimes even given different structures of families, the same strong association is made between high academic record and single –sex educational schools. In Jackson and Bisset’s (2005) research, it was found out that father only households and father with stepmothers households dared to say that if you want to send your child purely for an academic education, you send them to a single sex school even though co-educational schools are still very good because there is more of a social interaction (p. 203).

In the same research a mother only household, whilst clearly valuing the social side of co-educational schooling, chose a single-sex school for her sons. She, like many others in the researchers’ sample who chose single-sex schools, placed heavy emphasis upon the academic results and the prestige of the schools. Often, it was the academic reputation of the school rather than whether it was single-sex or coeducational that was the most important factor, as parents who had chosen single-sex schools told the researchers: ‘We chose the school not because it was single sex, but because it had the best exam results’ (pp. 203).

Similar findings are also found in studies about school choice and charter schools. Buckley and Schneider (2007) identified three primary factors

influencing parents in choosing a particular SHS: academic quality, as in quality and attractive programmes with qualified teachers, test scores and safety

In South Africa, Mapasa (2005) in his dissertation submitted to the Faculty of Communication and Educational Studies at the Port Elizabeth Technikon, did a case study of some selected (6 out of the 8 Model C schools in the township) schools in the Port Elizabeth townships on the topic: ‘An analysis of factors influencing the choice of particular schools in preference to township schools, in the Port Elizabeth area’. Model C type of school was a state-aided school run by a management committee and a principal. The management committee had the power to appoint teachers, decide on admissions policies, deal with curricular developments and impose fees. A set number of educators were paid by the state while the rest of the expenses had to be carried by the parents. In other words Model C schools are the same as public schools in Ghana. The focus of this research was to determine the reasons that prompted the parents of the students of those selected schools to prefer schools that were far from their homes while there were schools situated nearer to their homes.

To accomplish this, Mapasa did a review of literature on why students in other parts of the world moved from school to school and why their parents send them to particular schools. The literature assisted in identifying key issues pertaining to school choice. These issues were translated into questions used in questionnaires to parent mostly and some few students to determine the reasons for preference of schools outside the townships. The data gathered via the questionnaires led to interviews with the staff from the schools in the areas where

the case study participants live. Apart from gathering data for interpretation the interviews were also used to triangulate data collected via the two questionnaires.

The five most important factors that were common to the parents and the students, identified and endorsed by the educators as influencing school choice, were firstly the fact that high status socio-economic background parents prefer high status schools (i.e. schools that were popular and prestigious to attend). Secondly, safety, discipline and the smooth running of the school are of high importance. Thirdly it was indicated that extra- curriculum activities in the school curriculum play an important role. The opportunity the school provides for parental involvement was rated as the fourth most important factor. The teachers' commitment toward work and the school were rated as the fifth most important factor. The research report finally made suggestions by way of recommendations of possible factors that had to be taken into consideration when determining strategies to attract parents to send their children to township schools.

In a very recent research on parental choice conducted in South Africa by Vigar-Ellis (2013), the researcher sought to bring to bear the understanding of the choice criteria of parents. A sample of 169 parents and old boys was chosen using the database of a particular boys' boarding school in KwaZulu-Natal (KZN), South Africa, and sent questionnaires. Quantitative analysis was conducted to determine the most important criteria. The top two criteria were found to be a safe environment as in an environment free of drugs, alcohol, conducive and attractive for learning with clean and hygienic condition.

The second criteria or factor was competent staff or qualified teachers. According to the researcher as a boarding school is a home away from home, this environment is a critical factor for parents making a choice of a boarding school. Parents want to know that their children will not be exposed to, or have access to alcohol and drugs, that they will not come to harm, and that the school will do whatever possible to protect their boys from social problems such as underage drinking, drug abuse and pornography. The next two most important factors were to do with the competence and qualifications of those looking after these young men: the teachers and the school management. These people are responsible for ensuring the safe environment and are the guardians of these young men during their years at the school. They therefore play a critical role not only in the education of the boys but in their overall upbringing.

The fourth and fifth most important factors were a boarding establishment founded on a strong value system and strict but fair discipline. Parents want boarding schools to have values that are not only communicated but are entrenched in school behaviours and traditions.

In Zimbabwe, every parent had the right to send his or her children to a school in the particular area or zone where he or she lived. However, because the schools in the black townships were overcrowded, the government decided to rezone the schools. The new zones meant that parents residing in townships had a choice. They could either send their children to the local school or have them commute to schools in or near the centre of town (Frederickse, 1992, p. 22-23). In a study conducted by Frederickse, the following reasons for parents' preference of



senior high schools in town were identified: The schools in town have high expectation for students and so put pressure on students to become ambitious. Parents also mention that the schools had good facilities for extra-curriculum activities especially in the area of sports, where the schools had all the sport equipment. The progress in the town schools (as in yearly academic results) was indicated as better than in township schools. There were other factor sthough, but were rated very low and also those factors do not relate to the Ghanaian situations.

Opare (1998) in Ghana conducted a study to seek explanation for the increased preference of Ghanaian parents for single-sex secondary schools for their children. The results showed that socio-economic status in most cases determines the type of school parents will choose for their child or children. Opare noticed that higher-status parents tend to choose single-sex schools more than less high-status parents do. If single-sex schools and mixed-sex schools charge comparable fees, then something inherent in single-sex schooling may account for their relative popularity. That something is the opportunity for social reproduction and social mobility. These findings added some dimensions to the current study.

In order to understand how the cost and quality of education as well as family social-economic background interact with school choice decisions, Akaguri (2011) surveyed 536 households in three poor rural communities of Mfantseman District, Central Region, Ghana. The data mainly generated via questionnaire were used to examine the difference in cost between public and

private provisions of education, and to explore those factors associated with school choice and the related expenditure. In addition, to gain further insight into the implications of the survey's statistical outcomes, a number of participants with interests in both public and private schools were interviewed – including 38 household heads in the lowest income quintile, 6 head teachers, 14 teachers, eight parents, seven Parent Teacher Association (PTA) executives and three School Management Committee (SMC) executives with children in both school types.

The findings rejected their hypothesis that school choice in the communities under study was not affected by socio-economic factors, since the majority of households had no real option. In particular, the prohibitive cost of fees at both types of school, but compulsoriness at private schools (this is because private schools dominate in the study area. There is very few public schools.), had adverse consequences on the willingness of parents to send their children there. However, a minority of low income level households that did access private schools were able to do so due to school practices such as flexible fee schemes, teacher discipline and better interaction with parents, as well as through assistance obtained via social networks. In addition, the study also found that private schools had a better track record in external examination than public schools in the communities under study. What was clear was that, this better external examination track record by private schools coupled with higher aspirations that some poor households have for their children fuelled interest in private schooling.

The study concludes that the claim that the rural poor access private schools in numbers has been exaggerated. This is because it is the relatively

better-off households that enrol their children in private school, while a minority of the poor that access private schools are able to do so because of manipulative school practices and the nature of its interaction with parents. As a result, the study suggested that it would be in the interests of the poor if rural public schools were improved – including the provision of free school meals – given that greater state support to the private education sector would only benefit the relatively better off. Finally, fee-free public schooling facilitated by the capitation grant should ensure that schools are more accountable to the communities they serve – schools should be made to show how the grant was used to improve access and quality and together with the community set targets for improvement. Improving academic quality and teacher discipline would enable them to restore their image in rural communities and hence encourage demand for public education.

According to Ajayi (2011), parents' socio-economic characteristics or background thus influence the choice of school for their children. In his *Welfare Analysis of School Choice Reforms in Ghana*, Ajayi observed that because parents are not privy to the final external examination result of their children before selecting a particular school, and also the fact that the centralized school choice system in Ghana limits the number of schools parents can choose, uneducated or less educated parents who usually earn very low incomes lack the capacity to fish for the needed information for any proper considerations of the institutional factors before choosing a school. Such parents just consider their socio-economic circumstances and settle on any senior high school nearby with

less complex admission standards and which they can easily afford, as their first choice and the second to the sixth choice, at best choose at random.

On the other hand, Ajayi (2011) also observed that well endowed parents are able to use their rich financial capital (i.e., engaged in a gainful employment or earning very high income), human capital (level of education of parents) and social capital (i.e. parents social networks like knowing some influential people in a school who could help get admission for their children, or knowing some influential people who attended that school or being an old boy or girl of a school) to seek the needed information on admission chances and such pertinent institutional factors like the academic reputation, qualified teachers, teacher commitment, quality and attractive programmes, discipline and conducive learning environment of the school to make the best of choices.

Ajayi (2011) then concludes that these findings suggest that the elimination of school choice constraints like not limiting parents on the numbers of applications they can submit in centralized choice-systems could potentially lead to decreases in parents choosing schools along socio-economic characteristics to increases in choosing schools along institutional dimensions.

### **Understanding School Choice in a Developing Country Context**

The word 'choice' according to English Thesaurus Dictionary means option, alternative, selection or variety. However, when used in education – school choice, it connotes choice between schools. Goldring and Philips (2008) see school choice as any policy that is designed to reduce the constraints that current school systems place on schools, parents and students. Goldring and

Philips were writing in the context of developed countries like the United States and United Kingdom where catchment area restriction prevented some households to access schools of their choice. They noted that school choice takes several forms including choice among public schools within a particular district, choice across districts and public-private school choice. But as Srivastava (2008) notes, catchment area restriction does not apply in developing countries in Asia and Africa as parents are free to choose any school within and across districts.

Nevertheless, choice could still be constrained by other factors including distance and cost. Again, unlike in the US or Chile, for example, where increased school choice was the result of the provision of vouchers (Patrinos, Barrera-Osorio & Guaqueta, 2009) to poor households, increased choice in developing countries resulted from increased private provision (Srivastava, 2008). As a result, to be able to understand the school choice environment in developing countries, particularly in poor areas of Africa, it needs to be examined within a distinct choice system.

Tooley (2009) makes a distinction between two types of school choice - choice within a state regulated and publicly funded schooling system in the school choice market, where the state is not a monopoly supplier and funder of education. The school choice market in Ghana is characterised by growing range of private schools entirely self-funded through tuition charges, often owned by a sole proprietor, and are operated and managed through a set of informal rules and regulations set by owner (s) of the school (Akaguri, 2011).

In urban environments, households with economic resources have the leverage to enrol in a school of their choice. However, in a typical poor rural environment, this might not be the case for the majority of households due to poverty. School choice has to do with affordability expressed in terms of the proportion of household income that is expended on education (Lewin, 2007). Lewin (2007) notes also that household survey has shown that the poor usually allocate about five percent and rarely more than 10 percent of household expenditure to education of a single child in public secondary school.

Therefore, if household educational expenditure per child goes beyond 10 percent of their income, this would have serious implications on household expenditure patterns. As a result, Harma (2008) argues that real school choice has to do with a household's ability to pay school fees and related expenses without cutting back on basic household needs such as food, medical care and other household essentials. Thus, the mere decision to enrol in a fee-paying private school does not connote real choice, especially if households have to spend significant proportion of their income on just one child (Harma, 2009). Therefore, when Tooley (2009) argues that the poor households are choosing low-fee private schools, this seems to be confusing the issue about school choice because the majority of the poor in rural settings still have no real choice.

### **Conceptual Framework**

The conceptual framework for this study took into consideration all possible factors from the literature and from observations to derive the dependent, independent and mediating variables for descriptive and inferential analysis. The

dependent variable is parents' choice of a particular SHS while schools institutional factors, parents socio-economic and social factors constitute the independent variables. The conceptual framework is illustrated in Figure 1.

Parents' choice of a particular SHS for their children is influenced by school institutional factors, parents' socio-economic status and social network factors. School choices that the study considers are public versus private SHSs and co-education versus single-sex SHSs. These form the dependent variable of the study. The study agrees that the schools institutional factors, parents socio-economic and social factors do influence parents' choice of a particular SHS for their children or children positively.

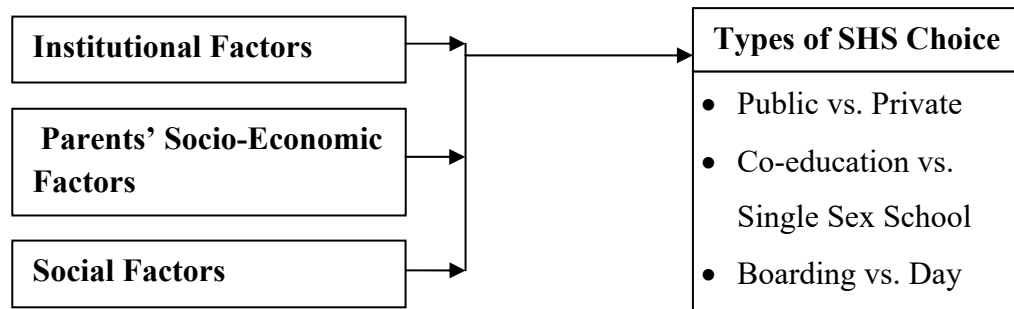

**Figure 1.** Conceptual framework for factors that influence parents' choice of a SHS for their children

The dependent variable is the type of SHS chosen by parents, which is categorised as public or private SHS, co-education or single-sex SHS and boarding or day SHS. The independent variables are identified as factors that influence parents' choice of SHSs, which are made up of various variables such as qualified teachers, excellent academic record, teacher commitment, attractive and conducive learning environment, school climate, class size, parental involvement, affordability, religious orientation and extra-curricular activities. The explanation of the individual variables has been well dealt with in the literature. The study

hypothesised that school institutional factors, parents socio-economic status and social network factors positively influence parents' choice of a particular SHS for their children.

In summary, what do studies of parental choice for a type of schools reveal? First, parents, regardless of where they live, will exercise the exit option if they feel the educational needs of their children are not and will not be met by the public school system. Second, parental choice of a particular school also seems to be influenced by the particular needs of children as perceived by the parents. For example, parents for whom religion is an important aspect of their lives will more often select a private school with a religious orientation than a public secular school. Religion and moral values have a higher premium for these parents.

The review also suggests that explicit religious reasons were not mentioned as frequently by parents in more recent studies, but this could also be due to the nature of the questions and the list of factors parents were asked to respond to were different from older studies. The variance in what parents select as the major or most important factor will vary according to the needs of the children, the perceptions and value of the parents about a school and education, and the financial status and level of education of the parents. Third, in general the literature review found that the main reasons that surfaced in the data irrespective of the school choice sets or school choice system and also, the wording were; excellent academic record, teacher qualification and commitment, proximity of school to home, discipline, small class size, extracurricular activities or



opportunities, cost or affordability, parental involvement, parent's social-economic background and parent's social network factors.

## **CHAPTER THREE**

### **METHODOLOGY**

The chapter explains how the study was conducted. It states how the researcher collected the data and the method he used for analysing the data collected from the field. It discusses the various methods that were employed in generating research data to answer the research questions and hypotheses. The following sub-headings are discussed: research design, population, sample and sampling procedure, instrument, pre-testing of the instrument, data collection procedure, and data analysis.

#### **Research Design**

The study seeks to look into the factors that influence parents' choice of a particular SHS for their children, focusing on the perspective of parents' within the Cape Coast Metropolis whose children are currently in SHS. Since the study entails a survey of parents' views on the issues, the descriptive survey design was deemed the most appropriate research design. Descriptive research design involves systematic gathering of data about individuals and collectivities in order to test hypotheses or answer research questions concerning the current status of the subject of the study (Ary, Jacobs, Razavieh & Sorensen, 2006). It determines and reports the way things are. Saunders, Lewis and Thornhill (2007) consider this design to be wholesome when information is needed about conditions or

relationships that exist; practices that prevail; beliefs, points of view, or attitudes that are held.

In the view of Ary et al. (2006), this type of design is appropriate for it allows the researcher to collect data to assess current practices for improvement. They further point out that the design gives a more accurate and meaningful picture of events and seeks to explain people's perception and behaviour on the basis of data gathered at any particular time. An advantage of a descriptive survey is that it helps the researcher to collect data to enable him draw the relationship between variables and analyse the data. It helps to observe, describe and document aspects of a situation as it naturally occurs (Ary et al., 2006).

However, it is a relatively laborious and time-consuming method. It is susceptible to, or easily influenced by, distortions through the introduction of biases in the measuring instruments, and so on. It is sometimes regarded as focusing too much on the individual level, neglecting the network of relations and institutions of societies. Owing to these disadvantages or challenges, the researcher planned, and organised the independent variable as objectively as possible. The study also presents data systematically in order to arrive at valid and accurate conclusions. The design was used to explore and describe the perception of parents' with regard to the factors influencing parents' choice of SHS for their children. It helped in bringing out the issues, views and the characters as they were.

## **Population**

Population can be seen as the entire aggregation of cases that meet a designed set of criteria (Ary et al., 2006). It must be noted that whatever the basic unit, the population always comprises the entire aggregation of elements in which the researcher is interested in gaining information and drawing conclusions. It can also be seen as the target group about which the researcher will be interested in gaining information and drawing conclusions. The population for the study was all parents in the Cape Coast Metropolis who have at least one child in any of the various SHS within the six educational circuits (Cape Coast Metropolitan Education Directorate [CCMED], 2011).

The study looked into the views of parents' on the factors that influence their choice of SHS for their children. The total number of senior high schools in the metropolis was 16. They are Oguaa Senior High/Technical School, Cape Coast International SHS, St. Augustine's College, Wesley Girls SHS, Mfantipim SHS, Adisadel College, Academy of Christ the King SHS, Aggrey Memorial A.M.E. Zion SHS, Efutu Senior High/Technical School, Ghana National College, Insaaniyya SHS, University Practice SHS, Sammy Otoo SHS, Harris SHS, Pitmas SHS, and Holy child SHS (CCMED, 2011).

## **Sample and Sampling Procedure**

The most used approach for determining the sample in a descriptive study is to specify the precision of estimation desired and then to determine the sample size necessary to insure it (Krejcie & Morgan, 1970; Malhotra & Birks, 2007). Since the total number of parents who are staying in the Cape Coast Metropolis

with at least one child in any of the 16 senior high schools within the Metropolis is unknown, the lottery method of simple random sampling was used to select 14 senior high schools made up of 11 public and three private schools. This forms about 87.5 percent of the total number of senior high schools in the area. The rationale for the choice of 14 schools was to allow for easy generalisation since the distribution of the schools was normal. Furthermore, the number selected is consistent with the recommendation of Malhotra and Birks who posited that in a descriptive study a sample size of 50 percent or more of a given population of institutions or elements is appropriate.

However, due to the small number of parents with at least one child in the selected schools, the census method was deemed appropriate and feasible. The census again was necessary since parents who stay in the metropolis with at least one child in the selected schools were quite different from each other. According to Malhotra and Birks (2010), it is always appropriate to use the census method in studies with defined and small elements. This is so because in such studies, the population is small and variable, any sample the study draws would not be representative of the population from which it is drawn.

The resulting values the study would calculate from the sample would also be incorrect as estimates of the population values. The parents were 294 in number and they were able to provide data that facilitated the examination of the factors that influence parents' choice of a particular senior high school for their children. In getting all the elements for the study, the study further used the snowball sampling procedure to get all the respondents since there was lack of

sampling frames for the study. Also it was difficult to approach some of the respondents in any other way. There was also no specific number for the targeted population.

### **Instrument**

The questionnaire was the sole data collection instrument. A questionnaire is an instrument of predetermined questions to be answered by the respondents. This form of instrument is based on strict procedure and is of a highly structured form. The same instrument was used on respondents who could not read and write. In reality with regard to some of the elements, the questionnaires were read by the researcher as presented in the instrument. The rigid structure of the questionnaire determines the operations of this research instrument and allows no freedom to make adjustment to any of its elements, such as contents, wording or order of questions.

The researcher was aware of the disadvantages in using questionnaire, especially regarding its construction (Ary et al., 2006). Saunders et al. (2007) are of the view that, questionnaire is less effective than other methods when detailed information is required. But it also offers high anonymity than other methods such as interview guide. This instrument helped the researcher in collecting reliable and reasonable data within a relatively short space of time.

The questionnaire was made up of three sections: A, B and C. All the items, with the exception of item three in section 'A', were close-ended items. Section 'A' dealt with respondents characteristics. Items considered were gender, highest level of education, number of children, parents' income level, parents'

employment status and family status. Section B contained 30 statements on school institutional factors, parents' socio-economic status and parent's social network factors influencing parents' choice of a particular SHS. The section is made up of 30 items. All the items in section B adopted a six-point Likert-type scale ranging from 'disagree totally' to 'agree totally' and the responses to items were scored from one (1) to six (6) respectively. Thus: agree totally (6), strongly agree (5), agree (4), disagree (3), strongly disagree (2), and disagree (1). Items 13 and 14 of this section adopted a five-point rating scale ranging from 'poor' to 'excellent' while the last item adopted four-point scale ranging from 'to no extent' to 'to a very large extent'.

Items in Section 'B' were grouped into school institutional factors, parents' socio-economic status and social network factors. The items were adopted from Dahari and Ya (2011) to suit the current study. According to Dahari and Ya such factors are multi-feature in construct, dynamic and therefore it is essential to assess and evaluate each factor. Sample items from institutional factors include: the school has qualified teachers, teachers in the school are committed to the school, the school offers quality and attractive programmes, the school has an excellent academic record, the school is not too far away from where we live, discipline is high in the school, the school is a boarding school, the school has a conducive and attractive learning environment, the school has clean and hygienic conditions, and the school has high expectations and standards for students.

The dependent variable that is, parents' choice of a type SHS were covered in Section C of the instrument. It was made up of close-ended items from which respondents were to indicate their choice of school. The first sets of items were measured categorically using discrete values. With regard to the second set of items in the section, a six-point scale ranging from disagree totally to agree totally was used to measure the response, one was used to represents the least agreement to the issues while six represented the strongest agreement to the issues.

The Likert-scale used is a method of measuring people's attitudes by combining their scores on a variety of items into a single index. According to Likert (as cited in Saunders et al., 2007) scaling is achieved by ensuring that high-scoring and low-scoring individuals differ in their responses on each of the items selected for inclusion in the index, and the distance is assumed to be the same between categories. Malhota & Birks (2007) posit that the Likert scale is the most widely used method of scaling in the social sciences today. Perhaps this is because they are much easier to construct and because they tend to be more reliable than other scales with the same number of items.

### **Validity and Reliability of the Instrument**

Pallant (2001) explained validity as a term describing a measure that accurately reflects the concept it is intended to measure. In this regard validity simply refers to how accurate the questionnaire was able to collect the responses from the respondents as intended by the researcher. Validity is the degree to which the study accurately answers the questions it was intended to answer. It



examines the truthfulness or the quality of the research process and the accuracy of the results. Gravetter and Forzano (2006) on the other hand defined content validity as the degree to which a test measures an intended content area. For them, content validity is determined by expert judgment and that content validity cannot be calculated through quantitative technique.

To enhance the validity of the research instrument, the questionnaire was made available to the researcher's supervisors, both the principal and the co-supervisor, to review and comment on with the view of establishing content validity. Under the guidance of the principal supervisor, the researcher modified and deleted materials he considered inaccurate or which the study felt infringed on the confidentiality of the respondents. My two supervisors further scrutinised unclear, biased and deficient items, and evaluated whether items were members of the subsets they have been assigned.

Reliability is the degree of stability or consistency of measurement (Gravetter & Forzano, 2006). In finding the reliability of the instrument, it was pilot-tested in February, 2013, on a sample of 30 respondents in the Komenda-Edina-Eguafo-Abrem (KEEA) Municipality to refine it. The number of respondents used for the pilot study was sufficient to include any major variations in the population as confirmed by Ary et al. (2006) that for most descriptive studies using questionnaires, a range of five to ten percent (5% - 10%), of the sample size, for pilot study is sufficient. The respondents were selected because they share similar characteristics as those in the Cape Coast Metropolis. These

selected respondents at the KEEA Municipality were also selected due to their closeness and easy accessibility to the researcher.

The instrument was administered personally to the respondents. The internal consistency of the instrument was calculated using Cronbach's alpha. The Cronbach's alphas of the instrument generated was 0.782 with the help of Test Analytics for Surveys (TAfS), a tool of Predictive Analytic Software (PASW) Version 18.0, which is used for coding data and analysing verbatim responses to close and open-ended questionnaire and produces tables and charts directly to enable data interpretation (See Table 1).

**Table 1: Computed Reliability Co-efficient of the Instrument**

Questionnaire Category	No. of Items	Sample Size	Cronbach's Alpha
Section A: Personal characteristics	6	30	.710
Section B: Factors influencing parents' choice	30	30	0.755
Institutional factors	22	30	0.845
Parents socio-economic status	2	30	0.651
Social network factors	6	30	0.714
Section C: Parents' choice of type of SHS	12	30	0.701

Further calculation of reliability of the questionnaire was done on construct and variable bases. This statistical validation on the Likert-type scale of the items in the sections was based on the Cronbach's alpha reliability test. With the help of the same statistical software the internal consistency of the Likert-type scales and the demographic data for Cronbach's alpha co-efficient was

determined. There was 100 percent response rate. The reliability co-efficient of the sections are presented in Table 1.

Research has shown that scales with Cronbach's alpha co-efficient of 0.70 or more are considered to be reliable (Pallant, 2001). Based on the responses given during the pre-testing of the instrument, few modifications were effected to improve the final instrument for the main survey which was then administered. Items that were not clearly stated were corrected.

### **Data Collection Procedure**

The researcher negotiated access to the respondents by collecting a letter from the Department of Educational Foundations which was presented to the heads of the selected senior high schools to seek their permission to elicit information on some students randomly with regard to their parents' address. This helped in the data collection and facilitation of the administration of the instrument. Since the researcher already had the contacts of some of the respondents and opinion leaders in the society, they were notified ahead of time on phone. The leaders/chairpersons of the various Parents and Teachers Association (PTA) in the schools were contacted by the help of the heads for permission to administer the instrument in their first general meeting. Fortunately, all the PTA chairpersons accepted the request and the instruments were administered as scheduled.

With the help of a trained qualified assistant and some identified parents' in the study area, some of the sample elements who were not captured at the meetings were approached by the researcher in their respective homes to seek

their consent and to elicit data from them. The data collection process was done on agreed dates and direct notes, snap shots, observation as well as audio recording were taken to enrich the research. For those who could read and write the researcher read the items to them and guided them to answer. In other words, the questionnaires were administered as interview schedule to those who could not read and write. This allowed the researcher to administer it to both those who could read and write and those who could not read and write at the same time. This is one of the advantages of questionnaire. It can be used as an interview schedule, that is, a questionnaire that is answered by the researcher but not the respondents.

Some of the respondents captured during the administering of the instrument at the various PTA meetings had the characteristics that were required of them others were also already noticed by the researcher. These groups of respondents were used as informants to identify other respondents who qualify for inclusion and these (i.e. those identified) in turn identify yet others. In other words, the researcher subsequently asked the few respondents available to recommend other parents' who were not captured during the meeting yet meet the criteria of the research and might be willing and able to participate in the project.

If and when such respondents were recommended, the researcher and other interviewers approached them, collected the data required, and asked them to recommend other persons who might fit the research design and willing to be studied. This process continued until the required numbers of respondents were obtained. The purpose of reading the questionnaires to some of the respondents

was mainly to elicit responses from parents' who the researcher believe were not highly educated to understand the items in the instrument as expected. This is the main reason why some of the identified parents' were subjected to the interview process.

### **Data Analysis**

The data elicited from the respondents were first grouped for editing. After editing, they were coded using numerical values (coded manual) for the variable view of the Predictive Analytic Software (PASW) Version 18.0. Test Analytics for Surveys (TAfS), a tool of PASW, was used for coding the data and analysing verbatim responses to close and open-ended items in the questionnaire and produced tables and charts directly to enable data interpretation.

After this, the data were inputted into the data view to complete the keying in process. After these were done, the data were cleaned, analysed and transformed into tables and extracted for the presentation and discussion in Chapter Four. The tables were used for illustrations in order to clarify meaning and enhance understanding. Cross tabulation was used to analyse the data regarding the background information while data on research question one were analysed using multiple regression analysis. Data on research question two were analysed using frequency, percentage, and mean. Data on research question three were analysed using frequency and percentage. Mean, median standard deviation and skewness were used to analyse data on research question four. With regard to the data relating to the research hypotheses, Pearson Product Moment correlation was used to test the first, second and third hypotheses at 0.05 significance level.



## **CHAPTER FOUR**

### **RESULTS AND DISCUSSION**

The purpose of this study was to identify the pertinent factors affecting parents' choice of SHS in Ghana. Specifically, the study identified the type of SHS parents in the Cape Coast Metropolis choose for their children. Again, the study examined some of the school institutional factors that parents look for in deciding the choice of a particular SHS for their children and how positively or negatively do parents perceive the schools institutional factors, their socio-economic status and social network factors when choosing an SHS for their children.

Similarly, the study looked at the relationships that exist between schools institutional factors, parents' socio-economic status and social network factors and parents' choice of a particular SHS. Furthermore, the study analysed the positive contribution of school institutional factors, parents' socio-economic status and social network factors on parents' choice of a particular SHS. Cross tabulation, frequency, percentages mean, median, standard deviation, skewness, Pearson product moment correlation, and multiple regression analyses were used to analyse the background information, research questions and hypotheses.

The chapter presents the findings emanating from the data collected from the questionnaire. The discussion includes the interpretation of the findings in

reference to previous findings and theory. The chapter is organised into two main parts. The first part deals with the background characteristics of the respondents while the second part is devoted to responses given by the respondents in accordance with the research questions and hypotheses of the study.

### **Background Characteristics of Respondents**

This section deals mainly with the distribution of the respondents by gender, highest level of education, number of children respondents have, family employment status, and income level of respondents. The results are presented in Tables 2 to 5:

**Table 2: Distribution of Respondents by Highest Level of Education**

Highest Level of Education	Gender of Respondents				Total	
	Male		Female		No.	%
	No.	%	No.	%		
No formal education	3	1.7	0	0.0	3	1.0
Basic education	24	13.8	6	5.0	30	10.2
Secondary education	21	12.0	27	22.5	48	16.4
Diploma/Bachelor's degree	57	32.8	51	42.5	108	36.7
Post-graduate degree	69	39.7	36	30.0	105	35.7
<b>Total</b>	<b>174</b>	<b>100</b>	<b>120</b>	<b>100</b>	<b>294</b>	<b>100</b>

Table 2 shows that the proportion of respondents with Diploma/Bachelor's Degree as their highest level of education was the highest (36.7%). Next to them in size were those with Post-Graduate Degree (35.7%). The remaining groups



were those who possessed Secondary Education (16.4%), Basic Education (10.2%), and Non-Formal Education (1.0%). This means majority (72.4%) of the respondents had their education up to the tertiary level. The results show that majority of the respondents can read and write. Therefore, it was appropriate to use the questionnaire since it gives room for the researcher to elicit data from those that can read and write and at the same time from those that cannot read and write.

The distribution of the number of children the respondents had is presented in Table 3. The study was to capture only parents with at least one child in the selected senior high schools. The Table presents the number of children respondents had based on range.

**Table 3: Distribution of Respondents by the Number of Children**

Respondents number of children	Gender of Respondents				Total	
	Male		Female		No.	%
	No.	%	No.	%		
1 – 2 children	78	44.8	51	42.5	129	43.9
3 – 4 children	51	29.3	60	50.0	111	37.8
5 – 6 children	33	19.0	3	2.5	36	12.2
7 children or more	12	6.9	6	5.0	18	6.1
<b>Total</b>	<b>174</b>	<b>100</b>	<b>120</b>	<b>100</b>	<b>294</b>	<b>100</b>

As contained in Table 3, more (43.9%) of the respondents had 1 – 2 children, followed by those that had 3 – 4 children (37.8%). The Table further

shows that half (50.0%) of the parents who were females had 3 – 4 children. Based on the combined percentage, it is clear that majority (81.7%) of the respondents had less than five children.

Table 4 contains findings on respondents’ family employment status. As presented in the Table, majority (59.1%) of the respondents belong to a family status in which both parents are working. However, 32.7% of the respondents’ family employment status was one parent working family status. Table 3 also shows that only 8.2 percent of the respondents belong to families that none of the parents are working. The study further elicited data on the family status of the respondents. The results show that most of the respondents had both parents household family status.

**Table 4: Distribution of Respondents by Family Employment Status**

Family employment status of respondents	Gender of Respondents				Total	
	Male		Female		No.	%
	No.	%	No.	%		
None of the parents are working	18	10.3	6	5.0	24	8.2
One parent working	66	37.9	30	25.0	96	32.7
Both parents working	90	51.8	84	70.0	174	59.1
<b>Total</b>	<b>174</b>	<b>100</b>	<b>120</b>	<b>100</b>	<b>294</b>	<b>100</b>

The distribution of respondents by their income level is depicted in Table 5. The Table shows that more (40.9%) of the respondents income level was above

GH¢1000.00 while 26.5% of the respondents income levels in a month were within the range of GH¢750.00 – GH¢1000.00. The combined percentage from the Table shows that majority (67.4%) of the respondents income level in a month was more than GH¢750.00.

**Table 5: Distribution of Respondents by Income Level**

Income level of respondents in month	Gender of Respondents				Total	
	Male		Female		No.	%
	No.	%	No.	%		
Less than GH¢100.00	3	1.7	6	5.0	9	3.1
GH¢100.00 – GH¢250.00	6	3.4	0	0.0	6	2.0
GH¢251.00 – GH¢500.00	33	19.0	15	12.5	48	16.3
GH¢501.00 – GH¢750.00	15	8.6	18	15.0	33	11.2
GH¢750.00 – GH¢1000.00	39	22.4	39	32.5	78	26.5
Above GH¢1000.00	78	44.9	42	35.0	120	40.9
<b>Total</b>	<b>174</b>	<b>100</b>	<b>120</b>	<b>100</b>	<b>294</b>	<b>100</b>

### **Analyses Pertaining to the Research Questions and Hypotheses**

This section deals with the analyses of the research questions and hypotheses. The Predictive Analytic Software (PASW) Version 18.0 was used to analyse the study. Statistical tools such as cross tabulation, frequencies, percentages, mean, median, standard deviation, skewness, Pearson Product Moment correlation, and multiple regression of the PASW were used to tackle the research questions and hypotheses. The results are presented as follows:

## **Research Question One**

### **What factors influence parents' choice of a particular SHS for their children?**

The first research question of the study focused on the factors influencing parents' choice of a particular SHS for their children. The argument was that schools institutional factors, parents' socio-economic and social factors do contribute significantly and positively to parents' choice of a particular SHS. As discussed earlier, the multiple regression analysis is used to examine this contribution. Institutional factors, parents' socio-economic status and social network factors were treated as the independent variables while parents' choice of a particular SHS was treated as the dependent variable. Parents' choice of a particular SHS for their children which was the dependent variable was obtained by pooling the eight items that were used to elicit data on the issues of school choice. The results are presented in Table 6.

As depicted in Table 6, the multiple regression analysis involved testing of the fourth hypothesis that schools institutional factors, parents' socio-economic status and social network factors do not contribute significantly and positively to parents' choice of a particular SHS. The three factors were entered as independent variables in the regression model and they contributed significantly to parents' choice of a particular SHS for their children. The Table further shows that the most contributing factors in terms of importance are institutional factors ( $\beta = .491, p < 0.01$ ), parents socio-economic status ( $\beta = .462, p < 0.01$ ) and social network factors ( $\beta = .402, p < 0.01$ ). This means that the institutional factors are

the most contributing factor that influences parents' choice of a particular SHS for their children, followed by parents' socio-economic status and social network factors.

**Table 6: Factors Influence Parents' Choice of a Particular SHS for their Children**

Factors	Unstandardised		Standardised	t-values	Sig.
	coefficients		coefficients		
	B	Std. Error	Beta		
Institutional factors	0.579	0.110	0.491	3.449	0.001
Parents socio-economic status	0.518	0.069	0.462	4.592	0.000
Social network factors	0.381	0.048	0.402	3.741	0.000
Constant			0.131		
R <sup>2</sup>			0.502		
Adjusted R <sup>2</sup>			0.494		

Dependent variable: Parents choice of a particular SHS for their children

\*\*p<0.01

(N = 294)

The total contribution of the independent variables to the variance in the dependent variable is 0.502 with an adjusted R<sup>2</sup> of .494. This means that institutional factors, parents' socio-economic status and social network factors are able to predict or explain about 50 percent of the variance in parents' choice of a particular SHS for their children. The findings are in line with that of Parker et al. (2007) who found out that most parents dwell much on institutional factors when

choosing a particular SHS for their children. The findings again corroborate that of Ajayi (2011) who posits that parents' socio-economic characteristics influence their choice of a particular school for their children. Ajayi added that parents consider the school institutional factors and their socio-economic circumstances before choosing a particular SHS for their children.

### **Research Question Two**

#### **Which type of SHS do parents in the Cape Coast Metropolis choose for their children?**

The second substantive research question of the study focused on the types of SHS parents in the Cape Coast Metropolis choose for their children. Types of school choice considered were co-education which is boarding, co-education which is day, single-sex education which is boarding and single-sex education which is day. All these types were to be considered based on their organisational structure as being private or public. The results are depicted in Table 7.

As contained in Table 7, majority (83.7%) of the respondents preferred public school to private school. The Table further shows that in terms of the structure of the schools, majority (62.2%) of the respondents indicated that they prefer single-sex education which is both boarding and public, while, 62.5 percent admitted that they prefer co-education which is both day and private. This means that with regard to public SHS, parents within the Cape Coast Metropolis prefer those that are boarding and single-sex. Furthermore, with regard to private SHS, parents within the metropolis prefer their children to attend those that are day and co-education. In all, majority (57.2%) of the respondents prefer single-sex

education which is boarding. Also, 26.5% of the respondents indicated that they prefer co-education which is boarding.

**Table 7: Parents’ Choice of Type of Senior High School**

Types of senior high schools	Public SHS		Private SHS		Total	
	No.	%	No.	%	No.	%
Co-education **	75	30.5	3	6.3	78	26.5
Co-education *	15	6.1	30	62.5	45	15.3
Single-sex education **	153	62.2	15	31.2	168	57.2
Single-sex education *	3	1.2	0	0.0	3	1.0
<b>Total</b>	<b>246</b>	<b>100</b>	<b>48</b>	<b>100</b>	<b>294</b>	<b>100</b>
<b>% Sample size</b>	<b>83.7%</b>		<b>16.3%</b>		<b>100%</b>	

Where \* represents day and \*\* represents boarding

Generally, it therefore means that most parents within the metropolis preferred choice of SHS for their children is senior high schools that have boarding facilities. The finding is consistent with the submissions of Bell (2009) who suggests that senior high boarding schools have become more competitive as schools attempt to attract parents to send their children to these schools and retain already existing students. Bell believes that the closeness of a school to parents’ residence or home is possibly less influential in parental choice of a school, as the boarding school has a far greater role to play in the child’s overall development and wellbeing due to the time spent at the school. So for Bell, the fact that the school is boarding is paramount to parents regardless of its location.

### **Research Question Three**

#### **What are some of the schools institutional factors that parents look for in deciding the choice of a particular SHS for their children?**

The third research question of the study was to find out some of the school's institutional factors that parents look for in deciding the choice of a particular SHS for their children. Nineteen items were used to elicit data on the factors. Some of the factors considered were that the school has qualified teachers, teachers in the school are committed to the school, the school has excellent academic record, the school has boarding facilities and it has conducive and attractive learning environment. Other factors examined were the class size of the school, affordability of fees of the school, religious orientation in the school and the school having good facilities for extra-curriculum activities. The factors were measured on a six-point scale ranging from one to six where one represented least agreement with the factors while six represented highest agreement.

The six-point scale was transformed into two-point scale since numerical numbers were used in coding the responses and also the percentages of the extreme responses were insignificant. The first scale (agree) was made up of agree totally, strongly agree and agree while the second (disagree) was also made up of disagree totally, strongly disagree and disagree. The percentages for the individual factors were computed with the help of Test Analytics for Surveys (TAfS), a tool of SPSS Predictive Analytic Software Version 18.0.

In addition, descriptive statistics were used to describe the views of the respondents. In order to determine the most appropriate descriptive statistics to



use, the researcher performed the test of normality to find out whether the distribution was normal or not. As indicated earlier in the third chapter, the data were cleaned before actually analysing and interpreting the data in order to tackle the objectives of the study. Mean coefficient is used when the distribution is normal while median coefficient is used when the distribution is skew (Ary et al., 2006). According to Ary et al. (2006), in a normal distribution the mean and the median are approximately the same. The skewness values must have a threshold of -0.5 to 0.5.

The skewness values of the distribution were closer to each other and were within an acceptable threshold of a normal distribution (they were within a range of -0.263 – -0.433). The standard deviations (they were within a range of 0.63 – 0.91) were also moderate and closer to each other, indicating the non-dispersion in a widely-spread distribution. The moderateness of the standard deviations of the distribution shows that the views of the respondents were coming from a moderate homogeneous group that is, a group with similar characteristics. That means parents view on factors that influence their choice of a particular SHS for their children is an approximation to a normal distribution. Based on the six-point numerical scale used, the average response score used in grouping the views of respondent with regard to positive and negative views was a mean score of 3.5. That is  $(1 + 2 + 3 + 4 + 5 + 6) / 6 = 3.5$ . The combined percentage distributions of the responses and their corresponding mean scores are presented in Table 8.

**Table 8: Schools' Institutional Factors that Influence Parents' Choice of a Particular SHS for their Children**

School institutional factors	Agree		Disagree		Mean
	No.	%	No.	%	
The school has qualified teachers	95	96.9	3	3.1	5.03
Teachers in the school are committed to the school	94	95.9	4	4.1	4.89
The school offers quality and attractive programmes	97	99.0	1	1.0	4.81
The school has an excellent academic record	86	87.8	12	12.2	4.87
The school is not too far away from where we live	58	59.2	40	40.8	3.86
Discipline is high in the school	89	90.8	9	9.2	4.65
The school is a boarding school	77	78.6	21	21.4	5.02
There is a harmonious interpersonal relationship between students and teachers	88	89.8	10	10.2	4.29
The school has a conducive and attractive learning environment	89	90.8	9	9.2	4.60
The school is popular and quite old	63	64.4	35	35.6	3.92
This school provides adequate support services (ie. counselling, healthcare, social services)	75	76.5	23	23.5	4.14

(N = 294)

**Continuation of Table 8**

---

The school has clean and hygienic conditions	86	87.8	12	12.2	4.41
The school has high expectations and standards for students	94	95.9	4	4.1	4.79
Class sizes are not too large	56	57.1	42	42.9	3.69
Because the school uniform looks attractive	16	16.4	82	83.6	2.32
The school regularly keeps parents informed about how their children are performing academically	91	92.9	7	7.1	4.74
The fees are affordable	62	63.3	36	36.7	3.83
Because of the religious orientation of the school	51	52.1	47	47.9	3.49
The school has good facilities for extra-curriculum activities	75	76.6	23	23.4	4.12

---

(N = 294)

As presented in Table 8, more than 95 percent of the respondents were of the view that they prefer schools that had qualified teachers (96.9%) who are committed to the school (95.9%). The findings are congruent with the view of Smithers (2000) who posits that parents are influenced and interested in schools that they perceive as good; one which had qualified teachers and the teachers are committed to the school and that the school will suit the needs of their children.

Similarly, the findings corroborate with that of Parker et al. (2007) who found out that teacher quality, which also meant qualified teachers, is one of the key institutional factors that parents considered in choosing a secondary school for their children. Furthermore, almost all (99.0%) of the respondents indicated that they prefer schools that offer quality and attractive programmes. This finding is consistent with the comments of Munro-Hunter (2003) who indicated that parents chose their particular school based on religious considerations, academic quality, as in quality and attractive programmes.

The majority (87.8%) of the respondents agreed that they prefer schools that have excellent academic record. Similarly, 59.2 percent of the respondents admitted that they prefer schools that are not too far away from where they live. The findings are consistent with the literature. Jackson and Bisset (2005) posit that the excellent academic record and prestige of schools are key features guiding parents' school choices and that these factors are particularly important amongst parents who opt for single-sex education for their children. Tooley (2009) also commented that where the location of a school is far away from a child's home or where the school is considered by a household to be unsafe for children, they are more likely to enrol in the nearest and safe school even if such a choice would imposed heavy cost burden on the household.

Table 8 further shows that greater number (90.8%) of the respondents prefers choosing schools with high discipline as one of it cultures. The finding support that of Poll (1969) who found out that the reasons for choosing a particular school by parents are religious orientation and the desire for stricter

discipline. Similarly, 78.6 percent of the respondents agreed that they prefer choosing senior high schools that are boarding. In other words, they prefer schools that had boarding facilities. The finding avers the views of Dahari and Ya (2011) who indicated that one of the important factor that parents look forward to when choosing a particular school for their children is the availability of boarding facilities.

The majority (89.8%) of the respondents agreed that they prefer schools that there is harmonious interpersonal relationship between students and teachers. The finding is in line with the view of Noden (2000) who posits that a school that establishes a harmonious interpersonal relationship between students and teachers may not go unnoticed by potential customers. When parents visit a school they intend to select for their children, they observe how the teachers interact with the students. Do they approach the students with warmth and care and appear happy while doing their job? Do the teachers sit next to the students and work together with them, or do they supervise the students from a far? Once again, parents must consider their children's needs. Some students respond best to teachers that exhibit a lot of physical warmth, for example hugging. It is important that teaching and support staff establishes harmonious and interpersonal relationship with students and treat them like family members.

Also, a large chunk (90.8%) of the respondents indicated that they prefer schools that have conducive and attractive learning environment. The finding confirms that of Daugherty (1991) who found out that the most prevalent reasons parents consider in choosing a particular school were on the basis of quality

teachers and secure environment which invariably create conducive learning environment. With regard to the school popularity and its long existence, 64.4 percent of the respondents agreed that it influences their choice of a particular school for their children. Majority (76.5%) of the respondents agreed that they prefer choosing schools that provide adequate support services such as counselling, healthcare, and social services to its students. The finding is consistent with the view of Vigar-Ellis (2013) who commented that support services like counselling, health and social services offered in boarding schools are adequate and taken more seriously since most parents take note of these services when choosing a school for their children.

A greater number of the respondents were of the view that they prefer choosing a particular SHS for their children if the school has clean and hygienic conditions (87.8%) and also if the school has high expectations and standards for students (95.9%). The findings are consistent with the suggestion of Lauder milk (1994) who suggested that in choosing SHS parents are usually influenced by the expected high expectation the school has for its students, the conducive and attractive learning environment of the school and the extracurricular opportunities available in the school.

Furthermore, the findings corroborate with the views of Dahari and Ya (2011) who posited that the cleanliness and hygienic conditions of the school is another important factor that parents look forward to when choosing a school. Hygiene and cleanliness are especially important to ensure student's health and safety. Dirty classrooms, bathrooms and compounds can course skin diseases and

cases of worms' infections to students. With frequent cases of food poisoning and reported cases of cholera at schools because of unhygienic food preparations, dirty eating areas and utensils, parents would check the cleanliness of SHS, especially those that are boarding, before registering their children.

Table 8 further depicts that 57.1 percent of the respondents agreed that they are been influenced by the class sizes of the school they choose. The finding is consistent with that of Taylor (1996) who found out that parents look for a school that would satisfy the individual needs of their children. They also desire a school compatible with their own values, morals, and philosophies. In addition, parents looked for a school that they felt offered academic quality, religious education, small class size, and proximity of the school to their place of residence. Wolfe (2002) also found out that the major reasons why parents choose a specific school for their children are small environment as in small class size, safety, and friends and family influences.

However, 83.6 percent of the respondents disagreed that they choose a particular SHS for their children because the school uniform looks attractive. The means scores show that with the exception of this statement (because the school uniform looks attractive), respondents agreed to all the statements in Table 8. The finding is incongruent with the suggestion of Kingdon (2006) who suggested that the design or the redesign and colour of a school's uniform harmonise the school's vision and message and help present the school to parents or the general public in an attractive way. Also, this findings does not support the researchers own observation concerning knowing some parents who chose a particular senior

high school (Adisadel college) for their children because they “just love” the colour (black and white) of the school’s uniform.

A greater number (92.9%) of the respondents were of the view that they prefer choosing schools that regularly keep parents informed about how their children are performing academically for their children. The finding supports that of Munro-Hunter (2003) who found out that parents chose their particular school based on religious considerations, the school’s environment being conducive for learning and individualised attention and the relationship between home and school. That is; the fact that the school regularly keeps parents informed about how their children are performing academically.

Similarly, 63.3 percent of the respondents were of the view that the affordability of the fees of a particular school also influences their decision in choosing a particular school for their children. The finding supports the submission of Lewin (2007) who posits that in urban environments, households with economic resources have the leverage to enrol in a school of their choice. However, in a typical poor rural environment, this might not be the case for the majority of households due to poverty. School choice has to do with affordability expressed in terms of the proportion of household income that is expended on education. Lewin notes that the poor usually allocate about five percent and rarely more than 10 percent of household expenditure to education of a single child in public secondary school which may be insufficient in this modern world.

As depicted in Table 8, 52.1 percent of the respondents agreed that they choose a particular school for their children because of the religious orientation of



the school. Again, 76.6 percent of the respondents agreed that they choose a particular SHS for their children because the school has good facilities for extra-curriculum activities. The findings are consistent with the comments of Ball and Vincent (2001) who posit that facilities for extra-curriculum activities is sometimes the next thing parents consider after the academic potentials of the school, with the intentions of developing a complete individual. Parents will observe how the school is organised, such as specific areas for different forms of play or games, sometimes referred to as activity centres. These areas usually include arts and crafts, football and hockey pitch, basket and volley ball courts and activities for students to work on individually or in small groups. This tradition of many schools to keep a balance between academic and sports is particularly appealing to many parents.

Sardar (2008) also added that religious orientation is another factor that some parents will hardly gross over. Some parents feel that teaching students' religion is reckoned as one of the most important aspects of family life and is primarily the responsibility of parents. With the emergence of Christian and Islamic civilisation, majority of Christian and Muslim parents would like to have the foundation of Christian or Islamic knowledge for their children. Therefore, they would prefer to send their children to senior high schools with such religious values. For Muslim parents who are looking for good moral and religious values in their children, they will look for senior high schools that are associated with the Islamic religion.

#### **Research Question Four**

**How positively or negatively do parents perceive the schools institutional factors, their socio-economic status and social network factors when choosing a SHS for their children?**

The fourth research question of the study was to ascertain how positively or negatively parents perceive the schools institutional factors, their socio-economic status and social network factors when choosing a SHS for their children. The main variables listed above was made up of many items that were pulled together to form each main variable. The institutional factors construct was made up of 19 items. That of parents' socio-economic status was made up of two items while parents' social network factors construct was made up of six items.

These items were measured with six-point scales ranging from agree totally (6) and disagree totally (1) where one represents the least agreement to the issues while six represents the strongest agreement to the issues. As indicated earlier, each of the main constructs were made up of many items that were pool together using average responses with the help of the Statistical Package for Social Sciences (SPSS) Predictive Analytic Software (PASW) Version 18.0. After the pulling process, descriptive statistics such as mean, median, standard deviation and skewness were used to analyse the data. The results are presented in Table 9.

Based on the six-point scale used, the average response score used in categorising the data into positive and negative was a mean score of 3.5. That is  $(1 + 2 + 3 + 4 + 5 + 6) / 6 = 3.5$ . As contained in Table 9, respondents perceived

both institutional factors (Mean = 4.421, SD = 0.66) and parents socio-economic status positively (Mean = 4.401, SD = 1.035). However, respondents perceived institutional factors more positively than parents' socio-economic status. This means that parents lay much emphasis on both institutional factors and their socio-economic status.

**Table 9: Parents' Perception of Schools' Institutional Factors, their Socio-Economic Status and Social Network Factors when Choosing an SHS for their Children**

Factors	Mean	Median	SD	SK
Institutional factors	4.421	4.000	0.666	0.537
Parents socio-economic status	4.401	4.000	1.035	-0.260
Social network factors	2.895	3.000	1.404	0.474

(N = 294)

*Where SD = standard deviation and SK = skewness*

The findings are consistent with that of Parker et al. (2007) who found out that institutional factors are the major factors parents consider when choosing a particular SHS for their children. The findings further aver the view of Ajayi (2011) who posited that parents' socio-economic characteristics or background thus influence the choice of school they choose for their children. In his Welfare Analysis of School Choice Reforms in Ghana, Ajayi observed that because parents are not privy to the final external examination result of their children before selecting a particular school, and also the fact that the centralised school choice system in Ghana limits the number of schools parents can choose, uneducated or less educated parents who usually earn very low incomes lack the capacity to fish for the needed information for any proper considerations of the

institutional factors before choosing a school. Such parents just consider their socio-economic circumstances and settle on any senior high school nearby with less complex admission standards and which they can easily afford, as their first choice and the second to the sixth choice, at best choose at random.

With regard to social network factors, respondents perceive it negatively (Mean = 2.895, SD = 1.404). This means that respondents do not dwell much on social network factors when it comes to their choice of a particular SHS for their children. The findings are incongruent with the view of Ajayi (2011) who posits that parents social capital such as parents social networks like knowing some influential people in a school who could help get admission for their children, or knowing some influential people who attended that school or being an old boy or girl of a school influence parents to prefer such a school than others. Ajayi further asserts that the main reasons why parents choose a particular school and not others are based on factors such as excellent academic record, teacher qualification and commitment, parental involvement, parent's social-economic background and other social factors.

### **Testing of the Hypotheses**

As indicated earlier, three hypotheses were formulated to examine the fifth objective of the study. Even though researchers have commented a lot on the association between institutional factors, parent's socio-economic status and parent's choice of a particular SHS for their children, others have also commented on the influence these factors have on parents' choice. However, the literature fails to show clear relationships between the variables and the contribution of the

variables to parents' choice of a particular school for their children, especially within the African cultural context.

The main focus of the hypotheses is to examine the relationship between the variables. The individual constructs were made up of many items as indicated earlier. These items were pulled together to form each of the variable. Parent choice of a particular SHS variable was made up of eight close-ended items that were pooled together. These items were measured with six-point scale ranging from disagree totally to agree totally where one (1) represents the least agreement to the issues while six (6) represents the strongest agreement to the items. The Pearson Product Moment correlation was used to test the three hypotheses. The results and discussions are presented in Tables 10.

H<sup>1</sup><sub>1</sub>: There is significant relationship between parents' choice of a particular SHS and schools institutional factors.

H<sup>2</sup><sub>1</sub>: There is significant relationship between parents' choice of a particular SHS and their socio-economic status.

H<sup>3</sup><sub>1</sub>: There is significant relationship between parents' choice of a particular SHS and their social network factors.

**Table 10: Relationship among Institutional Factors, Parents' Socio-Economic Status and Social Network Factors**

Factors	Parents' choice of a particular SHS
Institutional factors	0.340**
Parents socio-economic status	0.330**
Social network factors	0.234**

\*\*p<.01

(N = 294)

The study hypothesised firstly that there is no significant relationship between parents' choice of a particular SHS and schools institutional factors. The data for computing the Pearson Product-Moment Correlation required for these hypotheses were obtained from items nine and 16 of the research instrument (See Appendix) As contained in Table 10, the institutional factors was statistically significant and positively correlated with parents' choice of a particular SHS ( $r = 0.340$ ,  $p < 0.01$ ). Using the suggestion of Ary et al. (2006) for interpreting correlation co-efficient, the association between institutional factors and parents' choice of a particular SHS was moderate. In other words, there was a positive, moderate relationship between institutional factors and parents' choice of a particular SHS. This means that the higher the rating score of a school on institutional factors, the higher the chances that such school would be chosen by parents for their children.

In other words, parents are likely to choose schools with committed and qualified teachers, boarding facilities, clean and hygienic conditions, conducive and attractive environment and affordable fees for the children. The study therefore rejects the hypothesis that there is no statistically significant positive relationship between parents' choice of a particular SHS and schools institutional factors.

The second hypothetical statement made was that there is no statistically significant positive relationship between parents' choice of a particular SHS and their socio-economic status. Table 10 shows that parents socio-economic factors was statistically significant and positively correlated with parents' choice of a

particular SHS ( $r = 0.330, p < 0.01$ ). The association between parent's socio-economic status and parent's choice of a particular SHS was moderate. In other words, there was a positively moderate relationship between parents' socio-economic status and their choice of a particular SHS. This means, when parents' socio-economic status is high, they are likely to belong to a particular social group in the society. High socio-economic status influences them to choose a particular SHS that parents with the same socio-economic status are choosing.

Therefore, parents with same educational and income levels are likely to choose the same particular school for their children since they belong to the same economic and social class. The study therefore rejects the hypothesis that there is no statistically significant positive relationship between parents' choice of a particular SHS and their socio-economic status.

The third hypothesis of the study was that there is no statistically significant positive relationship between parents' choice of a particular SHS and their social network factors. As presented in Table 10, social factors of parents was statistically significant and positively correlated with parents' choice of a particular SHS ( $r = 0.234, p < 0.01$ ). The association between parent's social network factors and parents' choice of a particular SHS was weak. In other words, there was a positively weak relationship between social network factors and parents' choice of a particular SHS. This means, the more parents are having high level of social network factors that is geared toward a particular school, the more they are likely to choose such school for their children. However, this influence is weak. The study therefore rejects the hypothesis that there is no statistically

significant positive relationship between parents' choice of a particular SHS and their social network factors.

The results from the three hypotheses show that there are positive relationships among institutional factors, parent's socio-economic status and social network factors and their choice of a particular SHS for their children. The findings are in line with that of Parker et al. (2007) study. They found out that school institutional factor, such as extra-curricular activities, class size and the price or affordability of the school's fees; parents' socio-economic status and social network factors are main factors that parents consider when choosing a particular SHS for their children.



## **CHAPTER FIVE**

### **SUMMARY, CONCLUSIONS AND RECOMMENDATIONS**

This chapter presents a summary of major findings of the study and the conclusions drawn from the study. The key findings are reported based on the objectives of the study. These are followed by the conclusions and recommendations. The last section provides suggestion for further research.

#### **Summary**

The summary of the study comprised of two parts. The first part focused on the overview of the study while the second part focused on the key findings.

#### **Overview of the Study**

The purpose of the study was to identify the pertinent factors affecting parents' choice of SHS in Ghana. Specifically, the study examines the factors that influence parents' choice of a particular SHS, the type of SHS parents in the Cape Coast Metropolis choose for their children, some of the schools institutional factors that parents look for in deciding the choice of a particular SHS for their children and how positively or negatively parents perceive the schools institutional factors, their socio-economic status and social network factors when choosing a SHS for their children. The study further looks at the relationships that exist between schools institutional factors, parents' socio-economic status and social network factors and parents' choice of a particular SHS.

The study was conducted in Cape Coast Metropolis with a sample size of 294 respondents made up of 174 males and 120 females. The sample was selected using the snowball sampling technique. All elements in the study area were considered. In other words, the census method was used to capture all the elements in the study area. Questionnaire was the sole data that was used in eliciting data from the respondents. The Cronbach's alpha was used to test for the reliability of the instrument. The reliability coefficient was 0.86.

Both descriptive and inferential statistics were used in analysing the data. Specifically, the study made use of statistical tools such as cross tabulation, frequencies and percentages, means, median, standard deviation, skewness, Pearson Product Moment correlation and multiple regression analysis using the Predictive Analytical Software (PASW) Version 18.

### **Key Findings**

The first substantive objective of the study focused on the factors that influence parents' choice of a particular SHS. The main findings that emerged were:

1. Schools institutional factors ( $\beta = 0.491$ ,  $p < 0.01$ ), parents socio-economic status ( $\beta = 0.462$ ,  $p < 0.01$ ) and social network factors ( $\beta = 0.402$ ,  $p < 0.01$ ) contribute significantly and positively to parents' choice of a particular SHS.
2. However, institutional factors are the most contributing factor that influences parents' choice of a particular SHS for their children, followed by parents' socio-economic status and social network factors.

The second objective addressed the type of SHS parents in the Cape Coast Metropolis choose for their children. The main findings that emerged were as follows:

1. The majority (83.7%) of the respondents preferred public schools to private school.
2. Similarly, the majority (62.2%) of the respondents indicated that they prefer single-sex education which is boarding and public.
3. With regard to private SHS, parents prefer their children to attend those that are day and co-education.
4. Generally, most parents within the metropolis preferred choice of SHS for their children is senior high schools that have boarding facilities.

Some of the school institutional factors that parents' look for in deciding the choice of a particular SHS for their children were examined as the third objective and the key findings were that:

1. Majority of the respondents were of the view that they prefer schools that had qualified teachers (96.9%), excellent academic record (87.8%) and adequate support services such as counselling, healthcare, and social services, and teachers who are committed to the school (95.9%).
2. Most (90.8%) of the respondents prefers choosing schools in which discipline is high and there is harmonious interpersonal relationship between students and teachers (89.8%).
3. Large chunk of the respondents indicated that they prefer schools that have conducive and attractive learning environment (90.8%), clean and hygienic

conditions (87.8%) and also if the school has high expectations and standards for students (95.9%).

4. Greater number (92.9%) of the respondents were of the view that they prefer choosing schools that regularly keep parents informed about how their children are performing academically for their children.

The four objective of the study examined how positively or negatively parents perceive the schools institutional factors, their socio-economic status and social network factors when choosing a SHS for their children. The key findings that emerged were:

1. Respondents perceived both institutional factors (Mean = 4.421, SD = .66) and parents socio-economic factors positively (Mean = 4.401, SD = 1.035).
2. With regard to social network factors, respondents perceive it negatively (Mean = 2.895, SD = 1.404).

With regard to the last objective of the study, emphasis was on the significant positive relationship between parents' choice of a particular SHS and schools institutional factors, socio-economic status and social network factors. The main findings that emerged were:

1. There was a positively moderate relationship between institutional factors and parents' choice of a particular SHS ( $r = 0.340$ ,  $p < 0.01$ ).
2. There was a positively moderate relationship between parents' socio-economic status and their choice of a particular SHS ( $r = 0.330$ ,  $p < 0.01$ ).
3. There was a positively weak relationship between social network factors and parents' choice of a particular SHS ( $r = 0.234$ ,  $p < 0.01$ ).

## **Conclusions**

From the findings of the study the following conclusions are drawn:

Parents as consumers or buyers of education services want the best for their children and know what is in their best interests, perhaps more so than schools do. Based on this, parents dwell on both external and internal factors of the schools to determine which school their children should attend. These factors were grouped into three categories that are: institutional factors, parent's socio-economic status and social network factors. The study revealed that all these factors contribute significantly to parents' choice of a particular SHS. However, institutional factors were the most contributing factor that influences parents' choice of a particular SHS for their children, followed by parents' socio-economic factors and social network factors.

It therefore means that senior high schools with qualified teachers, excellent academic record and adequate support services such as counselling, healthcare, and social services are able to attract most parents. Similarly, senior high schools that lay much emphasis on students and academic discipline, harmonious interpersonal relationship between students and teachers, clean and hygienic conditions, and high expectations and standards for students are able to attract most parents in the community.

## **Recommendations**

Based on the key findings and conclusions of this study, it is recommended to parents that they should request from the management of the school to ensure that:

1. Teachers will develop and maintain positive attitude toward students.
2. Heads of the various schools run the school as a business whereas the client is important and the school has to keep on its toes to ensure that it meets the client's demands.
3. Heads of the various schools are attentive to the various institutional factors and create schools that address the needs of the parents in their communities if they are to attract and retain students.

It is further recommend to heads of the various senior high schools within the metropolis to ensure that they treat parents equitably but not equally since their level of education, household income are not the same but are factors that influence their school choice. Furthermore, heads of the schools must understand the dynamics of the community in order to treat parents fairly through positive discrimination since not all parents are socially connected to the school and the community.

### **Suggestions for Further Research**

The following related areas can be researched on to add up to the knowledge of what this study has achieved. First, there is a need to carry out a comparative evaluation of the perceptions of parents, teachers and students on school choice in all regions of Ghana to have a general view of the issues as a whole. Secondly, a research should be done to evaluate the impact of school choice on learners' academic performance. Lastly, a study should be done to establish parents and other stakeholders view on school choice using multiple

instruments. Such a study will help educationists learn and understand the integration of all the stakeholders on school choice and it related issues.

## REFERENCES

- Addae-Mensah, I. (2000, July). *Education in Ghana: A tool for social mobility or social stratification*. Paper presented at the J. B. Danquah Memorial Lectures. Accra: CSIR.
- Adeyinka, A. A. (2001). Secondary schooling and career preference of adolescence in the Eastern and Lagos. *West Africa Journal of Education*, 32(2), 34-45.
- Ajayi, K. (2011). *A welfare analysis of school choice reforms in Ghana*. Berkeley: University of California Press.
- Akaguri, L. A. (2011). *Household choice of schools in rural Ghana: Exploring the contribution and limits of low-fee private schools to education for all*. Unpublished doctoral dissertation, University of Sussex, Sussex.
- Akpakli, J., & Abbey, C. (2012, May 31). Ghana population hit over 24 million. *The Finder* (No. 196), p. 3.
- Anemone, A. (2008). *A descriptive study of the factors influencing middle school choice in a diverse magnet school district in Northern New Jersey*. Unpublished doctoral dissertation, Seton Hall University, Seton Hall.
- Ary, D., Jacobs, L. C., Razavieh, A., & Sorensen, C. (2006). *Introduction to research in education* (7<sup>th</sup> ed.). New York: Thompson/Wadsworth.
- Australian Bureau of Statistics. (2004). *Schools: Australia*. Canberra: Cat. No. 4221.0, ABS.
- Baafi-Frimpong, S., & Yarquah, J. A. (2001). *Development of education in Ghana*. Lecture synopses.



- Bagley, C., Woods, P. A., & Woods, G. (2001). Implementation of school choice policy: Interpretation and response by parents of students with special educational needs'. *British Educational Research Journal*, 27(3), 287-309.
- Ball, S. J. (2003). *Class strategies and the education market*. New York: Routledge Palmer.
- Ball, S., & Vincent, C. (2008). New class relations in education: The strategies of the 'fearful' middle classes. In J. Demaine (Ed.) *Sociology of education today*, (pp. 123-137). Basingstoke: Palgrave.
- Beavis, A. (2006). *Why parents choose private or public schools*. Sydney: Australian Council for Educational Reach.
- Bell, C. (2007). Space and place: Urban parents' geographical preferences for schools. *Urban Review*, 39(4), 19-32.
- Bell, C. A. (2009). All choices created equal?: The role of choice sets in the selection of schools. *Peabody Journal of Education*, 84, 191-208.
- Bisschoff, T., & Koebe, C. (2005). School choice: Challenge to Sharpville public school principles. *South African Journal of Education*, 25, 156-163.
- Bosetti, L. (2001). Can markets save our schools? The Alberta charter school experience. In C. Hepburn (Ed.), *Can markets save our schools?* (pp. 101 – 120). Vancouver, BC: Fraser Institute.
- Brantlinger, E. (2003). *Dividing classes*. New York: Routledge Palmer.
- Buckley, J., & Schneider, M. (2007). *Charter schools: Hype or hope*. Princeton, NJ: Princeton University Press.

- Cape Coast Metropolitan Education Directorate [CCMED] (2011). *Enrolment data*. Cape Coast: Government of Ghana.
- Ceglowski, D. (2007). Play a lot: Children's perception of child care. *Journal of Research in Childhood Education*, 22(2), 183-187.
- Chao, S., & Alper, O. (1998). Accessing basic education in Ghana. *Studies in human development No. 1*. Washington DC: World Bank.
- Colclough, C., Al-Samarrai, S., Rose, P., & Tembon, M. (2003). *Achieving schooling for all in Africa: Costs, commitment and gender*. Hants: Ashgate Publishing.
- Cookson, P. (2002). *The choice controversy*. Newbury Park, CA: Corwin Press.
- Coulson, A. (2005). Measuring market education: Suggestions for ranking school choice reforms. *Cato Journal*, 25(2), 17-29.
- Dahari, Z., & Ya, M. S. (2011). Factors that influence parents' choice of secondary education in Malaysia: An exploratory study. *International Journal of Business and Social Science*, 2(15), 115-128.
- Daugherty, L. D. (1991). *A study of the relationship between enrolment changes and select factors in private secondary schools in the San Francisco bay area*. San Francisco: University of San Francisco.
- Dale, S. B., & Krueger, A. B. (2002). Estimating the payoff to attending a more selective college: An application of selection on observables and unobservable. *Quarterly Journal of Economics*, 117(4), 1491-1528.

- Dustmann, C. (2004). *Parental background: Secondary school track choice and wages*. Oxford Economic Papers. Retrieved March 28, 2013, from www.DOI: 10.1093/oep/gpf048
- Echols, F. H, & Willms, J. D. (2005). Reasons for school choice in Scotland. *Journal of Education Policy, 10*(2), 143-156.
- Eduwed, R. A. (2005). *Essentials of guidance and counselling*. London: Ambik press.
- Edward, S. B., & Richardson, W. M. (1981). *A survey of MCPS withdrawals to attend private school*. Rockville, MD: Montgomery County Public Schools. (ERIC Document Reproduction Service No. EO226096). Retrieved September 28, 2009, from EBSCOHost ERIC database.
- Erickson, D. A. (1981, April 17). *Effects of public money on social climates in private schools: A preliminary report*. Paper presented at the Annual Meeting of the American Educational Research Association, Los Angeles.
- Finn, C. (2001, October). Paragon opinion research Dayton survey: Citizens and parents want reform in education. *Primer: Change Begins With Ideas, 4*(1), 1-9.
- Finn, C., & Kanstoroom, M. (2005). *Afterword: Lessons from the Annenberg challenge. Can philanthropy fix our schools?* Washington DC: The Thomas B. Fordham Foundation.
- Friedman, M. (2003). The role of government in education. In R. A. Solo (Ed.), *Economics and the public interest*, (pp. 123-144). New Brunswick, NJ: Rutgers University Press.

- Frederickse, J. (1992). *All schools for all children: Lessons for South Africa from Zimbabwe's open schools*. Cape Town: Oxford University Press Southern Africa.
- Ginzbering, A., Axeldred, P., & Herma, O. (2011). *School choice: An approach to a general theory*. New York: Columbia University.
- Goldring, E. B., & Bauch, P. A. (1993). *Parent involvement and school responsiveness: Facilitating the home-school connection in schools of choice*. Paper presented at the American Educational Research Association, Atlanta, Georgia.
- Goldring, E. B., & Philips, K. J. R. (2008). Parent preferences and parent choices: The public-private decision about school choice. *Journal of Education Policy, 23*(3), 209-230.
- Gorard, S., & Fitz, J. (2006, December). What counts as evidence in the school choice debate? *British Educational Research Journal, 32*(6), 797-816.
- Gorard, S., Taylor, C., & Fitz, J. (2003). *Schools, markets and choice policies*. London: Routledge/Falmer.
- Gravetter, F. J., & Forzano, L. B. (2006). *Research methods for the behavioural sciences* (2<sup>nd</sup> ed.). Belmont: Thomson Wadsworth.
- Greene, J. (2001) A survey of results from voucher experiments: where we are and what we know. In C. Hepburn (Ed.), *Can markets save our schools?* (pp. 121-149). Vancouver, BC: The Fraser Institute.
- Halstead, M. J. (Ed.) (2009). *Parental choice and education: Principles, policy and practice*. London: Kogan Page.

- Harma, J. (2008). *Are low-fee private schools in rural Uttar Pradesh, India, serving the needs of the poor?* Unpublished doctoral thesis, University of Sussex, Sussex.
- Harma, J. (2009). Can choice promote education for all? Evidence from growth in private primary schooling in India. *Compare*, 39(2), 15-165.
- Harrison, M. (2005). Public problems, private solutions: School choice and its consequences. *Cato Journal*, 25(2), 123-145.
- Harris-Brown, D. (2000, May 3). Charters, vouchers earning mixed report card: The changing face of public education. *Education Week*, 19(34), 23-31.
- Hausman, C., & Brown, P. (2002). Curricular and instructional differentiation in magnet schools: Market driven or institutionally entrenched? *Journal of Curriculum and Supervision*, 17(3), 12-27.
- Hausman, C., & Goldring, E. (2002). Parent involvement, influence, and satisfaction in magnet schools: Do reasons for choice matter? *The Urban Review*, 32(2), 7-18.
- Hawkins, D. I., Mothersbaugh, D. L., & Best, R. J. (2007). *Consumer behaviour: Building marketing strategy*. New York: McGraw Hill.
- Henninger, D. (2005, Sept. 2). Wonder land: To understand Katrina's problems read 9/11 report. *The Wall Street Journal*, 14, 33-41.
- Hill, P. T. (2005). *The supply-side of school choice*. Washington D.C.: Brookings Institute.
- Howe, K., Eisenhart, M., & Betebenner, D. (2002). The price of public school choice. *Journal of Educational Leadership*, 16(3), 97-114.

- Howell, W. (2006). Switching schools? A closer look at parents' initial interest in and knowledge about the choice provisions of no child left behind. *Peabody Journal of Education*, 81(1), 16-30.
- Hoxby, C (2003). *The economics of school choice*. Chicago: University of Chicago Press
- Hunter, A. (2005). *Magnet magic: A consideration of choice and change*. National Association of Secondary School Principals Convention.
- Hunter, J. B. (1991). Which schools? A study of parents' choice of secondary schools. *Educational Research*, 33(1), 31-41.
- Jackson, C., & Bisset, M. (2005). Gender and school choice: Factors influencing parents when choosing single sex or coeducational independent schools for their children, *Cambridge Journal of Education*, 35(2), 195-211.
- Jenkins, S., & Schlueter, C. (2002). *The effect of family income during childhood on later-life attainment: Evidence from Germany*. Discussion Paper No. 604, IZA, Berlin.
- Johnson, C. J. C. (1996). *Parent rationale in selecting private-school education in place of public-school education*. Flagstaff, AZ: Northern Arizona University.
- Kasting, A. (2005). Respect, responsibility and reciprocity: The 3R's of parent involvement. *Childhood Education*, 70(2), 78-97.
- Kelley, J., & Evans, M. (2004). Choice between government, Catholic and independent schools: Culture and community rather than class. *Australian Social Monitor*, 7(2), 31-42.

- Kingdon, G. G. (2006). The quality and efficiency of public and private schools: A case study of urban India. *Oxford Bulletin of Economics and Statistics*, 58(1), 55-80.
- Kleitz, B., Weiher, G., Tedin, K., & Matland, R. (2008). Choice, charter schools and household preferences. *Social Science Quarterly*, 81(3), 846-854.
- Kolderie, T. (2002). *Beyond choice to new public schools: Withdrawing the exclusive franchise in public education*. Washington, D.C.: Progressive Policy Institute.
- Krejcie, R. V., & Morgan, D. W. (1970). Determining sample size for research activities. *Educational and Psychological Measurement*, 30, 607-610.
- Laudermilk, D. (1994). *Exploring reasons parents choose public magnet schools, private schools or home schooling for their children: A qualitative study*. Stillwater, OK: Oklahoma State University.
- Le Grand, J. (2003). *Power to the pawns*. Oxford: Oxford University Press.
- Levine-Rasky, C. (2007). School choice and the analysis of power. *Review of Education, Pedagogy and Cultural Studies*, 29(5), 1-17.
- Lewin, K. M. (2007). The limits to growth of non-governmental private schooling in sub-saharan Africa. In P. Srivastava, & G. Walford (Eds.), *Private schooling in less economically developed countries: Asian and African perspectives*. Oxford Studies in Comparative Education.

- Lucey, H., & Reay, D. (2002). A market in waste: Psychic and structural dimensions of school choice policy in the UK and children's narratives on demonised schools. *Discourse: Studies in the Cultural Politics of Education*, 23(3), 253-266.
- Lynn, L. (2001). Teaching teachers to work with families. *Harvard Educational Letter*, 13(5), 1-7.
- Malhotra, N. K., & Birks, D. F. (2007). *Marketing research* (3<sup>rd</sup> ed.). Harlow: Dentice Hall/Pearson Education.
- Mann, D. (2002). Conditional school deregulation. *Education Digest*, 55(9), 9-21.
- Mapasa, T. E. (2005). *An analysis of factors influencing the choice of particular schools in preference to township schools, in the Port Elizabeth area*. Unpublished master's dissertation, Port Elizabeth Technikon.
- McCluskey, N. (2005, April 20). *Corruption in the public schools: The market is the answer*. Cato Institute, No. 542.
- McDaniel, C., Lamb, C. W. Jr., & Hair, J. F. Jr. (2006). *Introduction to marketing* (8<sup>th</sup> ed.). New York: Thomson South-Western.
- McWilliam, H. O. A., & Kwamena-Poh, M. A. (1975). *The development of education in Ghana*. London: Longman.
- Merrifield, J. (2008). The twelve policy approaches to increased school choice. *Journal of School Choice*, 2(1), 4-19.
- Ministry of Education [MoE] (2009). *Preliminary education sector performance report*. Accra: Ministry of Education.



- Ministry of Education [MoE]/Ghana Education Service [GES] (2001). *Report of the study on the constitutional and legal framework for the right to pre tertiary education*. Accra: MOE.
- Moranto, R., Milliman, S., Hess, F., & Gresham, A. (2001). *School choice in the real world: Lessons from Arizona charter schools*. Boulder, CO: West View Press.
- Munro-Hunter, L. M. (2003). *Private schools in Ontario: Protest of privilege*. Toronto: University of Toronto.
- Noden, P. (2000). Rediscovering the impact of marketisation: Dimensions of social segregation in England's secondary schools, 1994 – 99. *British Journal of Sociology of Education*, 21(3), 371-90.
- Oketch, M., & Ngware, M. (2010). Free primary education still excludes the poorest of the poor in urban Kenya. *Development in Practice*, 20(5), 603-610.
- Oladele, J. O. (2004). *Guidance and counselling a fundamental approach: Focus on education system* (3<sup>rd</sup> ed.). New York: John Lad publishers Ltd.
- Opare, J. A. (1998). Choosing a single-sex school: Elite cloning motive or queue jumping ambition? *Journal of Educational Management*, 1(1), 94-104.
- Osler, A., & Vincent, K. (2003). *Girls and exclusion: Rethinking the agenda*. London: RoutledgeFalmer.
- Pallant, J. (2001). *SPSS survival manual: A step by step guide to data analysis using SPSS for Windows* (Version 10). Australia: Allen and Unwin.

- Patrinos, H., Barrera-Osorio, F., & Guaqueta, J. (2009). *The role and impact of public-private partnerships in Education*. Washington D.C: World Bank.
- Palmer A 2005. *Principles of services marketing* (4<sup>th</sup> ed). New York: McGraw-Hill Irwin.
- Parker R. S., Cook S., & Pettijohn C. E (2007). School Choice Attributes: Positioning a Private School. *Services Marketing Quarterly*, 28(4), 21-33.
- Patterson, J. C. (2001). The truth about school choice. *Curriculum Administrator*, 37(1), 51-69.
- Peebles, D., Wilson, T., Wideman, M., & Crawford, P. (1982). *Admission and withdrawal of elementary school pupils to and from North York public schools: A survey of parents*. Willowdale, Ontario: North York Board of Education.
- Peebles, L. (2000). *Charter school's equity issues: Focus on minority and at-risk students*. Aurora, CO: Mid-Continent Research for Education and Learning.
- Pietrofesa, J., & Splete, P. (2012). *Guidance and counselling: Introduction*. New York: Rend Mentally Ltd.
- Poll, G. (1969). *How the public views non-public schools: A study of the American independent school*. Boston, MA: NAIS.
- Power, S. (2001). Missing: A sociology of educating the middle class. In J. Demaine (Ed.), *Sociology of education today*, (pp. 11-23). Basingstoke: Palgrave.

- Prior, J., & Gerard, M. R. (2007). *Family involvement in early childhood education: Research into practice*. New York: Thomson Delmar Learning.
- Reay, D. (2004). Mostly roughs and toughs: Social class, race and representation in inner city schooling. *Sociology*, 38(5), 1005-1023.
- Reay, D., & Lucey, H. (2003). The limits of 'choice': Children and inner city schooling. *Sociology*, 37, 121-142.
- Robenstine, C. (2000). School choice and administrators: Will principal's become marketers? *The Clearing House*, 74(2), 17-29.
- Sa, C., Florax, R. J., & Rietveld, P. (2003). *Does proximity of schools matter? Choice behaviour of high school leavers concerning academic or professional training*. ERSA Conference Papers Ersa 03 p349, European Regional Science Association.
- Sardar, Z. (2008). *The future of Muslim civilisation*. Petaling Jaya: Pelanduk Publications.
- Saunders, M., Lewis, P., & Thornhill, A. (2007). *Research methods for business students*. London: Pearson Professional Limited.
- Schroeder, J. E., & Salzer-Moerling, M. (2006). *Brand culture*. New York, NY: Routledge.
- Shneider, B., Schiller, K., & Coleman, J. (1996). Public school choice: Some evidence from the national education longitudinal study of 1988. *Education Evaluation Policy Analysis*, 18, 19-29

- Shanker, A., & Rosenberg, B. (2004). *Politics, markets, and America's schools: The fallacies of private school choice*. Washington, DC: American Federation of Teachers.
- Smrekar, C., & Goldring, E. (1999). *School choice in urban America: Magnet schools and the pursuit of equity*. New York: Teachers' College Press.
- Snell, L. (2006, April). The agony of American education. *Reason*, 37(11), 11-19.
- Srivastava, P. (2008). *School choice in India: Disadvantage groups and low-fee 213 private schools, globalisation of school choice?* Oxford: Oxford Studies in Comparative Education.
- Steven, M. (2001). *Kingdom of the children*. Princeton, NJ: Princeton University Press.
- Taylor, R. J. K. (1996). *Variables motivating parents to choose a specific type of private school*. Miami: Florida International University.
- Teske, P., Schneider, M., Buckley, J., & Clark, S. (2000). *Does charter school competition improve traditional public schools?* Stoney Brook, New York: Manhattan Institute for Policy Research.
- Tooley, J. (2009). Choice and diversity in education: A defence. *Oxford Review of Education*, 23(1), 103-116.
- Viaden, D. (2007). Researchers examine school choice picks. *Education Week*, 26(19), 17-29.
- Vigar-Ellis, D. (2013). Boys' boarding school management: Understanding the choice criteria of parents. *South African Journal of Education*, 33(1), 23-39.

- Waddy, C. (2005). *The Muslim mind*. London: Longman Group Limited.
- Walberg, H. J. (2003). Market theory of school choice. *Education Week*, 9(42), 16-23.
- West, A., Varlaam, A., & Mortimore, P. H. M. (2007). *Behaviour problems in schools: An evaluation of support centres* (3<sup>rd</sup> ed.). Beckenham: Universal Press.
- Wolfe, V. D. (2002). *The selection of private schools in Georgia: Perceptions of parents and principals*. Statesboro, GA: Education Administration, Georgia Southern University.
- Yarquah, J. A., Baafi-Frimpong, S., & Atta, E. T. (2011). *Social and philosophical foundations of education*. Lecture Synopses.
- Yidana, M. B. (2000). *Factors influencing female enrolment in educational institutions in Ghana: A case study of West Mamprusi District of the Northern Region of Ghana*. Unpublished master's thesis, University of Cape Coast, Cape Coast.

## **APPENDICES**

**APPENDIX A**

**UNIVERSITY OF CAPE COAST**

**FACULTY OF EDUCATION**

**DEPARTMENT OF EDUCATIONAL FOUNDATIONS**

**Questionnaires for Parents' in the Cape Coast Metropolis**

**THE RESEARCH PROBLEM:** Factors influencing parents' choice of senior high school for their children.

**INTRODUCTION**

Dear Respondent.

This study is being undertaken by a graduate student of the University of Cape Coast. The purpose is solely academic and you are assured of absolute confidentiality. So, please, answer each item as frankly as possible. Please, do not write your name. I wish to thank you so much in advance for your time and co-operation.

**Section A: Parents' Socio-demographic background**

1. Gender Male [    ] Female [    ]
  
2. What is your highest level of education?
  1. No Formal Education [    ]
  2. Basic Education [    ]
  3. Secondary Education [    ]
  4. Tertiary (Diploma; Bachelor's Degree) [    ]
  5. Tertiary (Post-Graduate Degree) [    ]
  
3. How many children/children do you have? .....
  
4. What is your family's employment status
  1. None of the parents is working [    ]
  2. One parent working [    ]
  3. Both parents are working [    ]

5. What is your income level/month

- |                           |   |   |
|---------------------------|---|---|
| 1. Less than GH¢100.00    | [ | ] |
| 2. GH¢100.00 – GH¢250.00  | [ | ] |
| 3. GH¢251.00 – GH¢500.00  | [ | ] |
| 4. GH¢501.00 – GH¢750.00  | [ | ] |
| 5. GH¢750.00 – GH¢1000.00 | [ | ] |
| 6. Above GH¢1000.00       | [ | ] |

6. What type of family is your child in this school living in?

- |                                     |   |   |
|-------------------------------------|---|---|
| 1. Father only household            | [ | ] |
| 2. Mother only household            | [ | ] |
| 3. Both parents household           | [ | ] |
| 4. Father with stepmother household | [ | ] |
| 5. Mother with stepfather household | [ | ] |
| 6. Others                           | [ | ] |

### Section B: Factors Influencing Parents' Choice of School

To what extent do you agree or disagree with the following statements on parents' decision to send their children to a particular senior high school? Please tick [✓] against the one which applies to your choice of response. The response ranges from disagree totally to agree totally where one (1) represents the least agreement to the issues while six (6) represents the strongest agreement to the issues which were rated thus “disagree totally” – 1, “strongly disagree” – 2, “disagree” – 3, “agree” – 4, “strongly agree” – 5, and “agree totally” – 6.

7. Institutional Factors	1	2	3	4	5	6
The school has qualified teachers.						
Teachers in the school are committed to the school.						
The school offers quality and attractive programmes.						
The school has an excellent academic record.						
The school is not too far away from where we live.						
Discipline is high in the school.						
The school is a boarding school.						
There are harmonious interpersonal relationship between students and teachers.						
The school has a conducive and attractive learning environment.						
The school is popular						
This school provides adequate support services (ie. counselling, healthcare, social services).						
The school has clean and hygienic conditions.						



The school has high expectations and standards for students.						
Class sizes are not too large.						
Because the school uniform looks attractive						
The school regularly keeps parents informed about how their children are performing academically.						
The fees are affordable.						
Because of the religious orientation of the school						
The school has good facilities for extra-curricular activities.						
<b>8. Parents' Socio-Economic Status</b>	<b>1</b>	<b>2</b>	<b>3</b>	<b>4</b>	<b>5</b>	<b>6</b>
My level of education influenced me in choosing a school for my children.						
The household income of my family influenced me to choose the kind of SHS my children attend.						
<b>9. Social Network Factors</b>						
Because I know some influential people in the school who could help me to get admission for my children.						
Because I, (i.e. as a parent) attended the same school.						
Because my neighbours children attend the same school.						
Because my children's friends are in that school						
Because it is prestigious to attend that school.						
Because I know some influential people who attended that school.						

10. How would you describe your child's overall academic performance at his/her previous school?

- 1. Poor [     ]
- 2. Below average [     ]
- 1. Average [     ]
- 2. Above average [     ]
- 3. Excellent [     ]

11. How would you describe your child's overall academic performance at his/her current senior high school?

- 1. Poor [     ]
- 2. Below average [     ]
- 3. Average [     ]
- 4. Above average [     ]
- 5. Excellent [     ]

12. To what extent did the academic performance of your child influence you to select the school he/she is attending?

- |                           |   |   |
|---------------------------|---|---|
| 1. To a very large extent | [ | ] |
| 2. To a large extent      | [ | ] |
| 3. To Some extent         | [ | ] |
| 4. To no extent           | [ | ] |

**Section C: (Parents’ choice of types of senior high school)**

13. Which of the following types of senior high school would you like to choose for your children or children?

Type	Public SHS	Private SHS
Co-Education (Boarding)	[ ]	[ ]
Co-Education (Day)	[ ]	[ ]
Single – Sex Education (Boarding)	[ ]	[ ]
Single – Sex Education (Day)	[ ]	[ ]

14. To what extent do you agree with the following statements on school choice? Please tick the appropriate responses ranging from disagree totally to agree totally where one (1) represents the least agreement to the issues while six (6) represents the strongest agreement to the issues thus “disagree totally” – 1, “strongly disagree” – 2, “disagree” – 3, “agree” – 4, “strongly agree” – 5, and “agree totally” – 6.

Statements on school choice	1	2	3	4	5	6
I prefer choosing this particular school in Question 15 for my children because the school has qualified teachers.						
I prefer choosing this particular school in Question 15 for my children because the school has committed teachers.						
I prefer choosing this particular school in Question 15 for my children because the school has conducive and attractive learning environment.						
I prefer choosing this particular school in Question 15 for my children because the school has excellent academic records						

I prefer choosing this particular school in Question 15 for my children because discipline in the school is encouraging.						
I chose this particular school in Question 15 because of the estimated school fees in the school.						
I chose the school in Question 15 because it is easy for me to secure admission for my children						
I choose the school in Question 15 because it is more prestigious for ones child to attend such school in my community						

**THANK YOU VERY MUCH FOR YOUR TIME AND  
COOPERATION**