

UNIVERSITY OF CAPE COAST



ORGANISATIONAL POLITICS ON WORKPLACE INCIVILITY: THE
MODERATING ROLE OF RESILIENCE OF SENIOR STAFF AT THE
UNIVERSITY OF CAPE COAST, GHANA.

DORIS ADUSU

2023

UNIVERSITY OF CAPE COAST

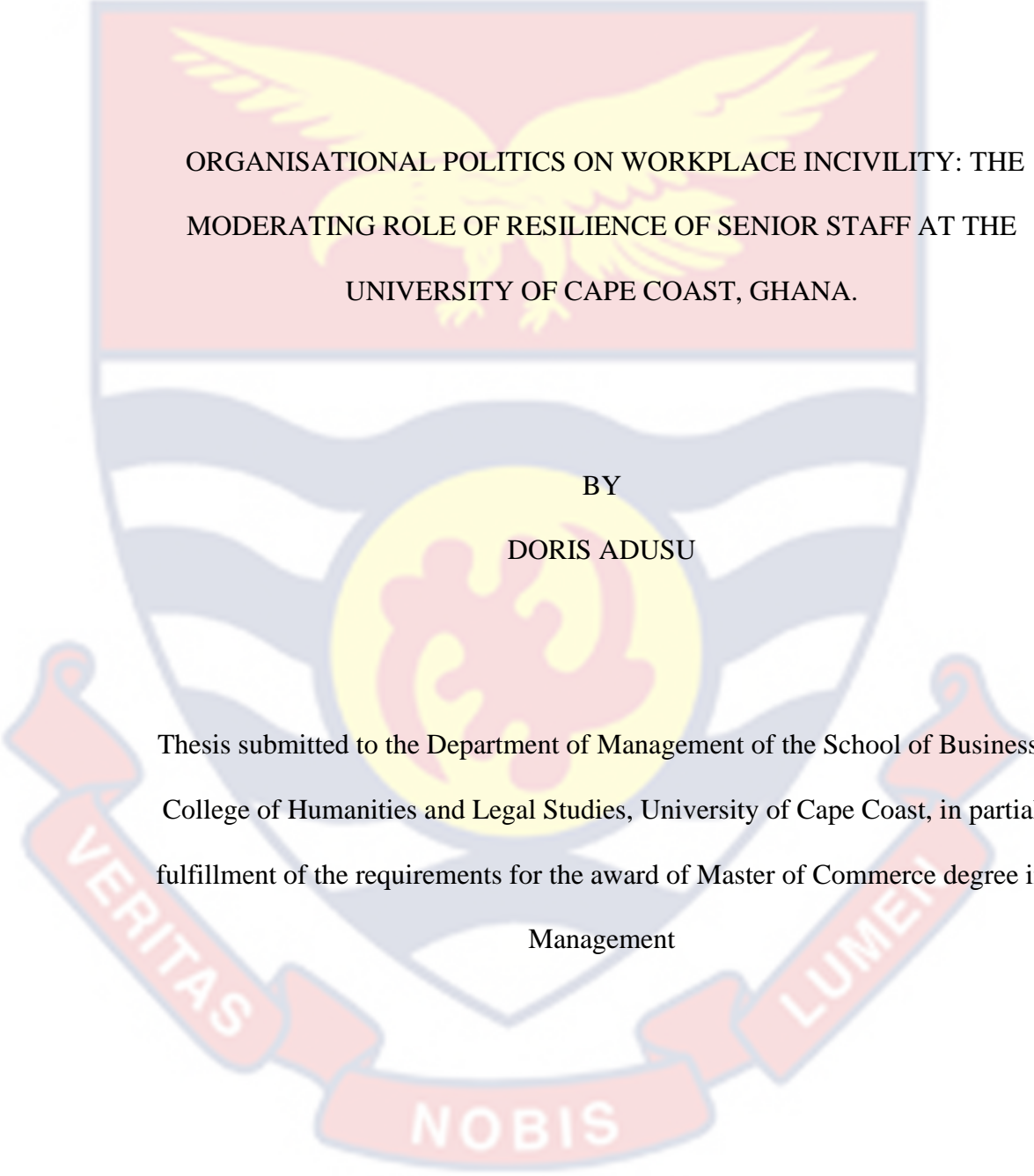

ORGANISATIONAL POLITICS ON WORKPLACE INCIVILITY: THE
MODERATING ROLE OF RESILIENCE OF SENIOR STAFF AT THE
UNIVERSITY OF CAPE COAST, GHANA.

BY
DORIS ADUSU

Thesis submitted to the Department of Management of the School of Business,
College of Humanities and Legal Studies, University of Cape Coast, in partial
fulfillment of the requirements for the award of Master of Commerce degree in
Management

AUGUST 2023

DECLARATION

Candidate's Declaration

I hereby declare that this thesis is the result of my own original research and that no part of it has been presented for another degree in this university or elsewhere.

Candidate's signature:Date.....

Name: Doris Adusu

Supervisor's Declaration

I hereby declare that the preparation and presentation of the thesis were supervised in accordance with the guidelines on the supervision of dissertation laid down by the University.

Supervisor's signature: Date.....

Name: Prof. N. Osei Owusu

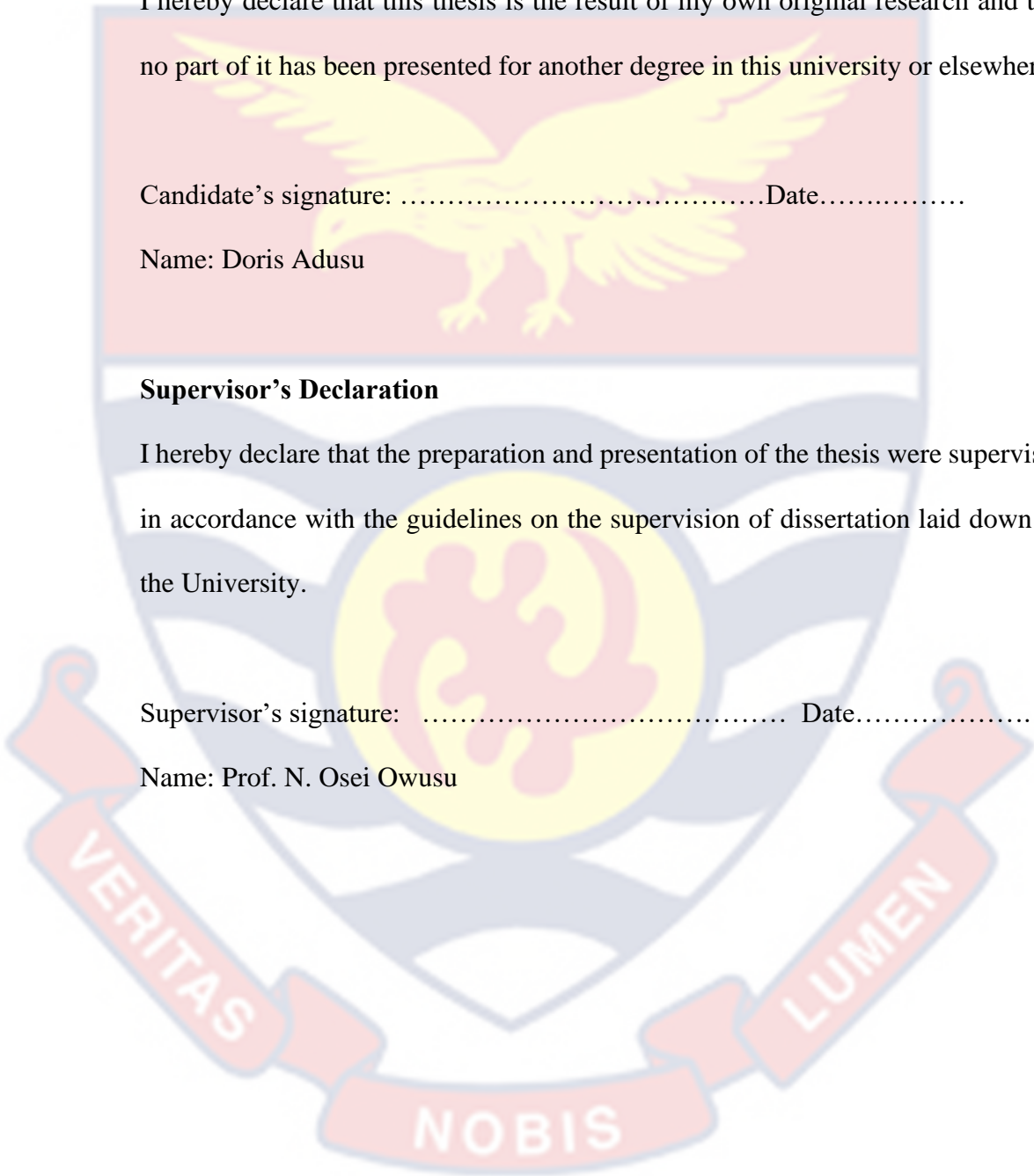

ABSTRACT

The study was conducted to examine the influence of organisational politics on workplace incivility: the moderating role of employee resilience of senior staff at the University of Cape Coast, Ghana. The study used an explanatory research design supported by a quantitative research approach. A total of 310 senior staff were sampled from their population using a simple random sampling procedure, out of which 293 were considered appropriate for analysis. Structured questionnaire is used for primary data collection. The SMART PLS 3 statistics tool were used to analyze the specific research hypotheses. The results of the study concluded that organisational politics are only beneficial to minimize the adverse effect on incivility at the workplace when it is assumed to be healthy, hence, to enhance productivity, performance and growth. The study finally concluded that employee resilience does not moderate the relationship between organisational politics and workplace incivility. The study recommends that, conscious managerial effort needs to be expended to create, maintain and promote a healthy political climate within the organisation that builds the level of performance among senior staff at the University of Cape Coast, resulting in a conducive working environment necessary for organisational growth. The study recommended that, the development of resilience training programmes would advance the awareness of the influence of organisational politics in the development of employee resilience and workplace incivility.

KEYWORDS

Civility

Employee resilience

Organisational politics

Perception of organisational politics

Workplace incivility



ACKNOWLEDGMENTS

My earnest appreciation goes to my supervisor Prof. N. Osei Owusu for this research work from its onset till successful end. His constructive criticisms, corrections and advice are much appreciated. Also, special thanks and appreciation goes to Mr Samuel Opoku, for his generous contribution towards the completion and success of this work.



DEDICATION

To my family



TABLE OF CONTENTS

	Page
DECLARATION	ii
ABSTRACT	iii
KEYWORDS	iv
ACKNOWLEDGMENTS	v
DEDICATION	vi
TABLE OF CONTENTS	vii
LIST OF TABLES	x
LIST OF FIGURES	xi
CHAPTER ONE: INTRODUCTION	
Background of the Study	1
Statement of the Problem	3
Purpose of the Study	5
Research Objectives	5
Research Hypothesis	6
Significance of the Study	6
Limitations of the Study	7
Delimitations of the Study	8
Definition of Terms	9
Organisation of the Study	10
CHAPTER TWO: LITERATURE REVIEW	
Introduction	11

Theoretical Review	11
Deductions from the theoretical review	14
Conceptual Review	15
Empirical Review	32
Conceptual Framework	37
Chapter Summary	38
CHAPTER THREE: RESEARCH METHODS	
Introduction	40
Research Design	40
Research Approach	42
Study Unit	44
Population	45
Sampling Procedure and Sample Size	46
Data Collection Instrument	48
Pre-test	50
Validity and Reliability	50
Data Collection Procedure	51
Response Rate	52
Data Processing and Analysis	53
Structural Equation Modelling	54
Moderation Procedure in SEM	55
Validity and Reliability of the Model	56
Convergent Validity	57

Discriminant Validity	57
Specifying the Structural and Measurement Model	59
Common Method Bias	60
Ethical Consideration	61
Chapter Summary	61
CHAPTER FOUR: RESULTS AND DISCUSSION	
Introduction	63
Descriptive Results for Socio-Demographic Characteristics	63
Findings of the Research Objectives	67
Chapter Summary	84
CHAPTER FIVE: SUMMARY, CONCLUSIONS AND RECOMMENDATIONS	
Introduction	85
Summary of Findings	85
Key Findings of the Study	86
Conclusions	87
Recommendations	89
Suggestions for Further Research	90
REFERENCES	91
APPENDICES	113
APPENDIX B: QUESTIONNAIRE	114

LIST OF TABLES

Table	Page
1 Questionnaire Items and Their Reliability Coefficients	51
2 Response Rate	52
3 Demographic Characteristics for Respondents	64
4 Construct Validity and Reliability	70
5 Structural Model Results for Objective One	71
6 Construct Reliability, Validity and Discriminant Validity	76
7 The Structural Model Results of Objective Two	76
8 Construct Reliability, Validity and Discriminant Validity	81
9 Structural Model Results for Research Objective Three	82



LIST OF FIGURES

Figure		Page
1	Conceptual framework	38
2	Structural Model	60
3	Indicator Loadings Assessment for objective one	69
4	Indicator Loadings Assessment for Objective Two	75
5	Item loadings Assessment for Objective Three	80

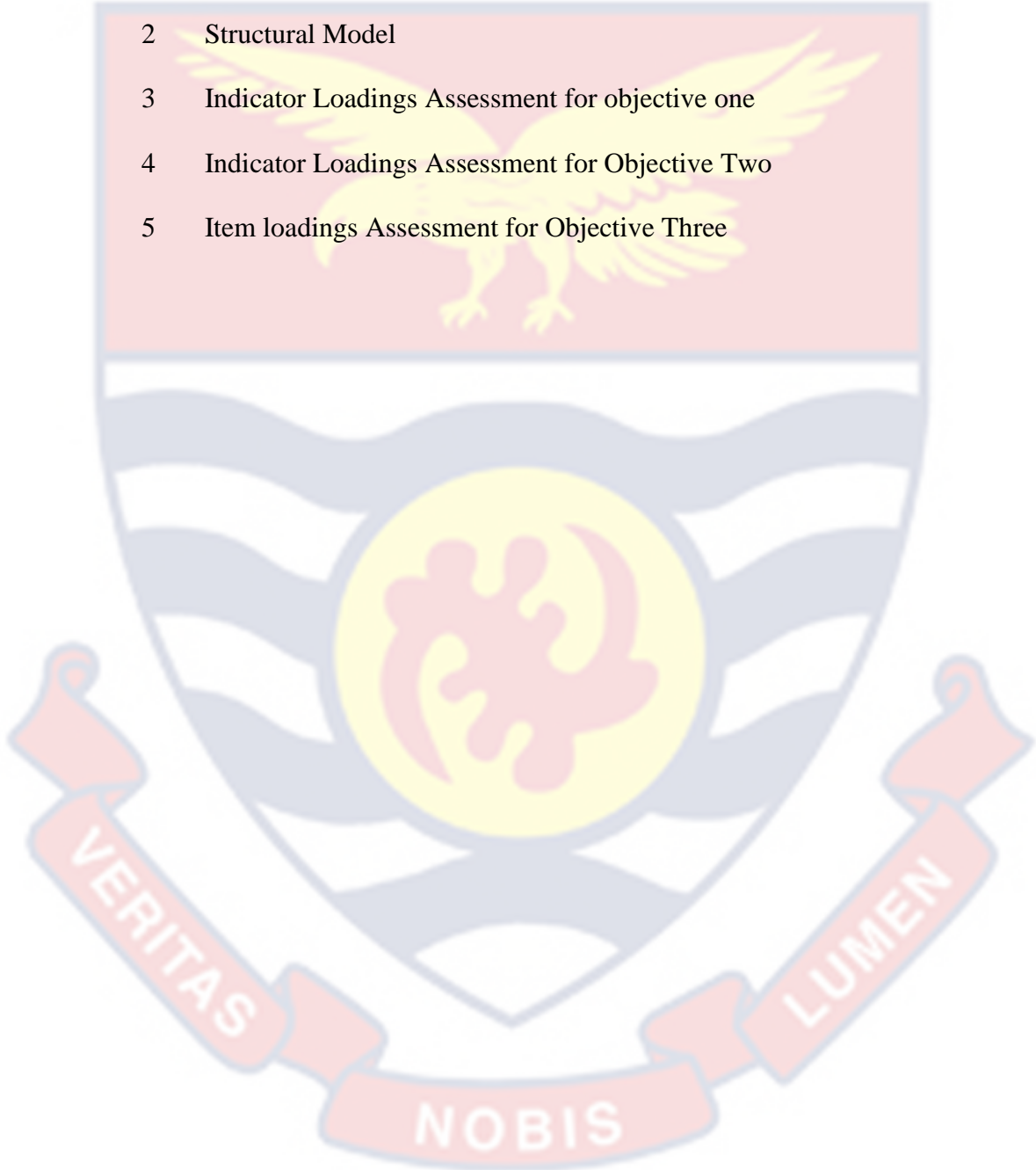

CHAPTER ONE

INTRODUCTION

This chapter presents the overview of the study which includes the background to the study, statement of the problem, the purpose of the study, objectives of the study, hypotheses of the study, significance of the study, delimitation of the study, and organisation of the study.

Background of the Study

Organizational politics has been extensively studied for the past three decades, but there is a need for culture-specific investigations to explore the impact of organizational politics on disruptive behaviours in collectivist cultures. In African countries, including Ghana, which have a collectivist orientation, individuals may experience different levels of exposure to disruptive behaviours such as outbursts, explosive anger, sarcastic comments, and harsh criticisms resulting from organizational politics (Al-Madadha, Al-Adwan & Zakzouk, 2021). In high power distance settings, subordinates may feel a significant power gap due to centralized authority, leading them to engage in political activities within the organization to gain influence (AL-Abrow, 2018). While it is widely acknowledged that politics exists throughout organizations, additional empirical research is needed to fully understand its consequences.

Organizational politics is a reality that managers and employees grapple with, and it significantly impacts organizational operations (Nyikayaramba & Mutimadye, 2014). It involves the deliberate use of power by individuals to satisfy personal interests and goals within the workplace (Bouckenooghe, Zafar & Raja,

2015). Organizational dynamics, such as formal and informal groups, contribute to the prevalence of politics and solidarity within the organization (Strauß & Fleischmann, 2020; Sule, Amuni, Ashiru & Ariyo, 2015).

Understanding workplace incivility requires acknowledging its negative consequences when experienced repeatedly. Multiple incidents of incivility can lead to distress, self-doubt, and even thoughts of leaving the organization (Namin, Øgaard & Røislien, 2021; Cortina, Kabat-Farr, Magley, & Nelson, 2017; Kern & Grandey, 2009). Such incivility may escalate into an "incivility spiral," with colleagues engaging in increasingly aggressive behaviours, ultimately demoralizing the workforce (Vasconcelos, 2020).

Workplace incivility can be as disruptive to employee productivity as harassment or bullying, leading to difficulties in managing tasks and reduced creative problem-solving abilities (Liu, Zhou & Che, 2019). Employees who experience incivility report lower work quality, performance, effort, and commitment (Liu, Zhou & Che, 2019).

Adams' path-goal theory suggests that individuals are motivated by fairness and seek to adjust their input to achieve perceived equity with their reference groups. Organizational politics and affiliations with certain groups can disrupt the input-output ratios, leading to workplace incivility (Samma, Zhao, Rasool, Han & Ali, 2020).

Resilience, the ability to cope with stress and adapt to challenges, influences job satisfaction and problem-solving patterns in employees (Moosavi, 2011). The

presence of resilience among employees affects their attitudes toward work and the demands of high-quality job fields.

According to the Social Exchange Theory (SET), employees engage in incivility at the workplace based on reciprocity principles related to organizational politics (Xerri & Brunetto, 2012; Kheng et al., 2013). This study postulates that employees adopt disruptive behaviours due to their affiliations with political groups within the organization, leading to workplace incivility.

This research is focused on the University of Cape Coast in Ghana, which was established to address the need for highly qualified manpower in education. Senior staff were selected for the study due to the university's emphasis on lecturing and learning, leading to more attention and rewards for senior members and possible segregation among other staff, resulting in incivility. The study aims to examine the influence of organizational politics on workplace incivility, considering the moderating role of employee resilience.

Statement of the Problem

Organizational politics have become highly relevant in today's companies and can be observed in almost every organization (Langley et al., 2021). Understanding organizational politics is important as it sheds light on informal conflict processes and cooperative operations within companies, which in turn influence employee performance (Zhou et al., 2018). Power is the ability to influence others, and the process of influencing individuals is called impact. Employees in an organization strategize their impact, and those with strong political

abilities can effectively utilize their power (Paul, 2018). Politics is essentially about obtaining and utilizing control.

Organizational politics refers to the use of power and influence within organizations. It is considered a phenomenon that is part of the regular social structure of any organization (Rizaev, 2021). Organizational politics can be understood as an individual's observation or interpretation of the self-interested activities of others, such as manipulations of organizational policies. Various studies have categorized organizational politics as actions that govern behaviours and, most importantly, decision-making with power (Khuwaja et al., 2020; Lewandowsky et al., 2020; Mishra & Kodwani, 2019).

Organizational politics is seen as a useful tool that enhances competitiveness in political contexts and competitions, while others view it as problematic. However, it has been shown to be a determining factor in certain antisocial behaviours. Many managers use their power to influence decision-making and actions, which can have detrimental effects on behaviours, organizational cohesion, and performance (Chahar & Hatwal, 2021). These destructive outcomes include a decline in employee happiness and overall engagement, decreased employee performance, increased turnover intentions, and heightened job anxiety or workplace incivility (Alhashedi et al., 2021; Shepherd et al., 2020).

In recent years, organizational scholars have expressed concern about these antisocial behaviours, particularly due to the growing number of disgruntled workers and their impact on the organization and its employees. However, there is

limited research investigating the relatively mild form of psychological unfair treatment characterized by conflicting intentions. Since individuals act based on their perceptions of reality, it is crucial to study employees' perceptions of politics and how it influence job stress and workplace incivility.

This study aims to investigate the aspects of organizational politics and their relationship with employee resilience and workplace incivility among senior staff at the University of Cape Coast in Ghana. Given the demographic advantage, the increasing nature of organizational politics, and its significance in higher education institutions, this research is timely and justified. The goal is to examine the impact of organizational politics on workplace incivility, with employee resilience as a moderating variable.

Purpose of the Study

The purpose of the study is to examine the influence of organisational politics on workplace incivility: the moderating role of resilience of senior staff at the University of Cape Coast, Ghana.

Research Objectives

The specific objectives of the study are to:

1. Assess the influence of organisational politics on workplace incivility.
2. Assess the effect of employee resilience on workplace incivility.
3. Examine the moderating role of employee resilience on organisational politics and workplace incivility nexus among the senior staff of the University of Cape Coast.

Research Hypothesis

Based on the research objectives of the study, the following hypotheses were formulated:

H1: Organisational politics has a positive significant impact on workplace incivility

H2: Employee resilience has a positive significant impact on workplace incivility

H3: Employee resilience does moderate the relationship between organisational politics and workplace incivility

Significance of the Study

The findings of this research will be highly valuable not only to the University of Cape Coast but also to other higher educational institutions. The study will shed light on the impact of organizational politics on workplace incivility and how employee resilience influences this relationship. It will provide valuable insights to the management, especially at the University of Cape Coast, regarding the dimensions of organizational politics and their influence on workplace incivility, enabling them to take constructive measures to achieve the organization's overall goals.

Organizational politics plays a crucial role in the healthy functioning of organizations, as it aims to increase productivity and reduce workplace incivility by promoting task focus, fostering positive employer-employee relations, and improving organizational systems and structures (Elmadag & Ellinger, 2017). However, while research on organizational politics and workplace incivility exists

in various sectors, little attention has been given to the impact of employee resilience on the relationship between these two variables. Therefore, this study holds significant importance.

The results of this study will be instrumental for management in higher education sectors when making strategic decisions related to policy formulation to enhance employee resilience and promote equity. The management at the University of Cape Coast can utilize the study's findings to review existing policies and incorporate mechanisms to mitigate the adverse effects of organizational politics on workplace innovation.

Moreover, this study contributes to the existing knowledge in the field of the impact of organizational politics on workplace incivility by examining the nexus between employee resilience and the relationship between the two variables. The findings will be of immense importance for policy formation within the higher education sector, aimed at improving workplace conditions for employees while considering the presence of organizational politics. Additionally, the study's results will encourage scholars and students to take an interest in researching organizational politics among senior staff and other employees in Ghana.

Limitations of the Study

The main limitation worth noting was the lack of co-operation from respondents for fear of being victimised hindered the study in getting the appropriate information needed for the study. This research encountered several problems especially gathering appropriate data for the analysis. Generally, apathy was the major problem since some of the respondents failed to answer the

questionnaire. The respondents might not have disclosed their actual opinions on certain issues related to the university which could be confidential in nature. Therefore, the bias in their responses was possible. Also, this study researched the influence of organisational politics on workplace incivility at the University of Cape Coast with the views from sampled respondents, which is a small representation of all the employees in the educational sector. This may limit the inferences that can be drawn from this study as their views may not be applied to all senior staff of the universities in Ghana.

Finally, with hindsight, a mixed method (that is, both qualitative and quantitative methods) could have been adopted with more interviews conducted, which would have provided an in-depth understanding of issues. Besides, using the qualitative method would have added to the weight of materials relating to organisational politics, workplace incivility and employee resilience. Although this would have proved extremely time consuming, an interview with the others in higher positions, like the other categories of staff, would also have been useful. This would have helped to understand the rationale behind the elements of organisational politics, workplace incivility and employee resilience.

Delimitations of the Study

The topic under study is “The Influence of Organisational Politics on workplace incivility of senior staff at the University of Cape Coast: the moderating role of employee resilience”. The study is confined to senior staff of University of Cape Coast. Organisational politics is seen in every human institution but the study is confined to only University of Cape Coast and conclusions may only be

applicable to the University of Cape Coast. However, other organisations may adopt the findings of this research.

The study focused on organisational politics, workplace incivility, and employee resilience among senior staff only at the University of Cape Coast, reference to other sectors was only to either buttress a fact or make a comparison. Its scope was restricted to the University of Cape Coast. The main respondents for the study were senior staff at the University of Cape Coast. In terms of content, there is countless number of issues that could have been looked at in terms of organisational politics, workplace incivility, and employee resilience.

Definition of Terms

Organisational Politics: An informal, unofficial, and sometimes behind-the-scenes efforts to sell ideas, influence an organisation, increase power, or achieve other targeted objectives (Brandon & Seldman, 2004; Hochwarter, Witt, & Kacmar, 2000).

Workplace Incivility: It refers to low intensity deviant behaviour with ambiguous intent to harm the target, in violation of workplace norms for mutual respect (Reio, 2013).

Employee Resilience: Rego et al. (2017) stated that resilience should be regarded as an important competitive advantage beyond social and economic resources in organisations. This is because contemporary workplaces are often uncertain, stressful and dynamic environments, facing challenges such as conflict, difficult circumstances, setbacks, failures, and high expectations. How employees manage to make the most out of these bad situations and what prevents them from feeling

personally affected when things don't go the way they want or expect is crucial to organisational adaptability.

Organisation of the Study

The study was made up of five chapters. Chapter One looked at the background of the study, statement of the problem, research objectives, research questions and significance of the study, limitations, scope of the study and organisation of the study. Chapter Two reviewed the literature available on stress and job performance, particularly on the employees in the organisation. It investigated organisational politics and its' influence on workplace incivility in the workplace using literature from books and other studies relating to the topic. Chapter Three described the methodology that would be used in the study: this included the population size, sample size and sampling techniques as well as methods of data collection and data analysis. Chapter Four will present the data analysis and the findings based on research questions. Chapter Five will provide an interpretation of the results based on the findings and provide recommendations for further studies to be conducted.

CHAPTER TWO

LITERATURE REVIEW

Introduction

This chapter provides a review of the theoretical and the empirical framework on organisational politics, workplace incivility and employee resilience. The review also shows how these constructs relate in an educational sector setting. The write-up of the chapter will begin with review of theories underpinning the study, before addressing conceptual and empirical issues of organisational politics, workplace incivility and employee's resilience.

Theoretical Review

Organisational politics appears to be an undesirable, yet unavoidable reality of organisational life (Asrar-ul-Haq et al., 2019). Corollary, the complex nature of it within the educational sector demands an approach that emanates from multiple behavioural perspectives as this will be ideal for achieving reduced form of rudeness, ignoring others, abuse of relationship among employees. As such, the social exchange theory thence establishes the relationship among organisational politics, workplace incivility and employee resilience.

Social exchange theory

Social Exchange Theory argues that relationships at work evolve over time into trusting, loyalty, and mutual commitments, if all parties involved abide by reciprocity or repayment rules. It implies that social behaviour is the result of an exchange process (Soieb, Othman & D'Silva, 2013). This is important in determining behaviour demonstrated by employees within the organisation. The

main reason for this exchange is to maximize benefits and minimize costs (Soieb et al. 2013). The theory has been used in many fields, especially in investigating the need for resilience on the part of employees with respect to certain conditions within the organisation (Kheng et al. 2013; Zhang, Zheng & Darko, 2018).

The social exchange theory is relevant to this study because the theory is characterized by perceived equality which imply the presence of reciprocity. Based on social exchange theory, because feelings of obligation to support through politics are expected to be created, we might expect high perceived organisational conditions and environment, to lower workplace incivility on the part of employees. Researchers have argued that individual who perceives greater organisational conditions and support from their employing organisation would be more likely to feel obligated to “repay” the organisation irrespective of perceived incivility (Eisenberger et al., 1986, 1990).

One way for an individual to repay the organisation is through continued participation. Eisenberger et al. (1990) argued that perceptions of conducive working conditions and support would encourage the adoption of organisational membership as an important part of an employee’s self-identity. Thus, individuals perceiving greater support would be less likely to seek alternate employment or to leave the organisation. Indeed, all social life needs a degree of reciprocity on the part of actors in social situations. Thus, when individuals see that there are relatively balancing levels of reciprocity in a social exchange, they are more likely to be satisfied in that exchange. Social exchange theory concludes that individuals who perceive the presence of reciprocity in their social relationships are likely to

feel more satisfied with and maintain those relationships in their respective organisations. Social exchange theory is an evolving conceptual framework that can be used to explain the concept of organisational politics, workplace incivility and employee resilience.

According to SET, people engage in a series of reciprocal transactions with each other through which social exchange ties are built and nurtured (Shim, 2010). However, organisational politics causes inequality which tends to disrupt the trade ties (Chinomona & Mofokeng, 2016). A politicized work environment is typified by self-serving acts and decision-making practices which regularly diverge from official norms, procedures, and structures (Li et al., 2020). Subsequently, organisational politics naturally leads to a stronger feeling of distrust, disagreements, misunderstanding, and negative sentiment towards others, consequently damaging social exchange connection among the employees (Karim, 2021; Karim et al., 2021).

In this study, it is postulated that based on the SET, employers adopt specific approaches to handling and dealing with politics at the workplace, geared towards creating an organisational environment which in turn stimulates, improved civility among employees based on the reciprocity principle (Gouldner, 1960). This theory, therefore, implies that employees will increase their loyalty, engagement, and work performance since they are obliged to return the act of kindness that they have received (Aselage & Eisenberger, 2003). Hence, the above descriptions depict that when employees are given more innovation-relevant resources, the more trust and fairness will be perceived by them exist in the organisation. This will, in turn, make

the employees obliged to take on the extra role behaviour (Organ, 1988) which is important in seeding improved civility and behaviour among the employees.

Deductions from the theoretical review

From the perspective of social exchange theory (SET), Thompson et al. (2018) showed that exchange relationship can serve as the important determinant of uncivil behaviours in the workplace. According to SET, people engage in a series of reciprocal exchanges with each other through which social exchange relationships are developed and sustained (Shim, 2010). However, organisational politics promotes unfairness which tends to undermine the exchange relationships (Chinomona & Mofokeng, 2016). A politicized work environment is marked by self-serving activities and decision-making practices which often deviate from formal policies, procedures, and structures (Li et al., 2020).

Individuals engaging in organisational politics usually manipulate organisational processes (e.g., decision-making, rewards and promotion) for personal gain at the expense of well-being of others and the organisation (Basar & Basim, 2016). Consequently, organisational politics inevitably brings about a greater sense of distrust, conflicts, misunderstanding, and negative feeling towards others, thereby damaging social exchange relationship among the employees (Karim, 2021; Karim et al., 2021). The poor social exchanges can stimulate counterproductive behaviour (Wang et al., 2019), particularly workplace incivility (Itzkovich & Heilbrunn, 2016).

Moreover, Torkelson et al. (2016), based on social power theory, showed that power position plays a key role in instigating uncivil behaviours and described

incivility as a means of exercising power. Thus, those who are politically powerful are likely to perform uncivil behaviours with less powerful employees. As a spillover effect, those who are victims may reciprocate incivility following the principle 'tit for tat', as described by Andersson and Pearson (1999). Thus, workplace's political environment is likely to be a strong determinant of employees' uncivil behaviours.

Conceptual Review

This section seeks to provide an extensive discussion and enhanced knowledge with respect to the constructs used in this study. How the various concepts are operationalized in literature will be addressed. Organisational politics will initially be addressed followed by a discussion of the dimensions of organisational politics. In addition, workplace incivility will be addressed with an emphasis on the context of the higher educational institution. Finally, employee resilience will also be discussed.

Organisational Politics

Organizational politics is often seen as an undesirable but inevitable aspect of organizational life (Asrar-ul-Haq et al., 2019). It is generally defined as a set of employee behaviours aimed at securing self-interests without considering the well-being of the organization and its members (Kacmar & Baron, 1999). These behaviours may include forming power coalitions, associating with influential allies, exchanging favors, pressurizing or blaming others, using flattery and ingratiation, manipulating information, managing impressions, and engaging with influential individuals (Basar & Basim, 2016; Turabik & Baskan, 2020). Such

activities are often perceived by organizational members as self-serving, unfair, and unjust (Basar & Basim, 2016), and can lead to various negative outcomes for employees, such as job stress, turnover intention, job dissatisfaction, reduced work engagement, and lower levels of organizational citizenship behaviour (Asrar-ul-Haq et al., 2019; Chhabra, 2021; Chinelato et al., 2020). Additionally, literature suggests that organizational politics significantly contributes to hostility, workplace deviance, counterproductive work behaviour, and incivility among organizational members (Arogundade et al., 2016; Bashir et al., 2019; Crawford et al., 2019; Karim et al., 2021; Meisler et al., 2019).

Perceived organizational politics refers to an individual's observation or interpretation of others' self-interested behaviours, including the careful manipulation of organizational policies (Ferris & Kacmar, 1992). Politics is considered a phenomenon that is part of the regular social fabric of any organization (Abbas & Raja, 2014; Vigoda & Cohen, 2002; Yilmaz, 2014). Some argue that politics can be functional, as political environments and competitions can enhance productivity (Pfeffer, 1981). On the other hand, others view organizational politics as dysfunctional (Cropanzano, Howes, Grandey, & Toth, 1997). Nevertheless, it has been found to play a crucial role in determining some antisocial behaviours.

The prevalence of interpersonal mistreatment and antisocial behaviours in the workplace is on the rise, which has garnered attention from organizational and social researchers. While much research has been conducted on antisocial behaviours like workplace aggression, bullying, harassment, and tyranny, less attention has been given to milder forms of mistreatment, such as workplace

incivility. However, a survey study found that up to 90% of respondents considered incivility a serious problem due to its unnoticed prevalence (Andersson & Pearson, 1999).

Organizational politics can be categorized into three sub-categories: general political behaviour (GPB), go along to get ahead (GATGA), and politicized reward and promotion (PRP) (Kacmar & Carlson, 1997). PRP is used instead of pay and promotion (PAP) in the context of public universities in Bangladesh, where academic members' financial payments are determined outside the university's authority due to adherence to the government pay scale. GPB represents self-serving behaviours for gaining desired outcomes, GATGA involves being passive and silent to politickers to secure self-interests or valued outcomes, while PRP relates to political behaviours concerning rewards and promotions through the manipulation of organizational policies (Kacmar & Carlson, 1997; Yilmaz et al., 2014).

Despite organizational politics being often associated with negative consequences, it is not always about power manipulation, trust issues, and hidden agendas. Positive organizational politics can exist, benefiting more than just a politically-skilled minority (Vredenburg & Shea-VanFossen, 2010). Studies show that individuals with different personalities may perceive politics more positively than others (Rosen et al. in Vigoda-Gadot & Drory, 2006). Positive organizational politics can foster a competitive advantage, especially when individuals are politically trained and can manage organizational environments under stress (Drory & Vigoda-Gadot, 2010; Gotsis & Kortezi, 2010). It can lead to trust, collaboration,

and organizational equality. Furthermore, positive political behaviour may enhance learning, flexibility, and innovativeness within organizational structures (Coopey & Burgoyne, 2000; Engeström, 2001; Vigoda-Gadot & Kapun, 2005). Good politics can be associated with achieving strategic goals, promoting collaboration, and maintaining ethical balance (Kurchner-Hawkins and Miller in Vigoda-Gadot & Drory, 2006).

In conclusion, organizational politics is a multifaceted aspect of organizational life that can lead to both negative and positive outcomes. While it can be associated with undesirable behaviours and mistreatment, it can also serve as a mechanism for resolving disputes and fostering learning and collaboration within an organization. Positive political behaviour, when managed effectively, can contribute to a harmonious and innovative work environment.

The Negative side of Organisational Politics

While organizational politics is often considered to have positive potential, research indicates that people predominantly view it as negative (Drory & Vigoda-Gadot, 2010; Othman, 2008; Poon, 2003). A famous quote by Block (1988) illustrates this sentiment: "If I told you that you were a highly political person, you would either take it as an insult or at best as a mixed blessing." As a result, political work environments are generally perceived negatively by individuals, generating feelings of unfairness, deprivation, and inequity (Gotsis & Kortezi, 2010; Harris et al., 2009; Ladebo, 2006; Vigoda-Gadot & Kapun, 2005). Consequently, employees who perceive their organization as being politicized are likely to withhold useful information (Beugré & Liverpool in Vigoda-Gadot & Drory, 2006).

Organizational politics may stifle and distort the voices and opinions of individuals, leading to defense mechanisms and increased uncertainty (Vince, 2001). Within political contexts, employees may feel threatened by uncertainty, ambiguity, and self-interest behaviours exhibited by others (Harris et al., 2009). Genetic dispositions such as forcefulness, power and control demand, manipulation, rank competition, and egotism may arise in response to common organizational conditions of uncertainty, resource shortage, and conflict (Vredenburg & Shea-VanFossen, 2010). Studies have found that organizational politics have a negative impact on work performance and organizational commitment, especially among lower-status employees (Drory, 1993; Ferris et al., 1989; Gotsis & Kortezi, 2010; Vigoda-Gadot & Kapun, 2005).

Others believe that organizational politics are a source of workplace stress and conflict (Ladebo, 2006; Vigoda-Gadot & Kapun, 2005). Research by Cropanzano and Li (in Vigoda-Gadot & Drory, 2006) and Ferris et al. (1993) found a strong link between politics and job anxiety, particularly for individuals with lower perceived control. Consequently, organizational politics may lead individuals to mentally or physically detach from their job, causing a lack of focus and concentration (Vigoda-Gadot & Kapun, 2005).

The assumption that organizational politics promotes self-interest behaviour has led to a negative view of workplace politics, which persists among individuals (Vigoda-Gadot, 2007). Some argue that political behaviour hampers information exchange and communication (Curtis, 2003; Poon, 2003), thus inhibiting learning.

Communication and information management are vital in political practices within organizations (Kurchner-Hawkins and Miller in Vigoda-Gadot & Drory, 2006).

Organizational politics is associated with cultural factors that may inhibit learning.

Cultures emphasizing the development and hoarding of technical abilities used independently by individuals are less likely to foster knowledge-sharing networks (Bishop et al., 2006). Additionally, cultures lacking trust are unlikely to facilitate knowledge transmission from individuals to groups or organizations (Bishop et al., 2006). Low trust climates may result in informal highly politicized behaviour. Trust is closely linked to organizational politics, impacting individuals' behaviour as they may be distrustful of others' motives in a low-trust climate (Othman, 2008; Poon, 2003; Zaleznik, 1971). This can lead to an environment of informal politicking.

Furthermore, a political atmosphere may have negative consequences even for individuals not directly impacted by the primary political actions (Vigoda, 2002).

Highly political individuals tend to possess traits like Machiavellianism, being logical rather than empathetic, manipulating and deceiving to achieve personal aims (Rosen et al., in Vigoda-Gadot & Drory, 2006). Organizations may become impaired by such organizational politics, often referred to as "workplace toxins" (Chircop, 2008). Leaders with an understanding of and competence in handling workplace politics are essential to address these issues.

Dimensions of Organisational Politics

According to Vredenburg and Shea-VanFossen (2010), some research has identified organisational conditions that cause employees to interact in workplace political behaviours, they argue that the origins of individual

attributes and therefore the nature of their interactions with organisational conditions that foster political strategies in work organisations come from the evolution of an individual's hereditary genetic structure. Power or politics grows tangibly and non-tangible whilst individuals compete for neck to neck upon each other.

Limited Resources: The degree of politics, criticality, and scarcity of resources within an organisation are directly related. Politics surfaces when the resources are declining and their existing pattern is changing. Infusion of latest and unclaimed resources will cause high political behaviour. If resources were abundant, then all the varied constituencies within the organisation could satisfy their goals. But because they are limited, not everyone's interest is often provided for. Further, whether true or not, gains by individuals or groups are often perceived as being at the expense of others within the organisation. (Huntington, 1964). Not surprisingly, when organisations set budgets to drive down costs and end prices to the customer, there is enormous pressure to carry down expenditure and investment.

Power: According to Vigoda-Gadot (2003), an individual has power if they exert control over the allocation of resources and if they are in position to form and enforce decisions. Power therefore can exist formally and informally at every level within an organisation. It is been widely recognised that both politics and power are a big part of human behaviour as they affect the power to secure one's goals and interests in a social system (Vigoda-Gadot, 2003). Daft (2007), also asserted that the utilization of power in organisations however

requires both skill and willingness. Many choices are made through political processes because rational decision processes do not fit. Uncertainty or disagreement is just too high.

Political tactics for using power to influence decision outcomes include build coalitions and expanding networks, assign loyal people to key positions, control decision premises, enhance legitimacy and expertise, make an immediate appeal, and use of power however should be obvious. Individuals in positions of greater formal responsibility are often both politically active within an organisation and therefore the subject of political activity themselves within the organisation. They need a tendency to be politically active because they have something useful to trade, better exchange, namely resource allocation, and deciding and in fact it's for these same reasons that they are the topic of political maneuverings initiated by others.

The right use of this type of organisational power may be a huge test of a leader's authenticity (Buchanan & Badham, 2020). Organisations have power structures that compete amongst themselves. Different coalitions are formed in organisations between people that think alike within the organisation. These coalitions then therefore compete for power which lead to organisational politics.

Gender Perceptions: Affirmative action has constantly been used as a tool to address the imbalance between males and females at the work place, with political aids and legal frameworks being reinforced to bring parity. Generally, men have dominated work place more than women, mainly in positions of significance.

However, according to research by Burke (2007), women are argued to have the same possibilities as men to advance up the corporate ladder, particularly if women are entering the same occupations and are similar to men in ambitions and abilities.

Women are assumed to have successful careers by following the male model and by sharing child and home responsibilities with their partner. The politics of gender has dominated academic debate since time immemorial not only in the workplace but also in main stream politics.

Information Power: Information control, distribution and manipulation are genres of information power and in some instances it can be veiled as Expertise game. According to Cacciattolo (2013) Expertise Game is played when an employee hoards information for himself because of some hidden agenda. She argues that this experience enhanced the participant's rapport with colleagues and subordinates whilst learning informally from them. On the other side of the continuum this political game appeared to promote a sense of frustration, stress, demotivation to learn, and he also considered leaving the job. This supports Ladebo's (2006) and Vigoda-Gadot & Kapun's (2005) proposition that organisational politics are a source of stress at the place of work (Cacciattolo, 2013).

Information is defined as processed or meaningful data about the world we work within. In this sense, any observation may be considered data and once processed and made meaningful to a recipient it is then defined to be information. Access to information is very important for the feeling of being involved by employees within the organisation. Organisations are entities, which process

information. Decision making is largely a process of information as (Cheney et al., 2004) present. This means that the organisation itself can be seen as bits of information that are moving forward in organisation. Gathering more information and sending it forward in an organisation creates the work of information processing (Mykkänen, 2010). The flow of information makes the environment for decision making for individuals and groups.

The amount of information in this flow affects how successful the decision making in the end is. Cheney et al. (2010) also point out that when individuals cannot process large amounts of information; organisations tend to gather more and more information through for example surveys and forecasting. Organisations do collect and distribute information to enhance its efficiency and, in the process, this information might be distorted which may be intentional or accidental for instance, sometimes employees are asked to summarize data and report it to their supervisors. By definition, summarizing data means leaving some parts of it out.

Management Decision Making: Zeleny (2012) defined decision-making as a dynamic process. That is, a complex search for information, full of deviations, enriched by feedback from casting about in all directions, gathering and disregarding information, fueled by fluctuating uncertainty, indistinct and conflicting concepts- some sharp, some hazy; the process is an organic unity of both pre-decision and post-decision stages overlapping within the region of partial decision-making. Decision making may be defined as the process of making choices from among alternatives (March, 2010). Management theorists come to an agreement that decision making is one of the most important if not the most

important of all management activities (Drucker, 2010). It is important to note, however, that not only managers make decisions in organisations, but also employees at every level in an organisation participate in decision making as well.

The late management consultant explains that most discussions of decision making assume that only senior executives make decisions. This is a dangerous mistake since making sound decisions is a crucial skill at every level in the organisation (Drucker, 2009). Management theorists agree that decision making is one of the most important if not the most important of all management activities (Drucker, 2010). He further elaborated that, not only managers make decisions in organisations, but also employees at every level in an organisation participate in decision making as well. However, some institutions today, many decisions are made by the top management while employees are left out (Bonito, 2012).

Schermerhorn et al. (2011) listed some benefits of incorporating employees in decision making. These include; more knowledge and expertise are available to solve the problem, a greater number of alternatives are examined, the final decision is better understood and accepted by all employees, and there is more commitment among all employees to make the final decision work. Jahansoozi (2005) believes that transparency in decision-making is required for public trust. Offering promotions and benefits are critical for organisations to have a transparent system. When organisations practice transparency in decision making, morale and loyalty increases and as a result subordinates are retained for a longer period of time. The style of Decision Making in an organisation is influenced predominantly by the culture of an organisation as well as the personality of the decision makers.

Workplace Incivility

Workplace incivility is a relatively new concept in fields like management, education, and healthcare, representing various forms of antisocial behaviour. It encompasses a range of disrespectful and rude actions, from minor breaches of basic etiquette to more severe professional misbehaviour, leading to moral deterioration (Carter, 1998; Gladwell, 1996; Johnson, 1988; Martin, 1996; Roberts, 1985). According to the Random House Dictionary, incivility is described as "uncivil conduct or treatment," and being uncivil is defined as "rude, unpleasant, and discourteous" (Dictionary).

Workplace incivility, in particular, refers to deviant behaviour in organizations that violates norms of mutual respect (Huang et al., 2021). It involves seemingly insignificant behaviours that are rude, disrespectful, discourteous, or insensitive, with ambiguous intent to harm (Bar-David, 2018). These behaviours can include showing disrespect towards co-workers, using derogatory terms, or making demeaning comments (Huang et al., 2021). Workplace incivility is characterized by three elements: low intensity (minor workplace deviance excluding physical violence), violation of norms for mutual respect, and unclear intentionality of the instigator's behaviour (Zhou et al., 2019).

Experiencing workplace incivility is associated with various negative consequences for both individuals and organizations. These consequences include emotional exhaustion, burnout, turnover, job dissatisfaction, reduced work engagement, instigated workplace incivility, knowledge hiding, lower organizational commitment, reduced organizational citizenship behaviour, counterproductive behaviour, and lower job performance (Alola et al., 2021; Chen

& Wang, 2019; Liu et al., 2019; Loh & Loi, 2018; Mao et al., 2019; Reio & Trudel, 2013; Salman et al., 2020; Tricahyadinata et al., 2020; Wang & Chen, 2020).

Incivility, which involves rudeness and disrespect for others, violates rules of respect in interpersonal connections (Morris, 1996; Brown & Levinson, 1987). Scholars have described incivility as "low-level infractions of community standards that signify a deterioration of traditionally accepted norms and values" (LaGrange, Ferraro, & Supancic, 1992). Incivilities are often noticed and civil behaviours are barely recognized (Brown & Levinson, 1987; Sapir, 1927).

Workplace incivility is low-intensity deviant behaviour with unclear intent to harm the target, violating workplace standards for mutual respect (Andersson & Pearson, 1999). The ambiguous intent of incivility can cause stress for the victim, as the purpose behind the uncivil behaviour is unclear. Despite being of lower severity compared to other hostile behaviours, incivility has the potential to lead to hostility and escalating confrontations (Lim et al., 2008).

Incivility differs from psychological aggression in that it lacks clear, purposeful intent. It can often be attributed to factors like the instigator's ignorance or personality, making the intentionality of the behaviour unclear to one or more parties involved (Andersson & Pearson, 1999; Pearson et al., 2001). Workplace incivility should be distinguished from physical aggression and violence (VandenBos & Bulatao, 1996).

Workplace incivility can trigger a cycle of negative organizational behaviour, leading to more severe staff misconduct and hostility over time (Anderson & Pearson, 1999). Minor interpersonal mistreatment can accumulate

and eventually result in major organizational conflicts. Despite being low intensity, workplace incivility can have a significant impact, damaging the work atmosphere and causing discomfort and tension among employees (Vickers, 2006).

Forms of Incivility

Workplace incivility, the main focus of this research review, encompasses a wide range of misbehaviours within the workplace setting. According to Trudel (2011), uncivil behaviours can include making disdainful comments, writing undignified notes or emails, disrupting meetings, chastising someone publicly, gossiping, giving the silent treatment, failing to give proper credit, sexually harassing employees, rolling eyes, and yelling at others. It also involves excluding someone from a meeting, neglecting to greet someone, interrupting people while they are speaking, leaving a jammed photocopier for others to fix, creating a mess in the kitchen, eavesdropping on others' phone calls, ignoring colleagues' requests, using disparaging language or tone, and making inflammatory remarks.

Brehm and Brehm (1981) categorized workplace incivility into two main groups: co-worker incivility and supervisor incivility. Co-worker incivilities are uncivil behaviours carried out by individual co-workers, such as cruel comments, "snippy" emails, gossip, and shunning. On the other hand, supervisor incivility includes many of the same types of uncivil behaviours, but they come from the supervisor. Experiencing uncivil treatment from supervisors can be particularly distressing due to their power to control behaviour in the organization, leading to feelings of autonomy loss and unfairness. These factors have the potential to result

in worker dissatisfaction, anger, anxiety, and corresponding behavioural reactions (Fox & Spector, 1999; Hershcovis & Barling, 2010).

It is important to note that incivility is not limited to verbal abuse; it can also manifest through nonverbal means. Disrespectful nonverbal behaviours can include staring, ignoring, or excluding coworkers (Lim, Cortina, & Magley, 2008). Leaving a jammed printer, gossiping, snapping at co-workers, and not turning off mobile phones during meetings are also examples of uncivil actions in the workplace (Johnson & Indvik, 2001). Due to its low intensity, incivility can easily be overlooked and ignored, allowing it to escalate into more serious forms of workplace harassment if not addressed.

Martin (1996) provided additional examples of workplace incivility, such as answering the phone with a curt "yeah," using voice mail to screen calls, leaving a half cup of coffee for others to brew, standing impatiently at someone's desk while they are on a phone call, leaving trash on the floor for others to clean, and talking loudly on the phone about personal matters. As professional interactions become more complex, discourteous behaviour becomes more nuanced. There are many ways for individuals to show disrespect towards others (Carter, 1998; Marks, 1996; Neuman & Baron, 1997).

While workplace incivility may overlap with other forms of organizational mistreatment, it is distinct in its characteristics. Workplace mistreatment has been described in various conceptual forms, such as aggressive, violent, harassing, physically abusive, tyrannical, deviant, and antisocial behaviours. Some of these categories involve more extreme abuse with clear intent to harm, while others

encompass less acute forms with uncertain intent. Workplace incivility shares similarities with aspects of petty tyranny, which refers to a leader's lack of consideration towards others without clear intent to harm. It also intersects with concepts of employee deviance and antisocial employee conduct, which involve intentional breaches of organizational standards that harm the well-being of the organization, its members, or both. Incivility, being one form of workplace mistreatment, contributes to a wider spectrum of negative behaviours within organizations.

Causes of Workplace Incivility

The costs of incivility, both direct and indirect, can be substantial for a community or culture. In workplaces, as well as in the wider community, incivility has become a growing concern due to its frequent occurrence. Baron and Neuman (1996) and Johnson and Indvik (2001) highlight that organizational changes have contributed to the rise of workplace incivility. These changes, such as downsizing or increased workplace diversity, have accelerated the spread of incivility. Johnson and Indvik (2001) conducted meticulous research to identify the causes of workplace incivility, revealing factors like anger, stress, lack of communication, increased workloads, job insecurity, organizational changes, and poor work organization.

Similar findings were reported in the studies of Pearson, Andersson, and Porath (2000). Participants mentioned that heavy work responsibilities leave little time for courtesy toward co-workers, colleagues, and subordinates. Re-engineering, downsizing, budget cutbacks, and pressure for productivity have led to increased

workloads and reduced resources, fostering a culture of incivility. The rise in part-time and temporary workers is also considered a possible contributor to uncivil workplace behaviours.

Furthermore, participants noted that the increased employment of part-time and temporary employees weakens their connections to the organization, thereby fostering workplace rudeness and incivility. Changes in organizational structure, such as flattened hierarchies for faster decision-making, have contributed to a too casual environment, eroding normal corporate etiquette and promoting disrespect among employees. As these organizational changes are becoming more common, it is expected that more organizations will experience varying degrees of incivility.

Trudel (2011) identified certain situations that may contribute to the manifestation of incivility, such as budget cutbacks, management changes, staff reduction, and increased surveillance of personnel. The prevalent use of email and phone communication has also made uncivil acts more feasible. Informal groups with unclear behavioural boundaries may perpetuate uncivil practices. These workplaces are characterized by casual dress, open expression of emotions, and a lack of control in interpersonal relationships.

Uncivil behaviours can be both the cause and consequence of conflict incidents. How individuals respond to uncivil behaviours largely determines whether similar actions escalate in future interactions. The prevalence and intensity of workplace incivility are influenced, in part, by individual reactions to perceived negative acts. Trudel and Reio (2011) discovered that individuals who employ a more balanced style of conflict management are less likely to engage in uncivil

behaviours and also less likely to be targets of incivility. On the other hand, those with a more assertive or aggressive conflict management style are more prone to engaging in uncivil behaviours and being targets of uncivil actions.

Empirical Review

The empirical review was developed in line with the specific objectives of the study. The contributions of organisational politics and employee resilience on workplace incivility have been acknowledged in literature.

Poon (2003), developed a model of perceptions of organisational politics and tested using a sample of 208 Malaysian employees from diverse occupations and organisations. The results of their path analysis on the survey data showed that job ambiguity, scarcity of resources, and trust climate were significant predictors of perceptions of organisational politics. Also, perceptions of organisational politics, in turn, mediated the effects of these situational antecedents on job stress, job satisfaction, and turnover intention. Specifically, employees who perceived a high level of politics in their workplace reported higher levels of stress, lower levels of job satisfaction, and higher levels of intention to quit than did employees who perceived a low level of politics.

Also, Pearson and Porath (2005) conducted research on the nature, consequences and remedies of workplace incivility: No time for “nice”? Think again. It was revealed by their studies that, incivility, or employees' lack of regard for one another, is costly to organisations in subtle and pervasive ways. Although uncivil behaviours occur commonly, many organisations fail to recognize them, few understand their harmful effects, and most managers and executives are ill-

equipped to deal with them. As a result, over the years, through interviews, focus groups, questionnaires, experiments, and executive forums with more than 2,400 people across the U.S. and Canada, they found that incivility causes its targets, witnesses, and additional stakeholders to act in ways that erode organisational values and deplete organisational resources. Because of their experiences of workplace incivility, employees decrease work effort, time on the job, productivity, and performance. Where incivility is not curtailed, job satisfaction and organisational loyalty diminish as well. Some employees leave their jobs solely because of the impact of this subtle form of deviance. Most of these consequences occur without organisational awareness.

Vigoda-Gadot and Kapun (2005), in their research suggested a theoretical model and empirical examination of the relationship between organisational politics and perceived employees' performance across two separate settings: the private sector and the public sector. 700 employees of private sector and public sector organisations provided data on perceptions of organisational politics, job satisfaction, organisational commitment, job distress and burnout, as well as self-reported turnover intentions, negligent behaviour and absenteeism. Their findings indicated that politics perceptions differ substantially across sectors and prove higher in the public than in the private sector. The theoretical model was tested using an SEM technique and was found valid in both sectors. However, when closely analysed, the same model still fits private sector organisations better than public sector ones.

Yilmaz (2014) sought to examine the probable effects of perception of politics on impression management behaviours of hotel employees in Izmir, Turkey. A total number of 205 usable questionnaires were collected from employees working in five-star hotels in Izmir city center. The hypothesized relationships were tested using SPSS 17 version. The results indicated that organisational politics perception of employees was an important determinant of impression management behaviours. Their research made useful contributions to the current knowledge base by investigating the direct effect of perception of organisational politics on impression management behaviours since it is predicted that politics perception of employees has potential to paralyze the organisational climate and can affect the relationship both between employees and between employees and managers.

Arogundade, Arogundade and Gbabijo (2016) in their study examined the influence of perceived organisational politics on workplace incivility. A total of 400 participants were randomly selected from private and public organisations in Ogun State, Nigeria. A battery of psychological instruments was used in the collection of data for this study which include: Workplace Incivility Scale and Perception of Organisational Politics Scale. Descriptive statistical methods, Pearson's product moment correlation and Independent Sample t-tests were used to analyse data in order to test the five hypotheses formulated. Their findings showed that perceived organisational politics had a significant influence on workplace incivility. This implies that, the lower the level of perception of organisational politics, the lower the report of incivility and vice versa

.Furthermore, a significant positive relationship existed between perceived organisational politics and workplace incivility. It also revealed that there was a significant difference in the report of incivility among private and public employees. Employees from public organisations reported significantly higher workplace incivility. However, the result indicated that age and gender had no significant influence on workplace incivility. Based on these findings, management should put measures in place to minimize perceived organisational politics in order to reduce uncivil behaviour in workplace.

De Clercq, Haq, Azeem and Ahmad (2019) investigated the moderating role of employee resilience in the relationship between employees' perceptions of workplace incivility and their helping behaviour, as well as the buffering role of political skill in this process. Three-wave, time-lagged data collected from employees and their supervisors revealed that employees' exposure to workplace incivility diminished their helping behaviour through their sense of job dissatisfaction. This moderating role of employee resilience was less salient, however, to the extent that employees were equipped with political skill. Their research accordingly pinpoints a key mechanism—namely, unhappiness about their job situation—through which rude coworker treatment links to lower voluntary workplace behaviours among employees, and it reveals how this mechanism can be better contained in the presence of political skill.

He, Costa, Walker, Miner and Wooderson (2019) examined how coworkers' (dis)similarity in political identity is related to the quality of their interpersonal interactions and subsequent well-being. Their study predicted that political identity

dissimilarity is associated with experiences of workplace incivility and, in turn, declines in psychological and occupational well-being. Their study also tested the hypotheses in a four-wave survey study conducted during the 2012 U.S. presidential election using structural equation modeling. Their results indicated that political identity dissimilarity was associated with increased reports of incivility experiences instigated by coworkers, which, in turn, was associated with increased burnout and turnover intentions and diminished job satisfaction. The relationship between incivility and well-being was mediated by psychological distress. Overall, the findings demonstrate that political identity dissimilarity is detrimentally related to job attitudes and well-being via triggering workplace incivility, which provides meaningful implications for organisations on how to mitigate the negative influences of identity dissimilarity.

Chahar and Hatwal (2021) sought to analyze the impact of organisational politics on employee resilience and work place incivility in IT and ITes organisation in Indian Context. In addition, explore whether employee resilience mediates the relationship between organisation politics and incivility at the work place. The study adopted a descriptive research design using a cross-sectional data approach was selected for this study. Univariate and bi- variate data analysis techniques were used to analyze the data for drawing inference. The finding confirms the significant effect of organisation politics on workplace incivility. Employees who perceived organisational politics also tended to engage in workplace incivility Test statistics confirms the moderating role of employee resilience in the relationship between Organisational politics and employee work

place incivility. Their study recommended that the actions taken by management like building trust and ability among employee to meet the challenges, promoting employee to give solution to the problem, giving more opportunity for learning and growth, promoting meditation and yoga to keep emotion calm and in control etc.

Hence, the study hypothesized that;

H1: Organisational politics has a significant effect on workplace incivility

H2: Employee resilience has a significant influence on workplace incivility

H3: Employee resilience does mediate the relationship between organisational politics and workplace incivility

Conceptual Framework

A conceptual framework is a theoretical structure of assumptions, principles, and rules that holds together the ideas comprising a broad concept (Zikmund, 2003). The study examines how employee resilience, mediates the relationship between organisational politics and workplace incivility in the higher educational institution. The framework is shown in figure 1.

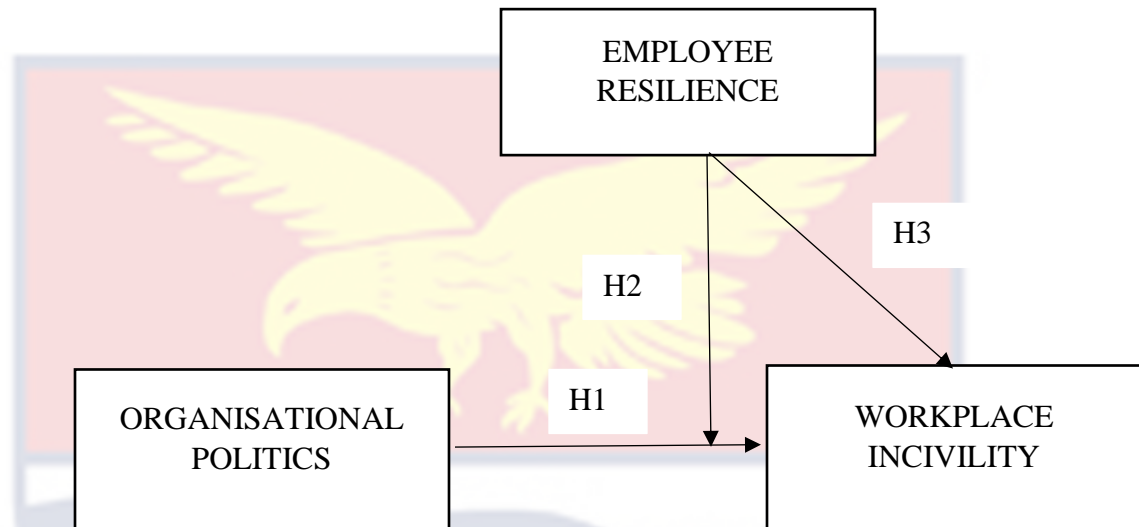

Figure 1: Conceptual framework

Source: Researcher's construct (2022)

The study proposes that organisational politics has both a direct and indirect positive influence on workplace incivility and a direct positive influence on employee resilience. The study also proposes that the employee resilience has a positive/negative influence on workplace incivility based on the assertion of prior scholars.

Chapter Summary

The chapter addressed the literature on theoretical, conceptual and empirical concerns linked to organisational politics, workplace incivility and employee resilience as documented in past research. Important concerns and insights from the review informed the conceptual framework of the study. The review will further prove valuable in the methodology, analyses, presentation of findings, debates,

conclusions and suggestions. The next chapter provides the technique utilized to carry out this investigation.



CHAPTER THREE

RESEARCH METHODS

Introduction

This chapter describes the methods and procedures used in conducting the research. Research methodology represents the systemic investigation aimed at solving research problems (Maxwell, 2012; Kothari, 2004). According to Mishra and Alok (2011), research methodology is the science behind how a particular research activity is carried out. It spells out the systematic steps taken in studying a particular research problem. This section presents a description of the research approach and research design, the study area, the population, and the sample size and sampling technique which are used for the research. It also provides a vivid description of data sources, data collection instrument, data collection procedure, as well as procedures for data processing and analysis.

Research Design

It was prudent to select the appropriate research design that would enable the researcher to answer the research questions and put up useful and perfect assumptions with less difficulty. A research design is a detailed strategy which the researcher followed while gathering the study data and conducting the research analysis (Turner, 2014). According to Potwarka, Snelgrove, Drewery, Bakhsh and wood (2019), a research design is considered as a set of arrangements made to collect and analyze data in a way that seeks to integrate compliance with the purpose of the research process and economics. According to Young and Javalgi

(2007) a master plan that describes the process and methods for obtaining and analyzing the required information is considered a research design.

The three main research designs that have usually characterized social science research are descriptive, explanatory and exploratory (Creswell & Clarke, 2017; Rovail et al., 2013). The exploratory research is conducted to have a better understanding of a prevailing problem and generally does not lead to a definite outcome. It is flexible and provides the basis for future study. According to Creswell and Clarke (2017), the exploratory design focuses on obtaining facts and understanding social reality. Thus, the objective of the exploratory design is to detect significant challenges and variables in a real-world situation.

The explanatory research is undertaken to give details as to why a phenomenon happened and to predict future events. It generally concentrates on “why questions” in a bid to appreciate the relationships that exist between variables (Babbie, 2010). Though the explanatory research does not offer conclusive results due to lack of statistical strength, it enables the researcher to decide on how and why things occurred.

The descriptive design offers descriptions of observations about a particular phenomenon (Creswell & Clarke, 2017). It concentrates on answering the how, what and where questions rather than why questions. A distinctive characteristic of the descriptive design is that it often assists a researcher to present comparisons, similarities, and contrast between phenomena, and in so doing, enhances the understanding of social reality (Babbie, 2010).

The current study adopted the explanatory research design. Thus, driven by the concept of causal relationships between constructs –organisational politics and employee resilience (Independent variable) and workplace incivility (variable dependency). Explanatory studies are presented by research ideas that describe the nature and direction of the relationship between study variables. In line with Zikmund Carr, Babin, and Griffin (2013) explanatory research design is performed for you to discover the volume and nature of cause-and-impact relationships. Potwarka, Snelgrove, Drewery, Bakhsh and wood (2019) further restated that the premises of positivism research paradigm are to institute cause-impact relationships. Positivists pursue for consistencies to make predictions and installed scientific rules.

Research Approach

According to Creswell and Creswell (2016), there are three approaches to research; (a) qualitative, (b) quantitative, and (c) mixed methods. Quantitative research approach deals with explaining phenomena by collecting numerical data that are analysed using mathematically based methods (in particular statistics) (Creswell, 2014). Quantitative research approach is a research strategy that adopts quantification in the collection and analysis of data (Bryman, 2012; Lincoln & Guba, 1985). Quantitative research approach (normally using deductive logic) seeks regularities in human lives, by separating the social world into empirical components called variables which can be represented numerically as frequencies or rate, whose associations with each other can be explored by statistical

techniques, and accessed through researcher-introduced stimuli and systematic measurement (Rahman, 2017).

Qualitative research approach involves collecting and analysing non-numerical data (e.g., text, video, or audio) to understand concepts, opinions or experiences (Creswell, 2014). It can be used to gather in-depth insights into a problem or generate new ideas for research. Also, in qualitative research approach, subjectivity is often introduced during data collection procedures and analysis. Qualitative research approach is used to understand how people experience the world. While there are many approaches to qualitative research, they tend to be flexible and focus on retaining rich meaning when interpreting data.

Mixed research approach requires a purposeful mixing of methods in data collection, data analysis and interpretation of the evidence (Creswell, 2014). Mixed research approach is a research approach whereby the researcher collects and analyse both quantitative and qualitative data within the same study. Mixed research approach draws on potential strengths of both qualitative and quantitative methods, allowing researchers to explore diverse perspectives and uncover relationships that exists between the intricate layers of our multifaceted research questions.

This current study adopted the quantitative research approach. This is because the measurements of the items in the scale were numerically rated by the respondents based on predetermined rating scales (7-point Likert scale). Besides, per the nature of the primary data required, design of the data collection instrument, research objectives, statistically application for data processing, statistical tools for

data analysis as well as the theoretical foundation of the study, the adoption of quantitative research design becomes most preferred an obvious option in the face of both qualitative and mixed research approaches.

Study Area

The University of Cape Coast was established in 1962 out of a dire need for highly qualified and skilled manpower in education and was affiliated to the University of Ghana. It was established to train graduate teachers for second cycle institutions such as teacher training colleges and technical institutions, a mission that the two existing universities were unequipped to fulfil. On October 1, 1971, the College attained the status of a full and independent University, with the authority to confer its own degrees, diplomas and certificates by an Act of Parliament - The University of Cape Coast Act, 1971 [Act 390] and subsequently the University of Cape Coast Law, 1992 [PNDC Law 278]. Since its establishment, the university has added to its functions the training of education planners, administrators, agriculturalists, and health care professionals.

The University of Cape Coast as of September 2021 has a total student population of 74,720 (www.ucc.edu.gh). The University of Cape Coast is organized into six colleges, namely Agriculture and Natural Sciences, Distance Education, Education Studies, Humanities, and Legal Studies, Health and Allied Sciences, and School of Graduate Studies and Research. Each college has different schools and departments under them. The University Council is the executive body of the university's governance system. It has overall responsibility for the administration of the University and the management of its resources. The Council superintends

relations between the University and outside bodies on matters. The Council in carrying out its duties is responsible for the appointment or nomination of certain members of various committees.

University of Cape Coast has 12 directorates that perform functions to support the university. The administrative and support functions of the University are grouped into the following Directorates; Academic Planning and Quality Assurance, Finance, Information and Communication Technology Services, Internal Audit, Procurement, Physical Development and Estate Management, Research, Innovation and Consultancy, and University Health Services. All these directorates are managed by administrators. The vision of the University is to have a university that is strongly positioned, with worldwide acclaim. Its mission is to provide a quality education through the provision of comprehensive, liberal and professional programmes that challenge learners to be creative, innovative and morally responsible citizens.

Population

Population according to Amrhein, Trafimow and Greenland (2019) consists of the entire group of persons who are of interest to a researcher and who meet the criteria that the researcher is interested in studying, or a set of individuals having some common characteristics. According to Saunders, Thornhill and Lewis (2007) population is the full set of cases from which a sample is drawn. Population can be seen as the target group about which the researcher is interested in gaining information and drawing conclusion (Leedy & Ormrod, 2010; Robson, 2002). According to the Directorate of Human Resource of the University of Cape Coast,

the staff constitutes Senior staff, Senior members and the Junior staff, out of which one thousand, five hundred and seventy (1570) are senior staff.

Senior staff were chosen for this study because the actual purpose of the University of Cape Coast is centered on lecturing and learning, as such, much focus of engagement, welfare and reward package's purpose of management is mainly on senior members which often results in little on other employees within the institution. As a result, this creates the segregation among other staff of the institution, where attention may be given to the affiliations to certain groups who may tend to have resulting in incivility among workers. Hence, senior staff of the University of Cape Coast possess the needed characteristics needed for this kind of study, considering employee resilience, organisational politics and workplace incivility.

Sampling Procedure

Sampling is a statistical approach of acquiring a representative population to take information or data concerning a whole population by analyzing only a portion of it (Babbie, 2007). Sampling is a process used in statistical analysis in which a predetermined number of observations are taken from a larger population. Sampling has also been referred to the act, process, or technique of selecting a suitable sample, or a representative part of a population for the purpose of determining parameters or characteristics of the whole population (Strouse, Donovan & Fatima, 2019; Malhotra & Birks, 2007; Bassey, 1995). According to Bryman (2009) sampling is very essential because, in almost all cases, it is not possible to study all the members of a population.

Three basic types of sampling techniques exist. These are non-probability sampling, probability sampling and mixed approach sampling techniques. According to Buchanan and Bryman (2009) in non-probability sampling, not all the members of the population have the opportunity to be selected for the sample. The definition of a non-probability sampling technique defines the population that will give a reliable inference about a population. Non-probability sampling techniques include convenience sampling, quota sampling, network sampling and purposive sampling.

Probability sampling on the other hand, has its elements having equal chance or opportunity of being selected for the sample. This sampling technique tends to increase the likelihood of achieving the aim of choosing members that precisely represent the entire population from which the members were chosen. Probability sampling technique includes simple random, stratified, cluster or multi stage sampling (Cavana, Delahaye, & Sekaran, 2001). Estimating the extent of probable success is the main aim of the probability sampling technique (Malhotra & Birks, 2007). As a result, probability theory serves as the basis for a member of a population to be included in a sample. Mixed sampling technique, according to Wurtz (2015) is a sampling strategy whereby the combination of non-probability and probability sampling techniques are employed at different stages in research.

In this current study, the researcher adopted the simple random sampling technique for the selection of the respondents from the sampling frame. As such, the Krejcie and Morgan (1970) sample determination table was adopted to provide the sample size from the total population within the institution. As such, 310 senior

staff was selected as the sample size. Unique identification numbers were generated for all the elements in the sampling frame and through the lottery method, the qualified respondents were randomly selected through hand-picking method (Lohr, 2019; Mohammed, Ibrahim, Siri & Noor, 2019; Sharma, Hickman & Nassir, 2019). This gave each respondent equal chance of selection (Kim & Wang, 2019; Kadilar & Cingi, 2006; Vijayalakshmi & Sivapragasam, 2019) and also supported the parametric approach to analyzing the primary data (Choromanski, Pacchiano, Parker-Holder, Hsu, Iscen, Jain & Sindhvani, 2019).

Data Collection Instrument

The main instrument used in the data collection process was the survey questionnaire. A survey questionnaire is a formalized set of questions for obtaining information from respondents (Singer & Couper & Peterson, 2017; Malhotra & Birks, 2007). Young and Javalgi, (2007) provided that surveys using questionnaires are the most widely-used data-gathering technique in research and can be used to measure issues that are crucial to the management and development of businesses (Malhotra & Birks, 2007). In this study, the closed ended questions were used. The closed ended questions require respondents to choose from among a given set of responses and require the respondents to examine each possible response independent of the other.

The close-ended items employed comprised a section for the characteristics of the respondents that the researcher is investigating, and as well as the Likert scale, which indicates the level of agreement to research questions and multiple-choice questions (Leedy & Ormrod, 2010). McColl (2005) posits that there are

distinct advantages in using questionnaires rather than interview. According to him, data analysis is made easier and straight forward when structured questions are used for primary data gathering. The researcher's decision to use questionnaire stemmed from the fact that it is the best method by which reliable information can be obtained from a large population. This is supported by Taylor, Sinha and Ghoshal (2011) who asserted that the use of questionnaire is a sensible way for data collection if factual information is needed from a substantial number of people.

A 7-point Likert scale was used. A Likert scale is an ordered scale from which respondents choose one option that best aligns with their view (Leedy & Ormrod, 2010). The 7-point likert scale was used because it measures respondents' concern by indicating the extent of their levels of agreement to particular questions or statements. The scale in which responders specify their level of agreement to a statement was typically in seven points: (1) Least level of Agreement; through to; (7) Highest level of Agreement.

The questionnaire was made up of four subdivisions. These subdivisions were in line with the specific objectives of this study. Section A of the questionnaire measured the Demographic data of the respondents and had five variables in all. Section B measured organisational politics at the University of Cape Coast. In a similar fashion, section C measured the workplace incivility which comprised of 10 indicators/items. Finally, the section D contained items required to measure employee resilience of the employees.

Pre-test

To ensure the validity of the constructs, extant empirical review was carried out and this informed the choice of the items that were included in the scale. Again, initial scale that was developed was administered to 5% of similar sample size from the University of Cape Coast, Cape Coast. Detailed discussion was done with these respondents which then informed the alteration of the scale. This procedure was based on the recommendation presented by Keesler and Fukui, (2020). After this, the questionnaire was submitted to the supervisor for more clearing up and authorization. Again, to ensure the reliability of the scale, Principal Component Factor Analysis was piloted where the results of Kaiser-Meyer-Olkin [KOM] measure of sample adequacy and Barlett's Test of sphericity proved helpful. The factors created were then evaluated in terms of their reliability through the internal consistency approach as measured by the Cronbach's Alpha.

Validity and Reliability

In order to ensure content validity of the instrument, the study ensured proper definition measuring items, scale scrutiny by experts and scale pre-testing. These were in line with the principles of McDaniel and Gates (1996). Reliability and validity are two key components to be considered when evaluating a particular instrument. The level of the reliability of an instrument is measured by Cronbach's Alpha value (Saunders & Lewis, 2012). As posited by Pallant (2016), Cronbach's alpha coefficient for variables is generated to validate the reliability of the instrument. Pallant (ibid) also indicates that scales with a Cronbach's alpha coefficient of 0.70 and above are considered reliable. However, studies such as

Boohene, Agyapong and Asomaning (2012) support coefficient of 0.5. The results of the pre-test were used to assess the reliability of the instrument. The result is presented in Table 1.

Table 1: Questionnaire Items and Their Reliability Coefficients

Variable	Questionnaire Items	Cronbach's Alpha
Organisational Politics	10	0.803
Workplace Incivility	10	0.807
Employee Resilience	10	0.801

Source: Field survey (2022)

Table 1 provided the values of Cronbach's alpha for all the variables. It appears from the table that the values of Cronbach's alpha ranged between 0.801 and 0.807. These values are all well above the minimum value of 0.50. In this case, based on the criteria of Boohene, Agyapong and Asomaning (2012), it can be concluded that all the items of measurement showed a high level of reliability and have an acceptable level of reliability.

Data Collection Procedure

Permission for the data collection exercise at the University of Cape Coast was sought from the authority of the university when a letter was issued by the Graduate School of School of Business in University of Cape Coast was sent to the university's authority. Permission for the primary data collection was then granted. The sampling frame was then made available to the researcher. The purpose of the study was explained to all participants. Consent of the respondents was sought. Date for questionnaire distribution to the participants were set on some agreed

terms. The terms were that respondents will answer the questionnaire during their break time and they will not be forced to answer any question don't understand or agree to.

The drop-and-pick survey approach was adopted. The questionnaire was self-administered to the respondents. Trained research assistants also supported the primary data collection exercise. The above procedures helped the researcher to collect the required data needed for the analysis of the research objectives. The survey was administered from 20th June, 2022 and collected on 20th July, 2022.

Response Rate

In this study, the sample size was two hundred and sixty-nine (269) senior administrators. This means that a total of 310 questionnaires were issued from which 293 were filled and returned which represents a response rate of 88.5%. This means 17 (approximately 5.5%) was not returned as it can be seen in Table 2.

Table 2: Response Rate

Questionnaire	Count	Percentage (%)
Returned	293	94.5
Non-Returned	17	5.5
Total	310	100

Source: Field survey (2022)

The 94.5% return rate was considered to be satisfactory based on Mugenda and Mugenda (2008) who opined that a response rate of 50% is enough for analysis and reporting; a rate of (60%) is good and a response rate of (70%) and over is excellent. The high response rate was accredited to the fact that the candidate had contacts in the study area and that facilitated the data collection process. Besides,

the candidate personally administered the questionnaires and made a lot of efforts to make many follow-ups between research assistants and the respondents calls to clarify queries with the intention to improve the high response rate.

Data Processing and Analysis

According to Vonrhein et al. (2011) data analysis entails simplifying data and explaining it in a manner that seeks to answer the research questions posed. Data analysis was also defined by Yan, Wang, Zuo and Zang, (2016) as the process of bringing order, structure and meaning to the mass of information collected as stated in Mertens (2005). Analysis of data is a process of editing, cleaning, transforming, and modelling data with the goal of highlighting useful information, suggestion, conclusions, and supporting decision making (Lyashenko, Deineko, Zeleniy, & Tabakova, 2021). The use of analytics requires reducing complex data into meaningful and actionable information (Imanbayev, Sinchev, Sibabayeva, Mukhanova, Nurgulzhanova, Zaurbekov, & Baibolova, 2021). Brink, Van der Walt and Rensburg (2012) indicated that the main aim of data analysis is to organize, give structure to and derive meaning from data.

In terms of quantitative research, deciding on how to analyze the data collected for the purpose of providing answers to the research questions posed is the main emphasis of data analysis (Kumar, 2011). The statistical tools employed for this study were Statistical Package for Services Solution (SPSS) version 26 and SmartPLS version 3. The SPSS was employed for descriptive analysis and the Smart PLS was employed for structural equation modelling based on the questions

of this study. The descriptive statistics (frequencies and percentages) were employed to determine the characteristics of the respondents.

Structural Equation Modelling

Structural equation modelling (SEM) is a second-generation statistical technique that “enables researchers to incorporate unobservable variables measured indirectly by indicator variables. They also facilitate accounting for measurement error in observed variables” (Chin, 1998 as cited in Hair, Jr., Hult, Ringle & Sarstedt, 2016:3). Partial Least Squares-Structural Equation Modelling (PLS-SEM) uses available data to estimate the nexuses of the path in the model to minimise the residual variance of the endogenous constructs. SEM is made up of two key elements; measurement equations (by confirmatory factor analysis) and structural equations (by path analysis). Whereas confirmatory factor analysis models (CFA) are used for construct validation and scale refinement, path analysis is used to display the relationships that exist among study constructs.

PLS-SEM estimates path model nexuses that maximize the R^2 values of the endogenous constructs (Hair et al., 2014). It is also useful when dealing with complex models and small sample sizes (Hair et al., 2014; Rezaei & Ghodsi, 2014; Rezaei, 2015; Shahijan, Rezaei, Preece & Ismail, 2014). PLS-SEM is also more appropriate where theory is less developed (Ravand & Baghaei, 2016; Rönkkö & Evermann, 2013). According to Hair et al. (2014), there are two forms of measurement scale in structural equation modelling: Formative or Reflective. Whereas in formative measurement scale it is the indicators that cause the constructs of the study, in a reflective measurement scale it is the constructs that

cause indicators of the study. The current study employed reflective measurement scale because all the indicators were caused by the constructs.

Furthermore, Jeon (2015) has itemised a number of benefits SEM has over other models such as regression. These benefits are: Firstly, SEM uses “latent variables” which allows multiple indicators to capture constructs validly and reliably. Secondly, SEM makes the causal equation model between latent variables clearer as compared to regression. Thirdly, SEM allows one or more independent variables to be regressed on one or more dependent variable. Fourthly, In SEM, a researcher can show the direct effect, indirect effect, and total effect because several exogenous variables and endogenous variables can be estimated simultaneously. PLS is quite robust with regard to inadequacies like skewness, multicollinearity of indicators and misspecification of the structural model (Cassel et al, 1999). In SEM, confirmatory factor analysis, correlation analysis, and regression analysis can be conducted at one time in a model. In line with the benefits above associated with SEM, this study relied on PLS-SEM to test the various hypotheses.

Moderation Procedure in SEM

Hair, Hult, Ringle and Sarstedt (2017) explain moderating effect as when a third variable interferes between two other related constructs “Moderator variables fascinate part of the relationship between the construct in Partial least squares path model that is an exogenous and an endogenous construct. Thus, moderators tell the "true" relationship between an exogenous and an endogenous construct. In this study, the moderating role of employee resilience is tested on the relationship between organisational politics (exogenous) and workplace incivility

(endogenous). Hair et al. (2017) laid down a systematic moderator analysis process in PLS-SEM, to solve the misemployment of Baron and Kenny's procedure in the PLS-SEM field (Nitzl, Roldan & Cepeda, 2016; Carrión, Nitzl & Roldán, 2017).

Hair et al. (2014) argue that in a structural equation when both direct and indirect effect is significant, then, there is mediation.

Validity and Reliability of the Model

There are several criteria for assessing model structures. In general, a systematic application of the different criteria is carried out in a two-step process, (1) the assessment of the measurement model and (2) the assessment of the structural model.

1) Assessment of Measurement Models

Assessment of reflective measurement models includes composite reliability to evaluate internal consistency, individual indicator reliability, and average variance extracted (AVE) to evaluate convergent validity. In addition, the Fornell-Larcker criterion and cross loadings are used to assess discriminant validity (Hair et al, 2013).

Internal Consistency Reliability

It is a form of reliability used to judge the consistency of results across items on the same test. It determines whether the items measuring a construct are similar in their scores (i.e., if the correlations between the items are large) (Drolet & Morrison, 2001). The composite reliability is a more appropriate measure of internal consistency than the Cronbach's alpha (Rossiter, 2002). The composite reliability varies between 0 and 1, with higher values indicating higher levels of

reliability. It is generally interpreted in the same way as Cronbach's alpha. Specifically, composite reliability values of 0.60 to 0.70 are acceptable in exploratory research, while in more advanced stages of research, values between 0.70 and 0.90 can be regarded as satisfactory (Nunally & Bernstein, 1994).

Convergent Validity

Convergent validity is the extent to which multiple items to measure the same concept agree (MacKinnon, 2008). Anderson and Gerbing (1988) stated that convergent validity is established if all factor loadings for the items measuring the same construct are statistically significant. According to Hair et al. (2019) convergent validity could be accessed through factor loadings and the average variance extracted (AVE). Hair, Ringle, and Sarstedt, (2019) point out that to establish convergent validity, factor loadings must be 0.60 and above. An AVE value of 0.50 or higher indicates that, on average, the construct explains more than half of the variance of its indicators. Conversely, an AVE of less than 0.50 indicates that, on average, more error remains in the items than the variance explained by the construct.

Discriminant Validity

Discriminant validity is the extent to which a construct is truly distinct from other constructs by empirical standards. Thus, establishing discriminant validity implies that a construct is unique and captures phenomena not represented by other constructs in the model (MacKinnon, 2008). The Heterotrait - Monotrait Ratio (HTMT) is a means of determining the discriminant validity of a PLS-SEM model. According to Henseler, Ringle & Sarstedt (2015), a latent construct has

discriminant validity when its HTMT ratio is below 0.850. The Fornell-Larcker criterion is also an approach to assessing discriminant validity. It compares the square root of the AVE values with the latent variable correlations (Fornell and Larcker, 1981). Specifically, the square root of each construct's AVE should be greater than its highest correlation with any other construct. (Hair et al. 2013).

2) Assessment of the structural model

The first essential criterion for the assessment of the PLS-SEM is the coefficient of determinations (R^2) for each endogenous construct. R-square (R^2) measures the explained variance of a latent variable relative to its total variance. Hair et al. (2014) advanced that a coefficient of determination (R^2) of 0.25, 0.5 and 0.75 are considered as weak, moderate and substantial respectively for structural models. The next step to assess the structural model comprises the evaluation of the regression coefficients between the validated latent variables. A regression coefficient magnitude indicates the strength of the relationship between two latent variables. Furthermore, regression coefficients should be significant at the 0.05 level, in order to determine the significance (Bradley & Tibshirani, 1993).

Finally, another assessment of the structural model involves the model's capability to predict. The predictive relevance of the structural model is assessed by the Stone-Geisser's Q^2 statistic (Stone, 1974). In the structural model, Q^2 values larger than zero for a certain reflective endogenous latent variable indicate the path model's predictive relevance for this particular construct. As a relative measure of predictive relevance, values of 0.02, 0.15, and 0.35 indicate that an exogenous construct has a small, medium, or large predictive relevance for a certain

endogenous construct. (Hair et al, 2016). It is also imperative to measure the impact of individual endogenous variables on the exogenous variable. This is achieved by assessing the effect size (f^2). As posited by Cohen (1988), f^2 values of 0.02, 0.15, and 0.35, respectively, represent small, medium, and large effects of the exogenous latent variable.

Specifying the Structural and Measurement Model

The section specifies the structure of the model of this study. It indicates the exogenous and the endogenous variables with the various indicators. The structural model is specified in figure 2. There is one exogenous variables, one moderating variable and one endogenous variable in this study. The exogenous variable was; Organisational Politics (OP). The moderating variable was Employee Resilience (ER). The endogenous variable was Workplace Incivility (WI). The latent variable; Organisational Politics was measured by ten indicators (*OP1, OP2, OP3, OP4, OP5, OP6, OP7, OP8, OP9 and OP10*).

Employee Resilience was measured by ten indicators (*ER1, ER2, ER3, ER4, ER5, ER6, ER7, ER8, ER9, and ER10*). Workplace Incivility had the ten indicators (*WI1, WI2, WI3, WI4, WI5, WI6, WI7, WI8, WI9, and WI10*). There are three (3) paths hypotheses in the model (figure 2).

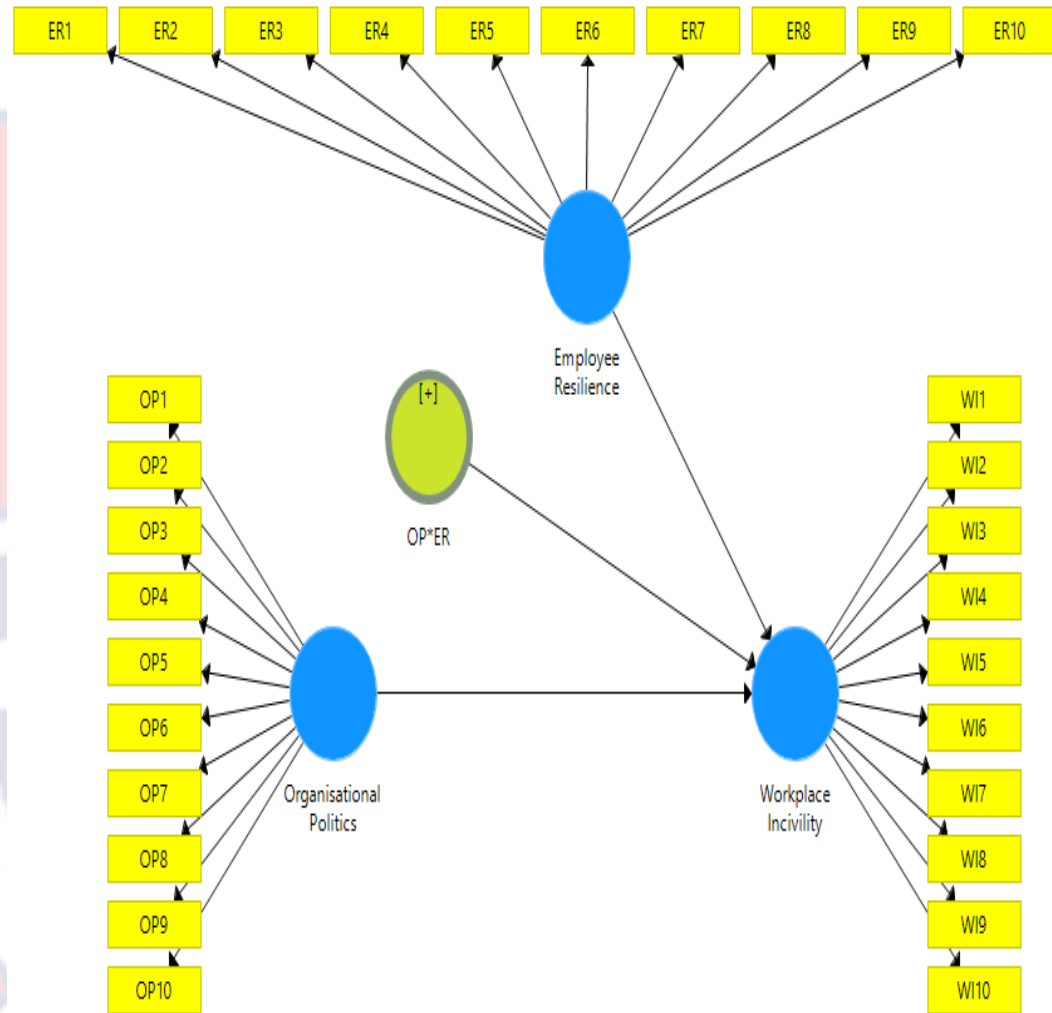

Figure 2: Structural Model

Source: Smart PLS (2022)

Common Method Bias

Common method bias can occur due to self-report measures (Podsakoff, MacKenzie, Lee, & Podsakoff, 2003). Common method bias is a biasing of results that are caused by a common method, such as a single survey (Favero & Bullock, 2015). Another possible cause of common method bias is the implicit social desirability associated with answering questions in a questionnaire in a particular

way, again causing the indicators to share a certain amount of common variation (Kock & Lynn, 2012). To deal with common method bias, only previously tested scales were used (Alfes, Shantz, Truss, & Soane, 2013).

Common method bias (CMB) can also be tested using Harman's single factor test (Podsakoff & Organ, 1986) and VIF scores (Kock & Lynn, 2012). Podsakoff and Organ (1986) suggested that a single factor would emerge from a factor analysis or one general factor would account for most of the covariance in the independent and criterion variables if CMB was a serious problem.

Ethical Consideration

As indicated by Saunders, Lewis and Thornhill (2007), any social researcher should seek permission from the respondents stating clearly their intentions and being guided by research ethics. The respondents were therefore informed of anonymity and confidentiality. The researcher assured the respondents that their names would not be disclosed. As such, all information received from them (respondents) would be treated with the highest degree of confidentiality. In addition to this, the researcher also informed the respondents that they were free to cease to give any response if they so wish. Finally, the researcher did not withhold any information about the study's possible risks, discomfort or benefits or deliberately deceive study subjects on these matters.

Chapter Summary

This chapter explained in details the methodology followed in carrying out the research. The theoretical foundation of the study, research approach, research design, sampling technique, procedures for data collection, data collection

instrument and data analysis were thoroughly discussed. The positivism research paradigm was used as the theoretical foundation of the study. The quantitative research approach was employed for the study because the data collected using questionnaire was quantitatively analyzed by using both descriptive and inferential statistics. Descriptive research design was adopted to ensure objectivity in the research process. Simple random sampling technique was used to select samples for the study. The data collection instrument used was a 7-Likert scale questionnaire. The Statistical Package for Social Sciences (SPSS) version 26 and the SMART PLS 3 were the software used to analyze the data.

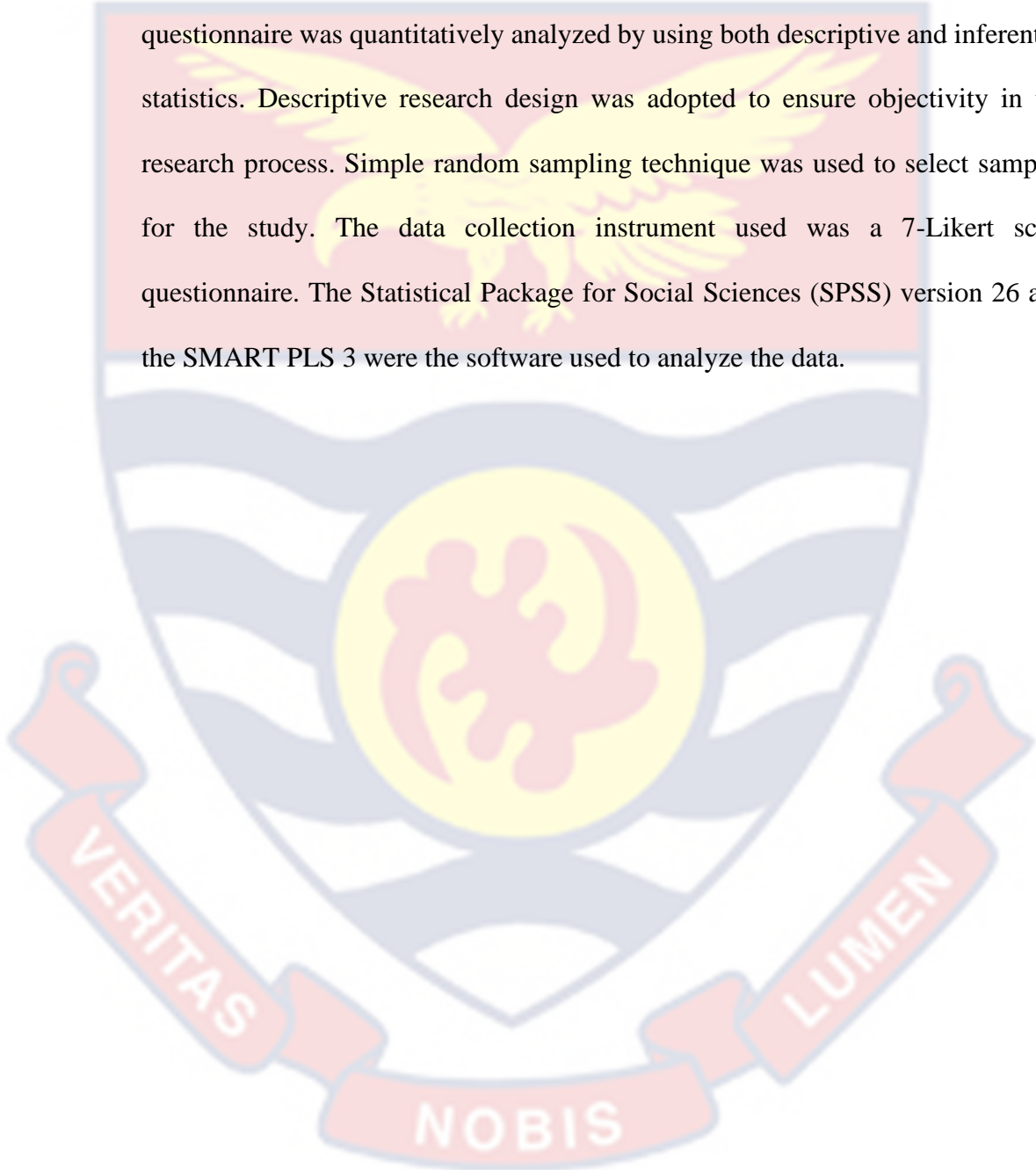

CHAPTER FOUR

RESULTS AND DISCUSSION

Introduction

This study aimed to examine the influence of organisational politics on workplace incivility: the moderating role of employee resilience. This chapter presents an analysis of the data collected from respondents. The main instrument used for this study is a structured questionnaire. The statistical tools employed were; frequencies, percentages and structural equation modelling. This chapter reflects on the core research objectives as outlined in chapter One in line with the main research goal. The first section discusses the response rate and personal data of respondents; however, the second section discusses the study's research objectives.

The next part of the section discusses the interrelationships between the variables include; organisational politics (OP), workplace incivility (WI) and employee resilience (ER). The technique of PLS is based on an iterative combination of analysis and regression of main components. Its benefit is that, in the sense of a given model, it simultaneously estimates all path coefficients and individual item loadings.

Descriptive Results for Socio-Demographic Characteristics

This section provides results on the nature of the respondents for this study. The demographic variables of interest were descriptively measured (frequency and percentage) and presented in Tables for easy understanding.

Table 3: Demographic Characteristics for Respondents

Background characteristics	Frequency	Percentage
Sex		
Male	177	60.40
Female	116	39.60
Total	293	100
Age		
21-30 years	103	35.20
31-40	141	48.10
41-50	38	13.97
51-60	10	3.40
Above 60	1	0.30
Total	293	100
Marital status		
Single	148	50.50
Married	145	49.49
Total	293	100
Academic qualification		
Postgraduate	41	13.99
First degree	160	54.61
SHS/HND	92	31.40
Professoral	0	0.00
Total	293	100

Work Experience

1-5 years	145	49.49
6-10 years	91	31.06
11-15 years	41	13.99
16 and above	16	5.46
Total	293	100

Source: Field survey (2022)

Table 3 clearly illustrates that there were more male participants than their female counterparts in this survey. More than half of the respondents (60.40%) were males while the remaining respondents, (that is 39.60%) were females. This implies that a lot of males appeared to have been employed as senior staff at the University of Cape Coast, Ghana. However, with respect to gender inequality in terms of employment in the country, it is surprising. For example, from the Annual Report of Ghana Statistical Service (2020), it is generally known that labour force participation rate of females remains lower than that of males. In Ghana, the labour force participation rate of females has often trended below that of men even though females constitute over half of the entire population. In addition, the unemployment rate is estimated to be higher among women than men, whilst at the same time, the share of females in wage employment is also lower than that of males.

On the age distribution of the respondents, it was found out that most of the respondents are between the ages of 31 and 40 representing 48.10%. This higher percentage of staff gives the impression that there are more youthful staff within the various departments as senior staff at the University of Cape Coast, Ghana.

Again, the result showed that respondents representing (35.20%) were below 30 years which implies that in the service, most of the respondents are in their prime age and that the organisation can be considered to have had a lot of potentials in terms of development in the future. In addition, 13.97% of the respondents were between the ages of 41 and 50 years. The least age group was those above 60 years representing (0.30%) in the institution. The overall implication is that relatively a small percentage number of employees are very young and is deemed to have more potential to influence future performance through their various capacities. It can also be seen from the table that majority of respondents, that is, 148 representing (50.50%) of the sampled population were single, whilst 145 respondents representing (49.50%) of the population were married.

From the Table 3, with the educational levels of the staff, it was also realized that 160 respondents representing (54.61%) had had their first-degree education. Also, with regards to SHS/HND, 92 of them representing (31.40%) were found to be in this category representing a high proportion of senior staff in the University of Cape Coast, Ghana. More so, a substantial percentage number of the staff had their postgraduate education. With this category of staff, a total of 41 representing 13.99% were the postgraduates. Finally, no senior staff (0.0%) had professoral education. From the table it is realized that most workers in the University of Cape Coast, Ghana, consider education as important to the growth of the country. The study results from the table highlight the significance that the organisation attaches to education as most senior staff in the institution are qualitatively gifted with

educational prowess and this could also be attributed to the nature of care giving rendered.

In terms of how long each employee has worked in the University of Cape Coast, Ghana, it was found that most of them fell within 1 and 5 years of experience in working as senior staff at the University of Cape Coast, Ghana. Within these years, 145 (49.49%) had worked within them, while 91(31.06%) had worked in the University of Cape Coast, Ghana, as senior staff between 6 and 10years. This is followed by those who had worked between 11 and 15 years with a total number of 41 (13.99%) while those who have worked for more than 16 years make up 16 (5.46%).

Findings of the Research Objectives

It is established that, the study sought to examine the influence of organisational politics on workplace incivility: the moderating role of employee resilience. This section presents results and analysis based on the three key questions of this study. Both descriptive and inferential statistics are used in analysing the data. As it has been indicated in the methods, the design of this research is descriptive and adopts a quantitative method. The results and analysis are presented chronologically based on the stated questions of this study.

Research Objective One: Influence of Organisational Politics on Workplace Incivility

This section sought to examine the first objective of the study, thus, the influence of organizational politics on workplace incivility. The analysis of the objective was contingent upon the acceptable criteria in the measurement and

structural models. As captured in the ensuing figure and tables, the measurement model (indicator loadings, IL; internal consistency, convergent validity, CV; and discriminant validity, DV) was first evaluated followed by the structural model (coefficient of determination, R^2 ; significance, p ; predictive relevance, Q^2 ; effect size, f^2).

Measurement Model

The measurement model comprising indicator loadings (IL), internal consistency, convergent validity (CV), and discriminant validity (DV) was first evaluated.

Indicator Loadings

Commencing with the indicator acceptability on the Constructs, the results on Figure 2 revealed that loadings were well within the recommended criteria of 0.60 and above.

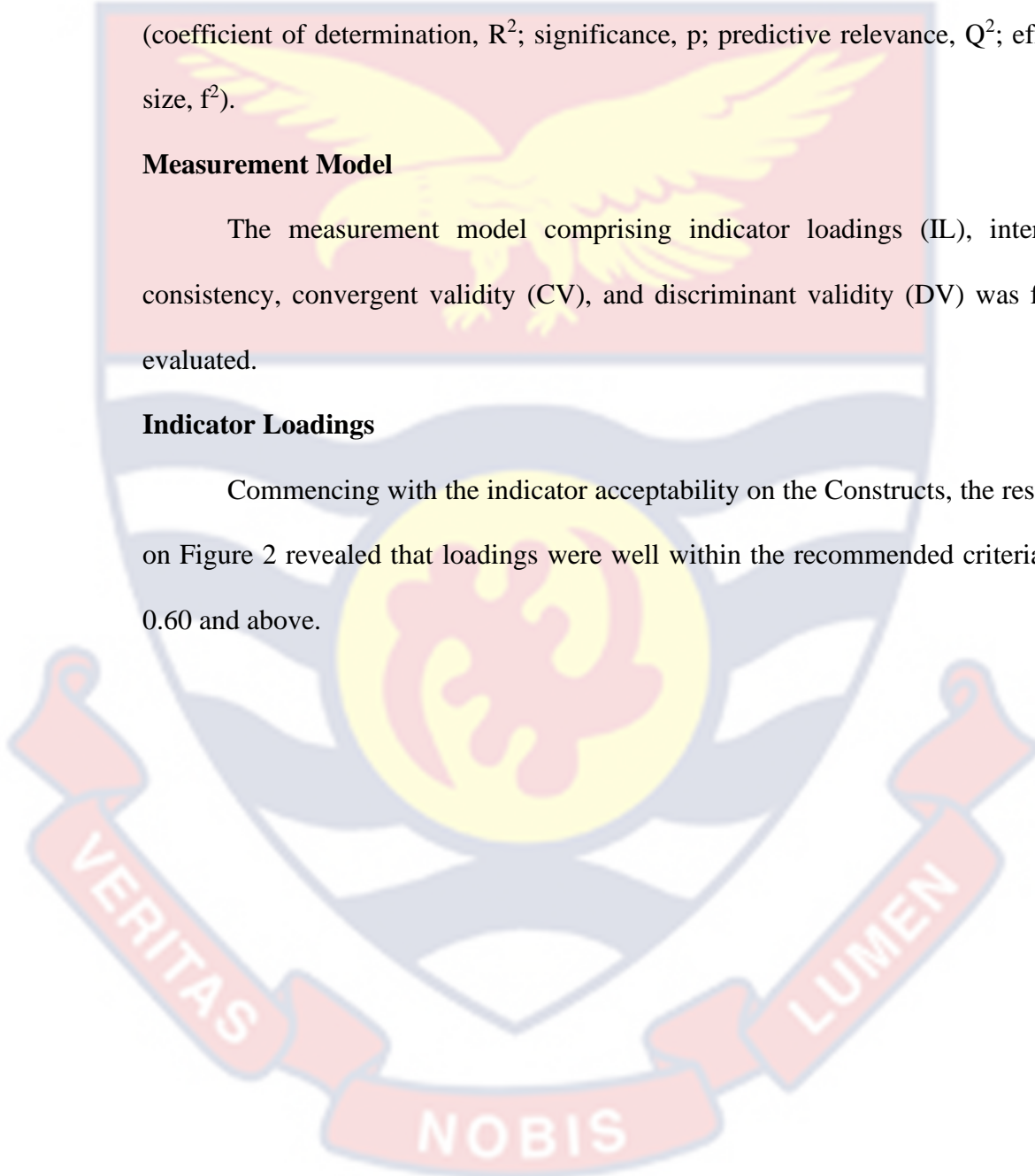

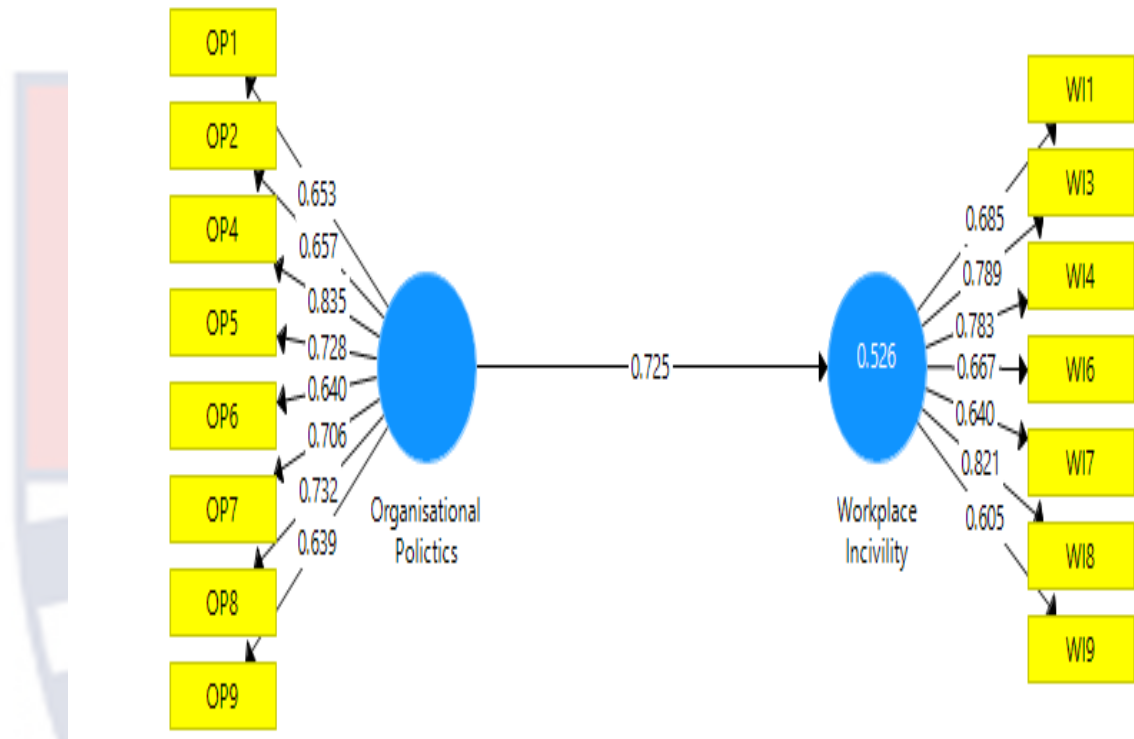

Figure 3: Indicator Loadings Assessment for objective one

Source: Field Data (2022)

From Figure 2, loadings for organizational politics (OP) were between 0.639 – 0.835 while those of workplace incivility (WI) were between 0.605 – 0.821. As a rule of thumb prescribed by Hair et al. (2017), the indicators shown in the figure were retained. The remaining items for OP (OP3, OP10) and WI (WI2, WI5, WI10) were deleted from the model because they failed to meet the threshold or affected overall reliability.

Internal Consistency Reliability, Convergent Validity and Discriminant Validity

The assessment of internal consistency reliability of the constructs was done using the CA, rho_A and CR whiles convergent validity was done using the AVE. The study's DV, which measures the extent to which constructs or variables are distinguished from each other, was assessed using the Heterotrait- Monotrait Ratio (HTMT). Table 4 reports on the summary of the results of the PLS output.

Table 4: Construct Validity and Reliability

	Cronbach's Alpha	rho_A	Composite Reliability	Average Variance Extracted (AVE)
OP	0.852	0.862	0.885	0.726
WI	0.839	0.847	0.880	0.814
Heterotrait-Monotrait Ratio (HTMT)				
		1		2
OP				
WI		0.825		

Notes: OP = Organisational Politics; WI = Workplace Incivility; CA = Cronbach's Alpha; CR = Composite Reliability; CV = Convergent Validity; AVE = Average Variance Extracted.

Source: Field survey (2022)

Although, CR is seen as the best measure of internal consistency, a cursory check at the values of all the other measures shown that the constructs' internal consistency reliability was achieved. Again, the constructs convergent validity was satisfactory because values of AVE were well higher than the minimum 50 percent

threshold. In respect of the DV, the table confirmed that SL and OCB were two distinct constructs as revealed also by the HTMT ratio of < 0.85 cut-off point.

Structural Model

The next table evaluated the structural model and from which inferences were made into the objective of the study. The structural model primarily helped the researcher to draw conclusions on how organizational politics influences workplace incivility, particularly, among staff at the University of Cape Coast. The results of the coefficients (R), R^2 , significance, P, Q^2 and f^2 were presented in Table 5.

Table 5: Structural Model Results for Objective One

	Beta (R)	T Statistics	R^2	Adjusted R^2	Q^2	P- value	F^2
OP->WI	0.725	11.923	0.526	0.521	0.247	0.000	1.109

Notes: R^2 of 0.25, 0.5 and 0.75 is considered as weak, moderate and substantial respectively; Q^2 of 0.02, 0.15 and 0.35 is considered as small, medium and large respectively; f^2 of 0.02, 0.15 and 0.35 is seen as small, medium and large respectively

Source: Field survey (2022)

The results as portrayed in Table 5 indicated that servant leadership has significant positive influence ($R=0.725$; $t=11.923$; $p=0.000$) on the workplace incivility. On the basis of R, the result implies that any unit improvement in the scores of organizational politics will lead to a 0.725 significant increase in workplace incivility in Ghana. Additionally, the result of the R^2 adjusted can be interpreted to mean that 52.1% of variations in workplace incivility was accounted

for by changes in organizational politics in the study, thus, organizational politics is regarded as one of the significant antecedents of workplace incivility. Again, the results shown that the predictive relevance of organizational politics on workplace incivility was moderate ($Q^2=0.247$) testifying that organizational politics makes significant contribution to workplace incivility. The value of the effect size ($f^2=1.109$) further imply that organizational politics has large impact on the R and R2 of workplace incivility.

Organisational politics has appeared as greater associate of civility in the workplace. It is a community process including both functional and dysfunctional sides. In functional roles, organisational policy may permit for a particular degree of flexibility that other structures do not. Even though, it becomes unstable as and when corporate goals, conflict with employees' self-interest. Incivility tends to flourish in a hectic and competitive working atmosphere where political games are quite common as workers attempt to undermine the success of their colleagues in order to boost their position (Salin, 2003; Hourani, Williams, Lattimore, Morgan, Hopkinson, Jenkins & Cartwright, 2018; Lambert, Gordon, Paoline III & Hogan, 2018).

Organizational politics can profoundly influence the dynamics of a workplace, potentially leading to the development of a divisive and toxic culture that nurtures incivility. When politics take center stage, employees may become more focused on individual gains and power struggles rather than the collective success of the organization. This shift in focus can erode trust among team members and create an atmosphere of competition and suspicion. In politically charged

environments, favoritism and nepotism may become prevalent, leading to perceptions of unfairness and unequal opportunities. Employees who feel overlooked or marginalized due to such practices may harbor resentment, fostering a breeding ground for uncivil behaviour. Moreover, when individuals prioritize their own interests over the goals of the team or organization, it can lead to a lack of collaboration and teamwork, further exacerbating tensions and conflicts.

One of the key issues associated with organizational politics is information hoarding. When certain employees withhold crucial information or resources to gain a competitive edge, it can create an atmosphere of secrecy and mistrust. This lack of transparency can fuel frustration and animosity among team members, contributing to workplace incivility. In politically-driven workplaces, some employees may resort to undermining or backstabbing their colleagues to advance their own agendas. This toxic behaviour not only damages individual relationships but can also disrupt team cohesion and productivity. As emotional exhaustion sets in due to the constant stress and uncertainty resulting from organizational politics, employees may become more prone to displaying uncivil behaviours, such as impatience and frustration.

To address workplace incivility effectively, organizations must take proactive steps to promote a healthier and more positive work environment. Transparent communication and fair practices should be encouraged to build trust among employees. Leaders play a vital role in discouraging political behaviours that undermine the organization's values and mission. Organizational leaders can establish clear guidelines and policies that emphasize professionalism and mutual

respect. Additionally, training programs can be implemented to raise awareness about the consequences of incivility and the importance of fostering a supportive workplace culture. By prioritizing employee well-being and promoting a sense of unity and cooperation, organizations can combat the negative impact of organizational politics and create a more harmonious and productive work environment.

Research Objective Two: Effect of Employee Resilience on Workplace Incivility

The second objective of the study analysed the influence employee resilience (ER) has on workplace incivility (WI) of senior staff at the University of Cape Coast in Ghana. The findings on the objective were reported and discussed after assessing the measurement and structural models of the objective. The loadings of each indicator of the constructs were checked using Figure 4 also known as the PLS output extracted.

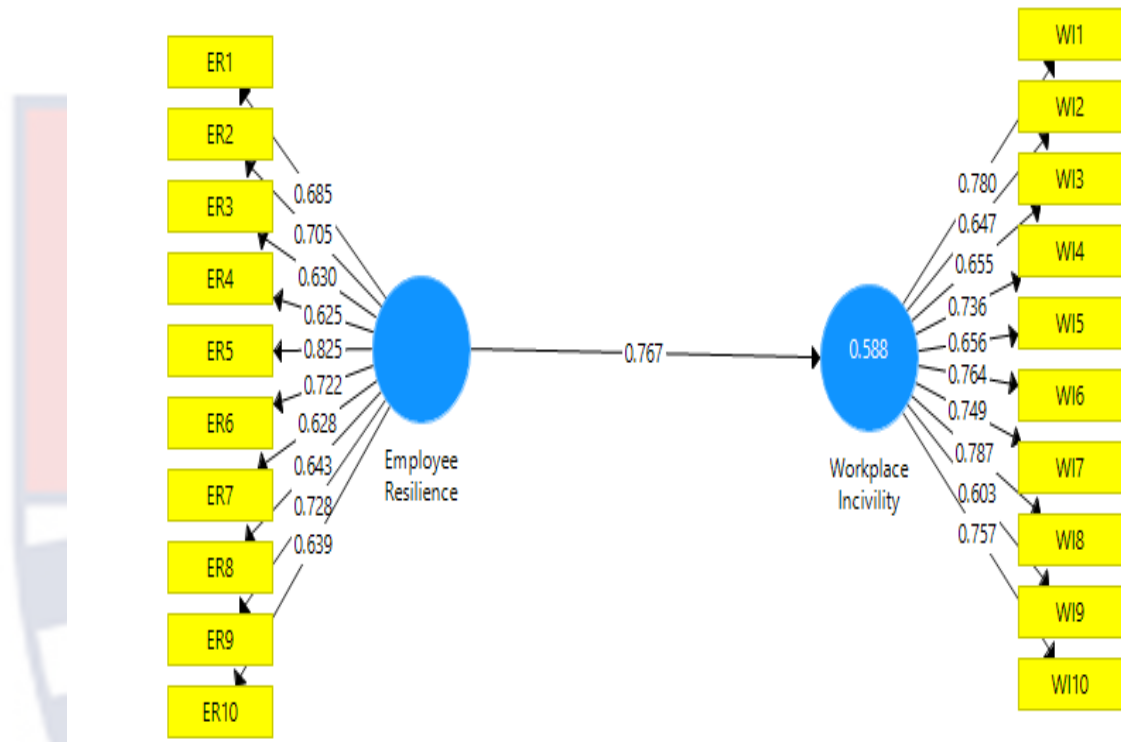

Figure 4: Indicator Loadings Assessment for Objective Two

Source: Field Data (2022)

According to Figure 4, indicator loadings for employee resilience (ER) were within 0.625 – 0.825 while those of workplace incivility (WI) ranged from 0.603 – 0.787. Some of the indicators that loaded below the 0.600 threshold were retained because of the argument raised by Hair et al. (2019) that in circumstances where such items will not affect the overall reliability of the model, they should be maintained. All the indicators were all retained and considered acceptable in terms of its' reliability. Additionally, internal consistency, convergent validity and the discriminant validity of the constructs were assessed using the appropriate values and thresholds displayed in Table 6.

Table 6: Construct Reliability, Validity and Discriminant Validity

	Cronbach's Alpha	rho_A	Composite Reliability	Average Variance Extracted (AVE)
ER	0.874	0.883	0.898	0.570
WI	0.893	0.901	0.913	0.513
Heterotrait-Monotrait Ratio (HTMT)				
		1		2
ER				
WI		0.835		

Source: Field Data (2022)

Results from Table 6 suggest that the model employed in this objective had no internal consistency reliability issues as all measures, CA, rho_A and CR were well within acceptable levels. The constructs' convergent validity was met due to satisfactory values of AVE attained and finally, the table confirms that ER and WI were distinct from each other as demonstrated by the HTMT ratio, $0.835 < 0.850$. Generally, the measurement model was found satisfactory for a good progression to assessing the structural model in next table.

Table 7: The Structural Model Results of Objective Two

	Beta (R)	T Statistics	R ²	Adjusted R ²	Q ²	P-value	F ²
ER->WI	0.767	13.529	0.588	0.584	0.273	0.000	1.429

Source: Field Data (2022)

The results of the structural model as displayed in Table 7 indicated that servant leadership plays significant and positive influential role on public service

motivation ($R=0.767$; $t=13.529$; $p=0.000$; $p<0.05$). All things being equal, a unit increase in the scores of employee resilience will accordingly result in a 0.767 significant improvement in workplace incivility. This is because both the t-statistic ($t=13.529>1.96$) and the p value ($p=0.000<0.05$) which determines the significance of changes in a variable were all within acceptable criteria. Furthermore, the result of coefficient of determination (R^2 adjusted = 0.588) shows that about 58 percent of changes in the workplace incivility was accounted for by changes in employee resilience. Thus, the remaining approximate 42 percent could be attributed to errors or other factors or antecedents not captured in the study. Moreover, the model had moderate predictive relevance between the constructs and a large effect on the R^2 of the workplace incivility (WI).

In the modern workplace, employee resilience stands as a vital and transformative quality that significantly impacts the dynamics of organizations, particularly in the context of addressing workplace incivility. Resilience can be understood as the capacity of an individual to withstand and recover from adversity, adversity, and hardships while maintaining emotional balance and overall well-being. It encompasses a combination of psychological, emotional, and cognitive attributes that enable individuals to navigate challenging circumstances with grace and effectiveness. The presence of employee resilience in a workplace can act as a powerful shield against the negative effects of workplace incivility. Incivility, which encompasses disrespectful, rude, or hostile behaviours among colleagues, can corrode team morale, damage relationships, and ultimately compromise overall productivity. However, when employees exhibit high levels of resilience, they

possess the inner strength and adaptive capabilities to confront incivility head-on, turning potential conflicts into opportunities for growth and collaboration.

Resilient individuals demonstrate the capacity to cope with the emotional toll of workplace incivility without succumbing to burnout or diminished job satisfaction. Instead of being overwhelmed by negative emotions, they channel their energy into finding constructive solutions and maintaining composure even in the face of incivility. This emotional stability allows them to preserve their focus, contribute positively to the team, and enhance their overall well-being despite challenging circumstances. Moreover, employee resilience cultivates a climate of positivity and respect, which contributes to healthier relationships among colleagues. When faced with incivility, resilient individuals are less likely to retaliate with further uncivil behaviour. Instead, they embrace empathy and understanding, responding to incivility with composure and seeking constructive ways to resolve conflicts. This approach sets a powerful example for others, encouraging a ripple effect of respectful communication and positive interactions throughout the organization.

Resilient employees display a remarkable level of adaptability and flexibility when confronted with incivility. Rather than viewing it as a debilitating threat, they perceive it as a challenge to be overcome. This mindset enables them to adjust their responses and behaviours strategically, fostering a more collaborative and harmonious work environment. They actively engage in conflict resolution processes, seek support, and proactively address issues, which not only prevents the escalation of incivility but also promotes a culture of openness and

mutual respect. Organizations can harness the power of employee resilience by investing in resilience-building programs and training initiatives. Providing employees with resources for stress management, emotional intelligence, and conflict resolution equips them with the skills necessary to navigate incivility effectively. Moreover, fostering a supportive and inclusive work culture that values the well-being of employees creates an environment where resilience can flourish naturally.

In conclusion, employee resilience plays a multifaceted and vital role in combating the negative effects of workplace incivility. It empowers individuals to confront challenges with resilience, emotional intelligence, and adaptability, transforming potential conflicts into opportunities for growth and fostering a workplace that thrives on mutual respect and collaboration. Embracing and nurturing employee resilience can lead to a healthier, more productive, and harmonious work environment, ultimately benefiting both the individual and the organization as a whole.

Research Objective Three: Moderating Role of Employee Resilience on the Organisational Politics and Workplace Incivility Relationship

This section sought to analyse the final objective designed to achieve the overall purpose of the study. The final objective examined the moderating role of employee resilience in the relationship between organizational politics and workplace incivility of senior staff of the University of Cape Coast in Ghana. Thus, the study hypothesised that employee resilience moderates the nexus between organizational politics and workplace incivility. The inclusion of employee

resilience in the nexus was again driven by the quest to determine how it could change the direction and strength of the OP – WI link. Prior to the analysis, the measurement model was evaluated based on the recommended standards of indicator reliability, internal consistency, convergent validity and discriminant validity.

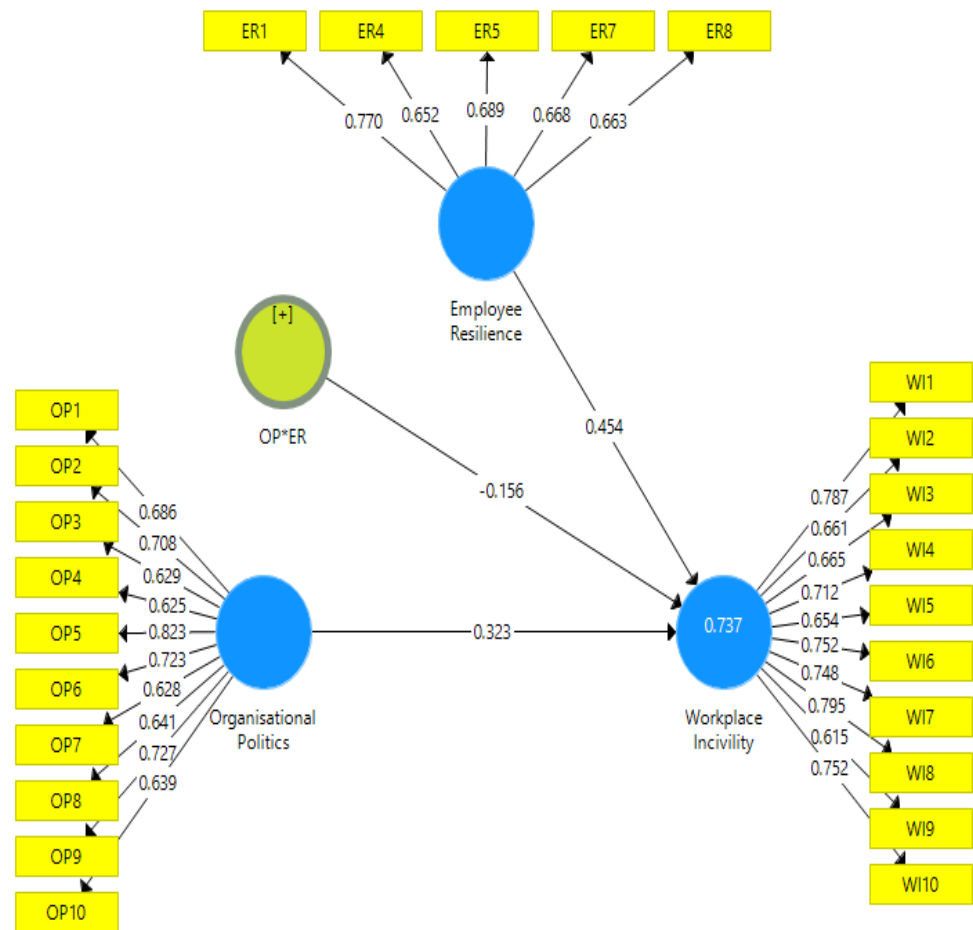

Figure 5: Item loadings Assessment for Objective Three

Source: Field Data (2022)

Loadings on the indicators of the organizational politics and workplace incivility constructs as depicted in Figure 5 show that the items retained for each of the constructs were good and appropriate for the measurement model.

Table 8: Construct Reliability, Validity and Discriminant Validity

	Cronbach's Alpha	rho_A	Composite Reliability	Average Variance Extracted (AVE)
ER	0.727	0.742	0.819	0.511
OP*ER	0.962	1.000	0.964	0.617
OP	0.874	0.883	0.898	0.501
WI	0.893	0.896	0.913	0.514

Heterotrait-Monotrait Ratio (HTMT)

	1	2	3	4
ER				
OP*ER	0.584			
OP	0.651	0.524		
WI	0.752	0.584	0.835	

Source: Field Data (2022)

Also, the CA, rho_A and CR which serve as measure of internal consistency reliability of the constructs were acceptable in the study. A close observation of the values of CA reveal that the score was well above the 0.70 threshold. Same was seen of the rho_A and CR, all of which, the scores loaded above the cut-off points (>0.708: Table 8). It was noted further that the 50 percent minimum score recommended for AVE for the achievement of convergent validity or mutual relationships between the constructs was met. This is because, the AVEs of

organizational politics, workplace incivility and employee resilience were well above 0.50 threshold (Table 8). The model showed that issues of discriminant validity were not recorded ($HTMT < 0.85$: Table 8). After assessing the measurement model, the way was opened for the researcher to adopt the structural model for analysing the objective of the study. Results were summarised in Table 9.

Table 9: Structural Model Results for Research Objective Three

	Beta (R)	T- Statistics	R ²	Adjusted R ²	Q ²	P- value	F ²
WI			0.737	0.729	0.344		
ER->WI	0.454	5.197				0.000	0.365
OP*ER->WI	-0.156	1.638				0.102	0.125
OP->WI	0.323	3.057				0.002	0.183

Source: Field survey (2022)

The results in Table 9 showed that, first, organizational politics has a significant positive ($R=0.323$; $t=3.057$; $p=0.002$) link with workplace incivility (WI) holding the interacting term or moderator employee resilience constant, which, connotes also that the effect of the relationship per the effect size ($f^2=0.183$) statistic was large. Also, employee resilience (ER) demonstrated a significant positive nexus with workplace incivility (WI) ($R=0.454$; $t=5.197$; $p=0.000$), suggesting that a unit increase in employee resilience will lead to a 0.454 increase in workplace incivility (WI) of senior staff at the University of Cape Coast with large effect or impact ($f^2=0.365$). In a similar vein, when employee resilience is

reduced, it will lead to a decrease in the workplace incivility of senior staff by same scores.

However, the results of the moderation in the structural model revealed a negative insignificant relationship between organizational politics and workplace incivility (WI) ($R = -0.156$; $t = 1.638$; $p = 0.102$: Table 9) when employee resilience interacted with organizational politics construct. As portrayed also by the f^2 (0.125: Table 9), it stands to buttress the point that employee resilience does not play a role in contributing to the R^2 value and Q^2 values in the model or have any effect on the strength and direction of the organizational politics and workplace incivility relationship. This leads to the conclusion in the study that employee resilience does not moderate the nexus between organizational politics and workplace incivility of senior staff of the University of Cape Coast in Ghana. Therefore, hypothesis three was faulted and failed to be accepted.

Empirical finding evidence to acknowledge the second findings argued that employee resilience has made a substantial contribution to workplace incivility. These findings are reinforced by previous research that the mechanism of employee resilience, involving high and low-ranking workers who are engaged in a battle for personal advantages, has begun to adapt to the system. Findings show that workers who does not have the ability to manipulate become sufferers of political games instead of taking advantage of them. However, higher-ranking workers who have legal rights have the right to a form of social deference and enforcement. They are in a stronger position not just to initiate and control political behaviours but also to gain from them (Aquino, Galperin & Bennett, 2004; Ash-Houchen & Lo, 2018).

Chapter Summary

This chapter has presented the results of the objectives considered in this study. The demographic data showed that respondents were from all age levels, academic qualifications, years worked, marital status, and employment status within the organisation. Concerning the first objective, the study showed that organisational politics had a significant but negative effect on workplace incivility. The second objective also showed that employee resilience has a positive influence on workplace incivility. The final objective showed that employee resilience mediates the relationship between organisational politics and workplace incivility.



CHAPTER FIVE

SUMMARY, CONCLUSIONS AND RECOMMENDATIONS

Introduction

The study sought to examine the influence of organisational politics on workplace incivility: the moderating role of employee resilience of senior staff at the University of Cape Coast, Ghana. The previous chapter provided information in respect of the findings and discussions made. This chapter presents information relating to the summary of the key findings, the conclusions drawn in respect of the specific research objectives and that of the recommendations offered in respect of the study.

Summary of Findings

The main aim of this study was to examine the influence of organisational politics on workplace incivility: the moderating role of employee resilience of senior staff at the University of Cape Coast, Ghana. Specifically, the study sought to; investigate the effect of organisational politics on workplace incivility of senior staff at the University of Cape Coast; to examine the effect of employee resilience on workplace incivility of senior staff at the University of Cape Coast and; to examine the moderating role of employee resilience on the relationship between organisational politics and workplace incivility among senior staff at the University of Cape Coast.

To help achieve these objectives, three supporting research questions were formulated geared towards answering the objectives accordingly. The study employed partial least squares structural equation modelling as the main statistical

technique for the analysis. From a population of 1570 senior staff from the University of Cape Coast, 310 were sampled, using the simple random technique, the Microsoft Excel random number generation was used to randomly select respondents for the study. In total, 293 valid responses were obtained from the senior staff at the University of Cape Coast. The study began with a pre-test with 20 senior staff at the University of Cape Coast, UCC. Following the success, a self-administered questionnaire based on scales from reliable and on extensive literature was administered to the respondents. This was done to avoid common method bias. The instrument centered on characteristics of the respondents as well as the variables considered in this study.

The demographic information on respondents was analysed using descriptive statistics (Frequencies and percentages). The three main objectives of this study were analysed using partial least squares structural equation modelling techniques with the aid of the SMART PLS version 3.0, while the descriptive were processed with the SPSS Version 26. An alpha level of 0.05 was used for all tests of significance. Three research questions were developed to answer the purpose of the study. The major findings as they related to the specific objectives of the study have been summarised below.

Key Findings of the Study

With respect to the objectives of the study, these were the outcomes of the study.

1. The first objective examined the effect of organisational politics on workplace incivility of senior staff at the University of Cape Coast. The

results showed that, organisational politics had a statistically significant but negative (path= -0.007, $p < 0.05$) variance in workplace incivility among senior staff at the University of Cape Coast.

2. The second objective examined the effect of employee resilience on workplace incivility among senior staff at the University of Cape Coast. The results showed that, employee resilience accounts for a statistically significant variance in workplace incivility among senior staff at the University of Cape Coast. The contribution of employee resilience to predicting the 72.5% change in workplace incivility shows that, organisational politics makes a statistically significant and positive contribution.
3. Objective three assessed the moderating effect of employee resilience in the relationship between organisational politics and workplace incivility among senior staff at the University of Cape Coast. The results showed that, employee resilience partially mediate the predictive relationship between organisational politics and workplace incivility among senior staff at the University of Cape Coast.

Conclusions

The conclusions are drawn based on the findings of the study;

1. With respect to the first objective, it is concluded that organisational politics are only beneficial to minimize the adverse effect on incivility at the workplace when it is assumed to be healthy, hence, to enhance productivity, performance and growth. Organisational politics has

appeared as greater associate of civility in the workplace. It is a community process including both functional and dysfunctional sides. In functional roles, organisational policy may permit for a particular degree of flexibility that other structures do not. Even though, it becomes unstable as and when corporate goals, conflict with employees' self-interest. In conclusion, incivility tends to flourish in a hectic and competitive working atmosphere where political games are quite common as workers attempt to undermine the success of their colleagues in order to boost their position.

2. With respect to the second objective, this study concludes that employee resilience among senior staff at the University of Cape Coast has a significant influence on workplace incivility. It can further be concluded that, a positive approach to employee resilience within the institution, can promote healthy competition among senior staff contributing to improved performance and growth. Likewise, the adverse may also tend to create an uncondusive climate or setting at the workplace resulting to poor performance among senior staff.
3. With respect to the final objective, this study concludes that employee resilience does partially mediate the relationship between organisational politics and workplace incivility. The findings lead to the conclusion that, holding other factors and variables constant, the system of resilience adopted by employees may be dependent on the kind or type of organisational politics within the workplace.

Recommendations

The following recommendations are based on the conclusions drawn from this study;

1. With respect to the objective one, the study found that, organisational politics has a significant but negative effect on workplace incivility. It is recommended that, conscious managerial effort needs to be expended to create, maintain and promote a healthy political climate within the organisation that builds the level of performance among senior staff at the University of Cape Coast, resulting in a conducive working environment necessary for organisational growth.
2. Moving on, the study found from the objective two that, employee resilience has a significant and positive relationship with workplace incivility. Employee resilience can be promoted in any working environment. Hence, it is recommended that, the development of resilience training programmes would advance the awareness of the influence of organisational politics in the development of employee resilience and workplace incivility. Modesty can be taught and established.
3. The final objective of the study established the fact that, employee resilience mediates the relationship between organisational politics and incivility in the workplace. It is recommended that management of the University of Cape Coast, should pay more attention to improving the resilience of workers. To achieve this, it is suggested that, some actions

taken by the management like building trust and ability among employee to meet the challenges, promoting employee to give solution to the problem, giving more opportunity for learning and growth, promoting meditation and yoga to keep emotion calm and in control etc.

Suggestions for Further Research

The current study sought to argue out the variables under discussions on from the views of a category of staffing within one educational institution in Ghana. The study is performed on a small sample size in a single culture where the cultural background differs across the region. It is therefore proposed that future studies be conducted to assess the generalizability of current findings in other cultures. Although several other factors also influence organisational politics and employee resilience that is not addressed in this study. Future studies may empirically test the proposed non-linear relationship between these variables after incorporating other factors.

REFERENCES

- Abbas, S. R., & Raja, V. (2014). Moderating role of employee motivation for training, commitment, retention, and performance in higher education institutions. *Problems and Perspectives in Management*, 19(3), 95.
- Adams, J. S. (1963). Towards an understanding of inequity. *The journal of abnormal and social psychology*, 67(5), 422.
- Al-Aborrow, K., Alberdi, A., Alef, W., Asada, K., Azulay, R., Baczko, A. K., ... & Ramakrishnan, V. (2018). First M87 event horizon telescope results. IV. Imaging the central supermassive black hole. *The Astrophysical Journal Letters*, 875(1), L4.
- Al-Madadha, M., Al-Adwan, W., & Zakzouk, D. (2021). Combined effects of perceived politics and psychological capital on job satisfaction, turnover intentions, and performance. *Journal of management*, 40(7), 1813-1830.
- Alola, H., Zhang, Z., Zhao, J., Yang, Q., Drory, A., & Vigoda-Gadot, E. (2021). Organizational politics and human resource management: A typology and the Israeli experience. *Human Resource Management Review*, 20(3), 194-202.
- Amehein, C., Trafimow, Y., & Greenland, B. (2019). Clinical features of patients infected with 2019 novel coronavirus in Wuhan, China. *The lancet*, 395(10223), 497-506.
- Arogundade, G. N., Arogundade, G. N., & Gbabijo, Z. (2016). Ethical considerations in organizational politics: Expanding the perspective. *Journal of Business Ethics*, 93(4), 497-517.

Ashforth, B. (1994). Petty tyranny in organizations. *Human relations*, 47(7), 755-778.

Ashiru, R. C., & Ariyo, P. D. (2015). A schema-theoretic view of basic processes in reading comprehension. *Interactive approaches to second language reading*, 37-55.

Babbie, C., (2010). 6-month consequences of COVID-19 in patients discharged from hospital: a cohort study. *The Lancet*, 397(10270), 220-232.

Beugre, E., & Liverpool, T. M. (2006). Impact of organisational politics on job dissatisfaction and turnover intention: An application of social exchange theory on employees working in Zimbabwean small and medium enterprises (SMEs). *Journal of Applied Business Research (JABR)*, 32(3), 857-870.

Bishop, R., Howes, J. C., Grandey, A. A., & Toth, P. (2006). The relationship of organizational politics and support to work behaviours, attitudes, and stress. *Journal of Organizational Behaviour: The International Journal of Industrial, Occupational and Organizational Psychology and Behaviour*, 18(2), 159-180.

Bonito, A. (2012). Perceived political climate and job attitudes. *Organization studies*, 14(1), 59-71.

Bouckenooghe, D., Zafar, A., & Raja, U. (2015). How ethical leadership shapes employees' job performance: The moderating roles of goal congruence and psychological capital. *Journal of Business Ethics*, 129(2), 251-264.

Brandon, U., & Seldman, N. (2004). A cross-sectional survey on consequences of nurses' burnout: moderating role of organizational politics. *Journal of advanced nursing*, 72(8), 1838-1850.

Brehm, G., & Brehm, S. (1981). Paradoxical leadership in public sector organisations: Its role in fostering employee resilience. *Australian Journal of Public Administration*, 79(1), 93-110.

Brown, R., & Levinson, D. P. (1987). A popcorn metaphor for employee aggression.

Butcher, M. A., & Clarke, T. R. (2006). Initial genome sequencing and analysis of multiple myeloma. *Nature*, 471(7339), 467-472.

Chahar, G. N., & Hatwal, A. W. (2021). The norm of reciprocity: A preliminary statement. *American sociological review*, 161-178.

Chahar, R. A., & Hatwal, J. H. (2021). Workplace violence and workplace aggression: Evidence on their relative frequency and potential causes. *Aggressive Behaviour: Official Journal of the International Society for Research on Aggression*, 22(3), 161-173.

Chen, P., & Wang, V. (2019). Perceived organizational support and employee diligence, commitment, and innovation. *Journal of applied psychology*, 75(1), 51.

Cheney, G., Christensen, L. T., Conrad, C., & Lair, D. J. (2004). Corporate rhetoric as organizational discourse. *The Sage handbook of organizational discourse*, 79-103.

- Chhabra, K. (2021). Organisational politics and their effect on workplace learning. *European Scientific Journal*.
- Chinelato, H., Zhang, Z., Zhao, J., Yang, Q., Cacciattolo, K. (2020). Organisational politics: The positive & negative sides. *European Scientific Journal*, 11(1).
- Chircop, S. (2008). Lies, damned lies and organisational politics. *Industrial and commercial training*.
- Cortina, L. M., Kabat-Farr, D., Magley, V. J., & Nelson, K. (2017). Researching rudeness: The past, present, and future of the science of incivility. *Journal of Occupational Health Psychology*, 22(3), 299.
- Crawford, H., Zhang, Z., Zhao, J., Yang, Q., & Carter, C. S. (2019). Neuroendocrine perspectives on social attachment and love. *Psychoneuroendocrinology*, 23(8), 779-818.
- Creswell, S., & Clarke, P. M. (2017). Immature low-density neutrophils exhibit metabolic flexibility that facilitates breast cancer liver metastasis. *Cell reports*, 27(13), 3902-3915.
- De Clercq, G. N., Haq, G. N., Azeem, A. W., & Ahmad, N. (2019). The norm of reciprocity: A preliminary statement. *American sociological review*, 161-178.
- Drucker, Y. (2009). Reduction and functional exhaustion of T cells in patients with coronavirus disease 2019 (COVID-19). *Frontiers in immunology*, 827.
- Engstrom, T. M. (2001). Impact of organisational politics on job dissatisfaction and turnover intention: An application of social exchange theory on

employees working in Zimbabwean small and medium enterprises (SMEs). *Journal of Applied Business Research (JABR)*, 32(3), 857-870.

Ferris, H., Zhang, Z., Zhao, J., Yang, Q., Crawford, J., & Brownlie, I. (1989). *Brownlie's principles of public international law*. Oxford University Press, USA.

Giacalone, R. A., & Greenberg, J. (Eds.). (1997). *Antisocial behaviour in organizations*. Sage.

Hochwarter, H., Witt, Z., & Kacmar, N. (2000). A cross-sectional survey on consequences of nurses' burnout: moderating role of organizational politics. *Journal of advanced nursing*, 72(8), 1838-1850.

Huang, D. S., & Lin, B. S. (2019). Partially spatially coherent digital holographic microscopy and machine learning for quantitative analysis of human spermatozoa under oxidative stress condition. *Scientific reports*, 9(1), 1-10.

Kacmar, K. M., & Baron, R. A. (1999). Organizational politics. *Research in human resources management*, 1, 1-39.

Kacmar, K. M., & Carlson, D. S. (1997). Further validation of the perceptions of politics scale (POPS): A multiple sample investigation. *Journal of management*, 23(5), 627-658.

Karim, R. (2021). Hybrid web recommender systems. *The adaptive web*, 377-408.

Keesler, P. R., & Fukui, J. (2020). Rudeness at work: Impulse over restraint. *Public personnel management*, 30(4), 457-465.

Khalaf, N. A., Shakya, A. K., Al-Othman, A., El-Agbar, Z., & Farah, H. (2008). Antioxidant activity of some common plants. *Turkish Journal of Biology*, 32(1), 51-55.

Kheng, M., Ali, H. Y., Anwar, S., Iqbal, A., Iqbal, M. B., Suleman, N., ... & Haris-ul-Mahasbi, M. (2013). Impact of organizational politics on employee work outcomes in higher education institutions of Pakistan: Moderating role of social capital. *South Asian Journal of Business Studies*.

Khuwaja, S., Zhang, H., Zhang, Z., Zhao, J., & Yang, Q., (2018). What's in an eye roll? It is time we explore the role of workplace incivility in healthcare. *Israel journal of health policy research*, 7(1), 1-3.

Khuwaja, U., Ahmed, K., Abid, G., & Adeel, A. (2020). Leadership and employee attitudes: The moderating role of perception of organizational politics. *Cogent Business & Management*, 7(1), 1720066.

Kinney, G. M. L. (1995). Solid mechanics and its applications. (*No Title*).

Kirk, G., & Barblett, L. (2022). Implementing the National Quality Standard in schools: leadership that motivates improvement initiatives through psychological ownership. *The Australian Educational Researcher*, 49(2), 367-385.

Knezović, E., & Drkić, A. (2020). Innovative work behaviour in SMEs: the role of transformational leadership. *Employee Relations: The International Journal*.

Kothari, J. G. (2004). Research electronic data capture (REDCap)—a metadata-driven methodology and workflow process for providing translational

research informatics support. *Journal of biomedical informatics*, 42(2), 377-381.

Kumar, A. A. (2011). Customer incivility as a social stressor: the role of race and racial identity for service employees. *Journal of occupational health psychology*, 14(1), 46.

Ladebo, O. J. (2006). Perceptions of organisational politics: Examination of a situational antecedent and consequences among Nigeria's extension personnel. *Applied Psychology*, 55(2), 255-281.

Langley, D. J., van Doorn, J., Ng, I. C., Stieglitz, S., Lazovik, A., & Boonstra, A. (2021). The Internet of Everything: Smart things and their impact on business models. *Journal of Business Research*, 122, 853-863.

Langley, S., Yuan, F., Zhang, H., Zhang, Z., Zhao, J., Yang, Q., ... & Chen, X. (2021). Characterization of the wheat-*Psathyrostachys huashania* Keng 2Ns/2D substitution line H139: A novel germplasm with enhanced resistance to wheat take-all. *Frontiers in plant science*, 11, 233.

Lewandowsky, H., Zhang, Z., Zhao, J., Yang, Q., & Baron, R. A. (2020). The cognitive perspective: a valuable tool for answering entrepreneurship's basic "why" questions. *Journal of business venturing*, 19(2), 221-239.

Lewandowsky, S., Smillie, L., Garcia, D., Hertwig, R., Weatherall, J., Egidy, S., ... & Leiser, M. (2020). Technology and democracy: Understanding the influence of online technologies on political behaviour and decision-making.

Li, H., Zhang, Z., Zhao, J., Yang, Q., Buchanan, D., & Badham, R. (2020). *Power, politics, and organizational change*. Sage.

Lim, S., Cortina, L. M., & Magley, V. J. (2008). Personal and workgroup incivility: impact on work and health outcomes. *Journal of applied psychology*, 93(1), 95.

Lim, S., Cortina, L. M., & Magley, V. J. (2008). Personal and workgroup incivility: impact on work and health outcomes. *Journal of applied psychology*, 93(1), 95.

Liu, J., Zhou, J., & Che, R. (2019). Perceived organizational support and psychological contracts: A theoretical integration. *Journal of Organizational Behaviour: The International Journal of Industrial, Occupational and Organizational Psychology and Behaviour*, 24(5), 491-509.

Loh, J. M., & Loi, N. (2018). Tit for tat: Burnout as a moderator between workplace incivility and instigated workplace incivility. *Asia-Pacific Journal of Business Administration*.

Loh, J. M., & Loi, N. (2018). Tit for tat: Burnout as a moderator between workplace incivility and instigated workplace incivility. *Asia-Pacific Journal of Business Administration*.

Lohr, J. (2019). Relationships. *Transparency, and Evaluation: The Implications for Public Relations available at http://www.euprera.org/_webdata/downloads/48--evaluation--julia.pdf*.

- Lugaz, N., Salman, T. M., Winslow, R. M., Al-Haddad, N., Farrugia, C. J., Zhuang, B., & Galvin, A. B. (2020). Inconsistencies between local and global measures of CME radial expansion as revealed by spacecraft conjunctions. *The Astrophysical Journal*, 899(2), 119.
- Malik, L. A., Bashir, A., Qureshi, A., & Pandith, A. H. (2019). Detection and removal of heavy metal ions: a review. *Environmental Chemistry Letters*, 17(4), 1495-1521.
- Mao, R., Fasolo, P., & Davis-LaMastro, V. (2019). Perceived organizational support and employee diligence, commitment, and innovation. *Journal of applied psychology*, 75(1), 51.
- March, A. E. (2010). Workplace incivility and employee sleep: The role of rumination and recovery experiences. *Journal of occupational health psychology*, 24(2), 228.
- Marks, G. (1996). An actor-centred approach to multi-level governance. *Regional & Federal Studies*, 6(2), 20-38.
- Martin, E. (1996). Organizational politics and human resource management: A typology and the Israeli experience. *Human Resource Management Review*, 20(3), 194-202.
- Martin, R. A. (1996). *Antisocial behaviour in organizations*. Sage.
- Martin, S. L. (2006). Development of a measure of workplace deviance. *Journal of applied psychology*, 85(3), 349.
- Maxwell, K. (2012). Impact of dietary polyphenols on carbohydrate metabolism. *International journal of molecular sciences*, 11(4), 1365-1402.

McDaniel, P. R., & Gates, J. (1996). Rudeness at work: Impulse over restraint. *Public personnel management*, 30(4), 457-465.

Meisler, B., Jain, S. R., & Hatwal, V. (2019). Moderating role of employee motivation for training, commitment, retention, and performance in higher education institutions. *Problems and Perspectives in Management*, 19(3), 95.

Mendez-Villanueva, A., Bishop, D., & Hamer, P. (2006). Activity profile of world-class professional surfers during competition: A case study. *The Journal of Strength & Conditioning Research*, 20(3), 477-482.

Mintzberg, H. (1985). The organization as political arena. *Journal of management studies*, 22(2), 133-154.

Mintzberg, H., & Waters, J. A. (1985). Of strategies, deliberate and emergent. *Strategic management journal*, 6(3), 257-272.

Mishra, N., & Alok, J. G. (2011). Research electronic data capture (REDCap)—a metadata-driven methodology and workflow process for providing translational research informatics support. *Journal of biomedical informatics*, 42(2), 377-381.

Mishra, P., & Kodwani, A. D. (2019). Moderating role of employee engagement on conflict-politics relationship. *Benchmarking: An International Journal*.

Moosavi, M. (2011). Impact of organizational politics on employee work outcomes in higher education institutions of Pakistan: Moderating role of social capital. *South Asian Journal of Business Studies*.

- Morris, K. M. (1996). Perceptions of organizational politics. *Journal of management*, 18(1), 93-116.
- Mullen, P. E., Martin, J. L., Anderson, J. C., Romans, S. E., & Herbison, G. P. (1996). The long-term impact of the physical, emotional, and sexual abuse of children: A community study. *Child abuse & neglect*, 20(1), 7-21.
- Mullen, P. E., Martin, J. L., Anderson, J. C., Romans, S. E., & Herbison, G. P. (1996). The long-term impact of the physical, emotional, and sexual abuse of children: A community study. *Child abuse & neglect*, 20(1), 7-21.
- Muller, J. E., Stone, P. H., Turi, Z. G., Rutherford, J. D., Czeisler, C. A., Parker, C., ... & MILIS Study Group*. (1985). Circadian variation in the frequency of onset of acute myocardial infarction. *New England Journal of Medicine*, 313(21), 1315-1322.
- Mykkanen, S. (2010). Lies, damned lies and organisational politics. *Industrial and commercial training*.
- Namin, B. H., Øgaard, T., & Røislien, J. (2021). Workplace incivility and turnover intention in organizations: A meta-analytic review. *International Journal of Environmental Research and Public Health*, 19(1), 25.
- Näswall, K., Malinen, S., Kuntz, J., & Hodliffe, M. (2019). Employee resilience: Development and validation of a measure. *Journal of Managerial Psychology*.
- Neuman, D. (2004). SARS-CoV-2 variants and ending the COVID-19 pandemic. *The Lancet*, 397(10278), 952-954.

Neuman, J. H., & Baron, R. A. (1997). Aggression in the workplace. *Antisocial behaviour in organizations*, 37, 67.

Neuman, K. C., & Block, S. M. (2004). Optical trapping. *Review of scientific instruments*, 75(9), 2787-2809.

Ni, W., Yao, S., Zhou, Y., Liu, Y., Huang, P., Zhou, A., ... & Li, J. (2019). Long noncoding RNA GAS5 inhibits progression of colorectal cancer by interacting with and triggering YAP phosphorylation and degradation and is negatively regulated by the m6A reader YTHDF3. *Molecular cancer*, 18(1), 1-20.

Nyikayaramba, M. M. M., & Mutimadye, M. A. (2014). Organizational citizenship behaviour role in moderating the effect of transformational leadership on organizational performance in gold industry of Saudi Arabia. *Business: Theory and Practice*, 22(1), 39-54.

Okeke, G. N., & Mbah, A. P. S. I. (2019). Organisational politics and employee performance: A Study of Selected Tertiary Institutions in Anambra State, Nigeria. *Global Journal of Education, Humanities & Management Sciences*, 1(2).

O'Leary-Kelly, A. M., Griffin, R. W., & Glew, D. J. (1996). Organization-motivated aggression: A research framework. *Academy of management review*, 21(1), 225-253.

Olowu, W. A., Niang, A., Osafo, C., Ashuntantang, G., Arogundade, F. A., Porter, J., ... & Luyckx, V. A. (2016). Outcomes of acute kidney injury in children

and adults in sub-Saharan Africa: a systematic review. *The Lancet Global Health*, 4(4), e242-e250.

Organ, D. W. (1988). *Organizational citizenship behaviour: The good soldier syndrome*. Lexington books/DC heath and com.

Othman, R. (2008). Organisational politics: The role of justice, trust and job ambiguity. *Singapore management review*, 30(1), 43-54.

Pallant, C. E. (2016). The case for emotional intelligence in organizational research. *The academy of management review*, 28(2), 195-197.

Paul, K. (2018). Whitewashing Britain. In *Whitewashing Britain*. Cornell University Press.

Pearson, G. N., & Porath, Z. (2005). Ethical considerations in organizational politics: Expanding the perspective. *Journal of Business Ethics*, 93(4), 497-517.

Perlow, R., & Latham, L. L. (1993). Relationship of client abuse with locus of control and gender: A longitudinal study in mental retardation facilities. *Journal of Applied Psychology*, 78(5), 831.

Pfeffer, J. (1981). Understanding the role of power in decision making. *Power in organizations*, 404-423.

Poon, J. M. (2003). Situational antecedents and outcomes of organizational politics perceptions. *Journal of managerial psychology*.

Potwarka, G. N., Snelgrove, G. N., Drewery, M. S., Bakhsh, M. S., & Wood, J. (2019). Towards a multi-foci approach to workplace aggression: A meta-

analytic review of outcomes from different perpetrators. *Journal of Organizational Behaviour*, 31(1), 24-44.

Rahman, B. (2017). Clinical features of patients infected with 2019 novel coronavirus in Wuhan, China. *The lancet*, 395(10223), 497-506.

Rego, G., Smith, M. E., Breneman, T., & Vilgalys, R. (2017). Assessing ectomycorrhizal fungal spore banks of truffle producing soils with pecan seedling trap-plants. *Plant and Soil*, 356(1), 357-366.

Reio, T. G., & Trudel, J. (2013). Workplace incivility and conflict management styles: Predicting job performance, organizational commitment and turnover intent. *International Journal of Adult Vocational Education and Technology (IJAVET)*, 4(4), 15-37.

Rizaev, I. (2021). Liberalization of the social system: constructive and destructive aspects. *TRANS Asian Journal of Marketing & Management Research*, 10(4), 58-64.

Roberts, E. (1985). Organizational politics and human resource management: A typology and the Israeli experience. *Human Resource Management Review*, 20(3), 194-202.

Robinson, G. N., & Bennet, Z. (1995). Ethical considerations in organizational politics: Expanding the perspective. *Journal of Business Ethics*, 93(4), 497-517.

Robinson, S. L., & Bennett, R. J. (1995). A typology of deviant workplace behaviours: A multidimensional scaling study. *Academy of management journal*, 38(2), 555-572.

Rovail, C., Huang, L., Wang, Y., Li, X., Ren, L., Gu, X., ... & Cao, B. (2013). 6-month consequences of COVID-19 in patients discharged from hospital: a cohort study. *The Lancet*, 397(10270), 220-232.

Salman, S. O., Iyabo, A. S., Adeshina, A. T., & Olajide, A. O. (2020). Organisational politics—causes and effects on organisation and employees. *International journal of business, economics and management*, 2(9), 204-208.

Samma, M., Zhao, Y., Rasool, S. F., Han, X., & Ali, S. (2020, November). Exploring the relationship between innovative work behaviour, job anxiety, workplace ostracism, and workplace incivility: empirical evidence from small and medium sized enterprises (SMEs). In *Healthcare* (Vol. 8, No. 4, p. 508). MDPI.

Sapir, D. (1927). SARS-CoV-2 variants and ending the COVID-19 pandemic. *The Lancet*, 397(10278), 952-954.

Saunders, C., Thornhill, Y., & Lewis, S. (2007). The role of co-workers' solidarity as an antecedent of incivility and deviant behaviour in organizations. *Deviant Behaviour*, 37(8), 861-876.

Schermerhorn Jr, J. R., Osborn, R. N., Uhl-Bien, M., & Hunt, J. G. (2011). *Organizational behaviour*. John Wiley & sons.

Schoenhagen, P., Ziada, K. M., Vince, D. G., Nissen, S. E., & Tuzcu, E. M. (2001). Arterial remodeling and coronary artery disease: the concept of “dilated” versus “obstructive” coronary atherosclerosis. *Journal of the American College of Cardiology*, 38(2), 297-306.

Shepherd, N. G., Hodgkinson, G. P., Mooi, E. A., Elbanna, S., & Rudd, J. M. (2020). Political behaviour does not (always) undermine strategic decision making: Theory and evidence. *Long Range Planning*, 53(5), 101943.

Shim, J. K. (2010). Cultural health capital: a theoretical approach to understanding health care interactions and the dynamics of unequal treatment. *Journal of health and social behaviour*, 51(1), 1-15.

Shim, J. K. (2010). Cultural health capital: a theoretical approach to understanding health care interactions and the dynamics of unequal treatment. *Journal of health and social behaviour*, 51(1), 1-15.

Simmons, F. B., Mongeon, C. J., Lewis, W. R., & Huntington, D. A. (1964). Electrical stimulation of acoustical nerve and inferior colliculus: Results in man. *Archives of Otolaryngology*, 79(6), 559-567.

Smith, R. D., Prévot, M. S., Fagan, R. D., Zhang, Z., Sedach, P. A., Siu, M. K. J., ... & Berlinguette, C. P. (2013). Photochemical route for accessing amorphous metal oxide materials for water oxidation catalysis. *Science*, 340(6128), 60-63.

Sohn, T., Seo, J., & Moon, J. (2003, October). A study on the covert channel detection of TCP/IP header using support vector machine. In *International Conference on Information and Communications Security* (pp. 313-324). Springer, Berlin, Heidelberg.

Soieb, A. Z. M., Othman, J., & D'Silva, J. L. (2013). The effects of perceived leadership styles and organizational citizenship behaviour on employee

engagement: The moderating role of conflict management. *International Journal of Business and Management*, 8(8), 91.

Souki, G. Q., Chinelato, F. B., & Gonçalves Filho, C. (2021). Sharing is entertaining: the impact of consumer values on video sharing and brand equity. *Journal of Research in Interactive Marketing*.

Strauß, A., & Fleischmann, A. (2020). Reconceptualising solidarity in the social factory: Cultural work between economic needs and political desires. *Work, Employment and Society*, 34(1), 109-125.

Teng-Calleja, M., Hechanova, M. R. M., Sabile, P. R., & Villasanta, A. P. V. P. (2020). Building organization and employee resilience in disaster contexts. *International Journal of Workplace Health Management*, 13(4), 393-411.

Thompson, M., Ellis, R., & Wildavsky, A. (2018). *Cultural theory*. Routledge.

Torkelson, E., Holm, K., Bäckström, M., & Schad, E. (2016). Factors contributing to the perpetration of workplace incivility: the importance of organizational aspects and experiencing incivility from others. *Work & Stress*, 30(2), 115-131.

Tricahyadinata, I., Hendryadi, Suryani, Zainurossalamia ZA, S., & Riadi, S. S. (2020). Workplace incivility, work engagement, and turnover intentions: Multi-group analysis. *Cogent Psychology*, 7(1), 1743627.

Trudel, J., & Reio Jr, T. G. (2011). Managing workplace incivility: The role of conflict management styles—antecedent or antidote?. *Human resource development quarterly*, 22(4), 395-423.

Trudel, P. E. (2011). A model of work frustration–aggression. *Journal of organizational behaviour*, 20(6), 915-931.

Turabik, T., & Baskan, G. A. (2020). The relationship between organizational democracy and political behaviours in universities. *Journal of Applied Research in Higher Education*.

Turner, R. L. (2014). Political identity dissimilarity, workplace incivility, and declines in well-being: A prospective investigation. *Stress and health*, 35(3), 256-266.

Umar, M., Ji, X., Kirikkaleli, D., & Alola, A. A. (2021). The imperativeness of environmental quality in the United States transportation sector amidst biomass-fossil energy consumption and growth. *Journal of Cleaner Production*, 285, 124863.

Umar, M., Ji, X., Kirikkaleli, D., & Alola, A. A. (2021). The imperativeness of environmental quality in the United States transportation sector amidst biomass-fossil energy consumption and growth. *Journal of Cleaner Production*, 285, 124863.

VandenBos, G. R., & Bulatao, E. Q. (1996). *Violence on the job: Identifying risks and developing solutions*. American Psychological Association.

Vasconcelos, C. M. (2020). Tit for tat? The spiraling effect of incivility in the workplace. *Academy of management review*, 24(3), 452-471.

Vickers, A. J., & Elkin, E. B. (2006). Decision curve analysis: a novel method for evaluating prediction models. *Medical Decision Making*, 26(6), 565-574.

- Vickers, C. (2006). The long-term athlete development model: Physiological evidence and application. *Journal of sports sciences*, 29(4), 389-402.
- Vigoda, E., & Cohen, A. (2002). Influence tactics and perceptions of organizational politics: A longitudinal study. *Journal of business research*, 55(4), 311-324.
- Vigoda-Gadot, E. (2007). Redrawing the boundaries of OCB? An empirical examination of compulsory extra-role behaviour in the workplace. *Journal of business and psychology*, 21(3), 377-405.
- Vigoda-Gadot, E., & Drory, A. (Eds.). (2006). *Handbook of organizational politics*. Edward Elgar Publishing.
- Vigoda-Gadot, E., & Kapun, D. (2005). Perceptions of politics and perceived performance in public and private organisations: a test of one model across two sectors. *Policy & Politics*, 33(2), 251-276.
- Vijayalakshmi, C., & Sivapragasam, M. K. (2019). Reality monitoring: An experimental phenomenological approach. *Journal of Experimental Psychology: General*, 117(4), 390.
- Vince, J. (2001). Politics and organizational learning. *Journal of Management Studies*, 37(6), 869-886.
- Vonrhein, D. N., Majid, A. H. A., Omar, K., & Aburumman, O. J. (2011). The moderating effect of interpersonal distrust on the relationship between perceived organizational politics and workplace ostracism in higher education institutions. *Heliyon*, 7(6), e07280.

Vredenburg, D., & Shea-VanFossen, R. (2010). Human nature, organizational politics, and human resource development. *Human resource development review*, 9(1), 26-47.

Wang, C., Horby, P. W., Hayden, F. G., & Gao, G. F. (2020). A novel coronavirus outbreak of global health concern. *The lancet*, 395(10223), 470-473.

Wang, C., Xu, D., Zhu, Y., Martín-Martín, R., Lu, C., Fei-Fei, L., & Savarese, S. (2019). Densefusion: 6d object pose estimation by iterative dense fusion. In *Proceedings of the IEEE/CVF conference on computer vision and pattern recognition* (pp. 3343-3352).

Wang, Y., Zhao, L., Wang, J. L., Zhang, W. Z., Zhao, X. Z., & Wu, W. (2010). March, 2010. *Interviewed by Yuhua Wang [in person] Hainan Province.*

Winer, S., Chan, Y., Paltser, G., Truong, D., Tsui, H., Bahrami, J., ... & Dosch, H. M. (2009). Normalization of obesity-associated insulin resistance through immunotherapy. *Nature medicine*, 15(8), 921-929.

Xerri, M. B., & Brunetto, M. (2012). Impact of organizational politics on employee work outcomes in higher education institutions of Pakistan: Moderating role of social capital. *South Asian Journal of Business Studies*.

Yılmaz, E., Özer, G., & Günlük, M. (2014). Do organizational politics and organizational commitment affect budgetary slack creation in public organizations?. *Procedia-Social and Behavioural Sciences*, 150, 241-250.

Yılmaz, E., Özer, G., & Günlük, M. (2014). Do organizational politics and organizational commitment affect budgetary slack creation in public organizations?. *Procedia-Social and Behavioural Sciences*, 150, 241-250.

- Yilmaz, T. R. (2014). Initial genome sequencing and analysis of multiple myeloma. *Nature*, *471*(7339), 467-472.
- Young, N., & Javalgi, F. (2010). Magnesium alloys as implant materials—Principles of property design for Mg–RE alloys. *Acta biomaterialia*, *6*(5), 1714-1725.
- Zaleznik, A. (1971). Power and politics in organizational life. *McKinsey Quarterly*, *7* (4), 52-69.
- Zeleny, M. (2012). *Linear multiobjective programming* (Vol. 95). Springer Science & Business Media.
- Zhang, H., Zheng, Z., & Darko, S. S. (2018). Psychological reactance and the attractiveness of unobtainable objects: Sex differences in children's responses to an elimination of freedom. *Sex Roles*, *7*(9), 937-949.
- Zhao, L., Zhang, Y., Huang, L. B., Liu, X. Z., Zhang, Q. H., He, C., ... & Wan, L. J. (2019). Cascade anchoring strategy for general mass production of high-loading single-atomic metal-nitrogen catalysts. *Nature communications*, *10*(1), 1-11.
- Zhou, J., Bi, G., Liu, H., Fang, Y., & Hua, Z. (2018). Understanding employee competence, operational IS alignment, and organizational agility—An ambidexterity perspective. *Information & Management*, *55*(6), 695-708.
- Zhou, Z., Liu, X., Sun, K., Lin, C., Ma, J., He, M., & Ouyang, W. (2019). Persulfate-based advanced oxidation processes (AOPs) for organic-contaminated soil remediation: A review. *Chemical Engineering Journal*, *372*, 836-851.

Zikmund, W. G., Babin, B. J., Carr, J. C., & Griffin, M. (2003). Research methods. *Health economics research method*, 2.



APPENDICES
APPENDIX A: INTRODUCTORY LETTER
UNIVERSITY OF CAPE COAST
SCHOOL OF BUSINESS
DEPARTMENT OF MANAGEMENT

Telephone: 03321 32440/32444 Ext. 219/220 UNIVERSITY POST OFFICE

Direct: 03321 37870 CAPE COAST, GHANA

Telegrams: University, Cape C

Telex: 2552, UCC, GH.



Dear Sir/Madam,

INTRODUCTORY LETTER FOR DORIS ADUSU

The bearer of this letter, Doris ADUSU is an MCOM (Management) student of the Department of Management, School of Business. She is writing his dissertation on the topic: “ORGANISATIONAL POLITICS AND ITS IMPACT ON WORKPLACE INCIVILITY OF SENIOR STAFF AT THE UNIVERSITY OF CAPE COAST: MODERATING ROLE OF EMPLOYEE RESILIENCE”.

We would be grateful if you could assist her with the filling of the questionnaires and any other information that she may need to complete her work.

We appreciate your co-operation.

Yours faithfully,

Signed

N.O.O. (HEAD)

APPENDIX B: QUESTIONNAIRE**UNIVERSITY OF CAPE COAST****SCHOOL OF BUSINESS****DEPARTMENT OF MANAGEMENT**

Dear Respondent,

I am a student of University of Cape Coast, offering Master of Commerce (Management) programme at the School of Business, Department of Management.

This questionnaire is designed to ascertain information for my research work on the topic: **“ORGANISATIONAL POLITICS AND ITS IMPACT ON WORKPLACE INCIVILITY OF SENIOR STAFF AT THE UNIVERSITY OF CAPE COAST: MODERATING ROLE OF EMPLOYEE RESILIENCE”**. This research is in partial fulfilment of the requirement for the award of a Master of Commerce Degree in Management at the University of Cape Coast.

All the answers you provide will be treated with the utmost confidentiality and for academic purpose only. Please feel free to answer the questions as candid as possible.

Thank you

Doris ADUSU

SECTION A

SOCIO-DEMOGRAPHIC DATA OF RESPONDENTS

To answer a question, either tick [] or write short notes on the space provided

where necessary.

1. Gender:

- a. Male []
- b. Female []

2. Age:

- a. Below 30 years []
- b. 31-40 years []
- c. 41-50 years []
- d. 51 years and above []

3. Level of Education:

- a. Diploma []
- b. 1st Degree []
- c. 2nd Degree []
- d. Professional []

4. Marital Status

- a. Married []
- b. Single []
- c. Divorced []
- d. Other []

5. Employees' Years of Work in the Organisation

- a. 1-5 years []
- b. 6-10 years []
- c. 11-15years []
- d. 16 years and above []

SECTION B

QUESTIONNAIRES ON ORGANISATIONAL POLICTICS

In a 7-point Likert scale, where 1 – Least level of Agreement and 7 – Highest level of Agreement, rate the following statements on the basis of how organisational politics take form at the University of Cape Coast within your capacity and knowledge as a staff.

ORGANISATIONAL POLITICS

NO.	STATEMENT	1	2	3	4	5	6	7
Mutual Relationship								
1	People are ingratiated with other people to obtain the outcomes they desire.	1	2	3	4	5	6	7
2	People in this organisation, by breaking down others, seek to build themselves up.	1	2	3	4	5	6	7

3	People use their relationships improperly to circumvent the organisational processes	1	2	3	4	5	6	7
4	Individuals build partnerships to get personal benefits.	1	2	3	4	5	6	7
Employee Communication								
5	Employees are inspired to express forthrightly even though critical of well-established ideas.	1	2	3	4	5	6	7
6	In this department there has always been an important group that no-one ever crosses	1	2	3	4	5	6	7
7	Gossip is shaping the way people view what is going on in this company	1	2	3	4	5	6	7
8	Gossip is the primary form of sharing the information.	1	2	3	4	5	6	7
Self-Reputation								
9	In order to make themselves look great, individuals stab each other in the back.	1	2	3	4	5	6	7
10	People are trying to make themselves look good by making others look incompetent.	1	2	3	4	5	6	7

11	People are damaging the reputation of others behind the backs.	1	2	3	4	5	6	7
Rewards and Compensations								
12	Existing regulations are meaningless when it comes to making pay increase and promotion decisions	1	2	3	4	5	6	7
13	More than merit, favoritism determines who goes ahead here.	1	2	3	4	5	6	7
14	Rewards only apply to those who work hard inside this organisation.	1	2	3	4	5	6	7
15	What you know and how much you like holds a lot of weight inside this organisation.	1	2	3	4	5	6	7

NOTE: The items in this instrument were adopted from Chahar and Hatwal (2021, July)

In a 7-point Likert scale, where 1 – Least level of Agreement and 7 – Highest level of Agreement, rate the following statements on the basis of employee resilience in the organisation.

SECTION C: EMPLOYEE RESILIENCE

NO.	STATEMENT	1	2	3	4	5	6	7
-----	-----------	---	---	---	---	---	---	---

1	An individual trusts in his or her ability to overcome challenges and obstacles	1	2	3	4	5	6	7
2	A person believes he can achieve positive life outcomes and how he explains the setbacks he encounters	1	2	3	4	5	6	7
3	People believe they should find solutions to the problems they face	1	2	3	4	5	6	7
4	Individuals appreciate interactions which challenge them and see stretching conditions as opportunities for learning and growth	1	2	3	4	5	6	7
5	A person should keep his/her emotions calm and in control	1	2	3	4	5	6	7
6	A person willingly asks others for help and support when dealing with difficult situations	1	2	3	4	5	6	7

NOTE: The items in this instrument were adopted from Chahar and Hatwal (2021, July)

In a 7-point Likert scale, where 1 – Least level of Agreement and 7 – Highest level of Agreement, rate the following statements on the basis of Workplace incivility in the organisation.

SECTION D: WORKPLACE INCIVILITY

NO.	STATEMENT	1	2	3	4	5	6	7
1	Lack of mutual respect and trust among the employee	1	2	3	4	5	6	7
2	Continuous productive hour losses due to unusual discussion	1	2	3	4	5	6	7
3	Inappropriate and derogatory remarks about other people characteristics	1	2	3	4	5	6	7
4	Lack of acknowledgement and respect senior.	1	2	3	4	5	6	7
5	Presence of avoidance attitude	1	2	3	4	5	6	7
6	Loss of enjoyment in the organisation	1	2	3	4	5	6	7
7	Prevalence of professional exclusion	1	2	3	4	5	6	7
8	Humiliation and intimidation behaviour can be experienced at the work place	1	2	3	4	5	6	7

NOTE: The items in this instrument were adopted from Chahar and Hatwal (2021, July)