

Introduction to HVDC Technology for Reliable Electrical Power Systems

Johan Setréus, *Graduate Student Member, IEEE*, and Lina Bertling, *Member, IEEE*,

Abstract—The transmission system is becoming ever more complex. Furthermore, demand for reliable supply of electricity is growing, increasing the need for a higher level of system reliability. A solution might be to incorporate controllable power components within the system. One such component is the HVDC link. However, in the domain of reliability models for HVDC and the component's impact on the overall transmission system reliability, there is still much work to be done. This is an important issue in future grid planning, especially with an increasing penetration of HVDC links within synchronous transmission systems acting as "firewalls". These links may prevent disturbances propagating in the system, which is a common cause of blackouts.

This paper provides a broad introduction to the HVDC technology and a literature review of reliability assessments published within this area. It gives a background to and motivation for the technology. Published reliability assessments of the HVDC technology have been reviewed and categorized. One conclusion is that a large number of models and methods for the reliability evaluation of the HVDC system itself have been published, but very few on its impact on the composite system reliability. One future challenge to be solved is how the "firewall" properties of the HVDC can be quantified in a reliability assessment.

Index Terms—Power transmission reliability, Reliability models, HVDC, transmission system

I. INTRODUCTION

POWER transmission utilized with DC is not a new idea. The first commercially generated electricity by Thomas Alva Edison in the 1880s was DC at low voltage levels [1]. The first electricity transmission system was also DC, but because of the low voltage levels the electric energy had to be generated close to its consumers to avoid too large losses. The AC system by Nikola Tesla made it possible to easily transform the voltage to higher voltage levels, suitable for transmission of electric power over long distances. The generation of power no longer needed to be close to its customers; instead it could be placed where the source of energy was located. For this reason the winner in the "war of currents" in the late 1880s was the AC technology and it has been the dominating technology for power transmission ever since. History may have looked different if there had been a technology earlier that was able to step up the DC voltage to a higher level, as the transformer does with AC. In 1901 such a component made it possible when Hewitt's mercury-vapour rectifier was presented. This high voltage valve made it possible, at least in theory, to

transmit DC power at high voltage levels and thereby long distances. The high voltage direct current (HVDC) technology was born. The development of the mercury arc valves in the 1930s improved the technology and in 1945 a commercial HVDC system in Berlin was commissioned. This system was never put into operation [2]. In 1954 the first commercial HVDC transmission was put into operation with a 96 km sea cable, 20 MW, between the Sweden mainland and the island of Gotland. Many mercury-arc-based transmission systems were to follow all around the world.

The development of power electronics and semiconductors in the late 1960s led to the thyristor based valve technology, first tested in the Gotland transmission in 1967, and later introduced on a larger scale in Canada 1972 with a rating of 320 MW. Today the thyristor based line commutated current source converter (CSC) technology is used in the majority of the HVDC transmissions in the world and one of the largest is the Three Gorges - Shanghai link with a rating of 3000 MW and ± 500 kV [3], [4]. The CSC-HVDC technology is also referred to as HVDC Classic (ABB), or only HVDC.

During the late 1990s the development of semiconductors for power electronics, such as IGBTs (Insulated-gate bipolar transistor) and GTOs (Gate turn-off thyristor), had reached the point where their ratings made it possible to be used for voltage source converters (VSC). The first commercial VSC based HVDC transmission was first commissioned in 1999 on the island of Gotland with an underground cable of 50 MW. An HVDC system with VSC is also referred to as VSC-HVDC, HVDC Light (ABB) or HVDC PLUS (Siemens). Recent years of ever increasing development of the semiconductors have improved the VSC technology and the largest commissioned VSC-HVDC installation is now the Estlink, connecting Estonia to Finland with a rating of 350 MW and ± 150 kV DC voltage [5]. Development of higher power and voltage ratings with this technology (up to 1,100 MW and ± 300 kV) is on going [6].

The objectives of this paper are to give an introduction to the HVDC technology and to present what has been published on reliability assessments for HVDC systems. The methodology adopted in the literature review is to categorize the different objectives and models from a number of papers in IEEE Explorer. The objective of this review and for future work is to find solutions to make quantitative reliability assessments of the transmission system with an increased penetration of HVDC. Not much has been published within this research area, and this paper is intended to serve as a basis for further work on system solutions.

This work was supported by the Swedish Centre of Excellence in Electric Power Engineering. J. Setréus and L. Bertling is with the School of Electrical Engineering, Royal Institute of Technology, KTH, Stockholm, Sweden.
E-mail: johan.setreus@ee.kth.se and lina.bertling@ee.kth.se

II. RELIABILITY EVALUATION OF TRANSMISSION SYSTEMS

A modern power system is a very complex technical structure. It consists of a large number of interconnected subsystems and components each of which interact with and influence the overall system reliability. One definition of reliability is the ability of a component or system to perform required functions under stated conditions for a stated period of time [IEEE Std 493-2007]. Reliability assessments of the electrical system are performed in order to determine where and when new investments, maintenance planning and operation are going to be made. This assessment can be performed either by deterministic or probabilistic methods, each with its own advantages. The key advantages for the probabilistic technology are its ability to quantify the stochastic nature of the system and to include all combinations of component outages in the model.

Power system reliability is often divided by the two functional aspects of system adequacy and security. Adequacy is the ability of the power system to supply the aggregate electric power and energy requirements of the customer at all times, taking into account scheduled and unscheduled outages of system components. Security is the ability of the power system to withstand sudden disturbances such as electric short circuits or non-anticipated loss of system components [7].

A reliability model that includes the whole complexity of the entire electrical power system would be impossible to implement. The analysis would be far too complex and the results would be very difficult to interpret. Instead it is preferable to separate the system into three hierarchical levels: generation (HL1), generation and transmission (HL2) and distribution (HL3). Each level can then be modelled and evaluated individually [7]. A study of HL2 is also referred to as a composite system reliability assessment and this can include both adequacy and security analysis. Reliability assessments of HVDC systems can be modelled and evaluated separately and then included into HL2 to evaluate the effect of the overall system reliability.

In reliability assessments of systems, such as the HVDC, it is, in our opinion, of the greatest importance to know the technical system in order to model it. For this reason the next section describes the HVDC system in detail.

III. HVDC SYSTEM OVERVIEW

The HVDC technology is used in transmission systems to transmit electric bulk power over long distances by cable or overhead lines. It is also used to interconnect asynchronous AC systems having the same or different frequency. Figure 1 shows a simplified schematic picture of an HVDC system, with the basic principle of transferring electric energy from one AC system or node to another, in any direction. The system consists of three blocks: the two converter stations and the DC line. Within each station block there are several components involved in the conversion of AC to DC and vice versa.

A. Terminology

The following terms are found necessary to define for the following sections of the paper. Figure 1 and Figure 4 can be

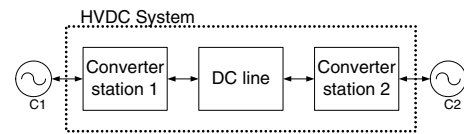

Fig. 1. Schematic of the overall system perspective of a general HVDC system, transferring electric energy from one AC system or node to the other, in any direction.

used as a guide.

- **The HVDC system** contains the converter stations and the transmission lines or cables.
- **The HVDC converter station or HVDC station** includes the AC switchyard, the converter transformer system, the converters and the auxiliary subsystems in the station.
- **The valves** are located in the converters and consist of a number of thyristors or transistors, depending on HVDC technology, that are connected in series.
- **The converter transformer system (CTS)** is the arrangement of converter transformers that are connected to the valves [8].
- **CSC-HVDC** is the technology where line commutated current source converter (CSC) is used. Company trademarks are HVDC Classic (ABB) or simply HVDC.
- **VSC-HVDC** uses the voltage source converters (VSC) as its core component to convert AC to DC and vice versa. The company trademarks are HVDC PLUS (Siemens), HVDC Light (ABB) or VSC-HVDC.

B. Motivations for using HVDC

The reasons for choosing HVDC are generally economic and not technical. Power system stability improvements and environmental circumstances may, however, also be reasons for choosing this technology. Below, a number of HVDC applications are listed in order to illustrate the key characteristics and HVDC's niche on the power market.

1) *Long distance bulk power transmissions:* As the world's energy resources are normally decentralized from the ever increasing energy consumption, long HVDC transmissions are a particularly interesting area for the future. A key characteristic of HVDC transmissions is higher power transfers in fewer lines than an equivalent AC solution [9]. Furthermore, one major constraint when designing traditional AC transmission lines over long distances is the significant inductance such a line will have. The effects of the inductance have to be compensated along the AC line and this adds costs for long distances. For DC the frequency is zero; hence the inductance is irrelevant. For this reason an overhead DC line with its towers can be designed to be less costly per km than an equivalent AC solution, if both the investment and a capitalization of the total energy losses are considered. However, the HVDC converter stations at both ends are more costly than equivalent AC terminals and thereby an economical break-even distance arises, as illustrated in Figure 2.

Two examples of commissioned long distance bulk power HVDC transmission is the four links from Itaipu in Brazil

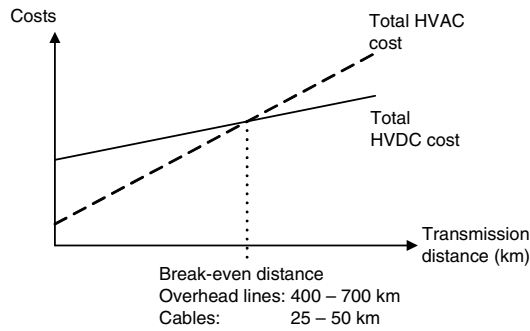

Fig. 2. Illustration of how the total cost for an AC and HVDC solution depends on the transmission distance [10]. The break-even distance, where the HVDC solution becomes more economical than an equivalent AC, greatly depends on the land conditions and project specifications.

(with a total rating of 10258 MW) [3] and the Three Gorges in China ($3 \times 3000 + 1200$ MW) [3]. Both of these installations connect large hydropower resources to populated areas.

2) *Long cable transmissions:* The charging current in cables being fed with high voltage AC (HVAC) makes transmissions over long distances impractical. In order to keep the voltage levels and losses within reasonable limits, the HVAC solution requires reactive power compensation equipment along the cable. Such equipment adds cost to the link, and is in some cases not possible to implement. One example is undersea transmissions, where such a solution is highly impractical. If the cable is fed instead with HVDC, the large capacitance is irrelevant since the charging current is frequency dependent [11].

One example installation is the Swepol Link interconnecting Sweden to Poland with a 254 km undersea cable at a rating of 600 MW [3], [12].

3) *Asynchronous interconnection:* The HVDC technology can connect two asynchronous power systems with the same or different frequency. The interconnection is often beneficial for both of the systems and acts as a buffer between them. In case of cascading failures in one of the systems, the interconnection can serve as a "firewall" between the systems, preventing the propagation of disturbances from continuing into the connected system [9]. The HVDC system can also be designed to help the AC system in damping power oscillation between the systems after disturbances.

If the HVDC system is built only for its ability to perform asynchronous interconnection, with no line, the setup is referred to as a back-to-back configuration. One example of this application is the four main asynchronous AC systems in North America, interconnected to each other with twelve back-to-back links [10].

4) *Stabilization in power systems:* HVDC links can be used within synchronous AC systems to improve the control of power flow from one part of the system to another and thereby prevent large cascading failures or even blackouts in the grid. The stability can be improved, since the link provides a damping torque [13]. The introduction of this sort of application in the existing AC system requires an extensive knowledge of the electrical system in order to design proper control algorithms for the HVDC link. However, this area of

application is still very much unknown and research is going on.

One example of this type of application in a larger synchronous AC system is the Chandrapur-Padghe link (1500 MW) in India [3]. This link has been built to stabilize the system and to increase the power flow capabilities.

C. Environmental aspects

One of the reasons for choosing HVDC is the low impact on the surrounding environment. The environmental aspects of an HVDC transmission line can be divided into four categories [13]:

1) *Visual impact and space requirements:* An HVDC transmission with an overhead line requires less space per MW than the traditional AC solution and thereby reduces the visual impact of the towers. If a cable is used, the only visual impact is the converter stations. However, the size of these stations in comparison with a traditional AC switchyard may have a larger visual impact that has to be dealt with.

2) *Electric and magnetic fields:* The magnetic field produced by a DC line is stationary while in the AC case it is alternating, which can cause inducing body currents. This results in fewer restrictions for the magnetic field in the HVDC line [14]. The electric field is less severe in the DC line compared to the AC line since there is no steady-state displacement current in the DC case [13]. However, an undersea HVDC line can cause disturbances to magnetic compass systems on vessels crossing the cable.

3) *Radio interference:* The harmonics created in the switching process by the converters cause disturbances in the kHz and MHz region. An appropriate shielding of the valves minimizing this problem and makes the radio interference comparable with AC solutions [13], [15]. Radio interference is on the other hand normally a minor problem in the transmission system.

4) *Audible noise:* The converter stations cause audible noise levels that are normally higher than comparable AC solutions [13]. However, if necessary this issue can be dealt with by the use of low-noise components or enclosure of specific components such as the transformers.

D. Comparison of CSC-HVDC and VSC-HVDC

The applications mentioned earlier are mainly implemented with CSC-HVDC. For VSC-HVDC, which has a relatively low power rating and is still quite new, its properties make it suitable for other areas of applications such as small isolated remote loads, in-feed to city centres, remote small-scale generation and off shore generation [5]. The following list points out the differences of an VSC-HVDC and an CSC-HVDC system [5], [10], [13]:

- The active and reactive power can be controlled independently of each other in an VSC-HVDC system. Hence, no reactive compensation equipment is needed at the converter stations.
- It is possible to eliminate the converter transformers in VSC-HVDC systems.

- Due to the low short-circuit level of VSC-HVDC, it can be used to start up weak AC networks that lack generation after major blackouts, for example.
- VSC-HVDC does not have a minimum power level that can be transferred; hence the active power can be controlled between 0 and 100 %.
- The high switching frequency for VSC-HVDC results in smaller AC filters for harmonics elimination than CSC-HVDC.

During the past decade the energy loss in the converter stations have been reduced with the development of valve and station technology [10]. For CSC-HVDC the losses are around 0.6% of the rated HVDC transmission capacity per converter station [6]. For VSC-HVDC this value is around 1.6% [6].

E. HVDC Configurations

Depending on the application and location, a number of different HVDC station configurations can be identified. In this paper these are presented for CSC-HVDC, with CSC converter symbols, but similar configuration setups exist for VSC-HVDC [5].

1) *Back-to-back configuration*: Figure 3(a) shows a block diagram of the back-to-back configuration with a 12-pulse configuration. In this configuration the HVDC stations are located at the same site, with no transmission line between them, interconnecting two AC systems. The frequency can be the same or different and the AC system asynchronous.

2) *Monopolar configuration*: A monopolar configuration with a 12-pulse configuration is shown in Figure 3(b). The configuration is mainly used in undersea transmissions [5]. This consists of two HVDC stations connected with a single conductor line having a positive or negative polarity. The return current is returned either via the ground or a relatively small metallic conductor.

3) *Bipolar configuration*: The bipolar configuration can be seen as two monopolar configurations in parallel, with a positive and negative pole. Figure 3(c) shows a block diagram of a 12-pulse bipolar configuration. The bipolar is commonly used in bulk power transmission lines with overhead lines [5]. If an outage occurs in one pole, it is still possible to run the HVDC system in a derated state with the remaining pole and with an earth return current. If the conductor at the failed pole is still intact, this can be used as a metallic current return in order to minimize the losses during the failure.

F. Main components in a typical HVDC station

The component setup in the two converter stations at each side of the link is normally identical. Small differences, related to the properties of the connected AC system, can nevertheless be the case in the rating of the shunt capacitor banks. Figure 4 shows a typical block diagram, including the main components, of a monopolar HVDC converter station with a 12-pulse configuration.

1) *AC switchyard*: The first block summarizes the components in the AC switchyard which includes AC filters, circuit breakers, disconnectors and busbars. For CSC-HVDC shunt capacitor banks for reactive power compensation are installed.

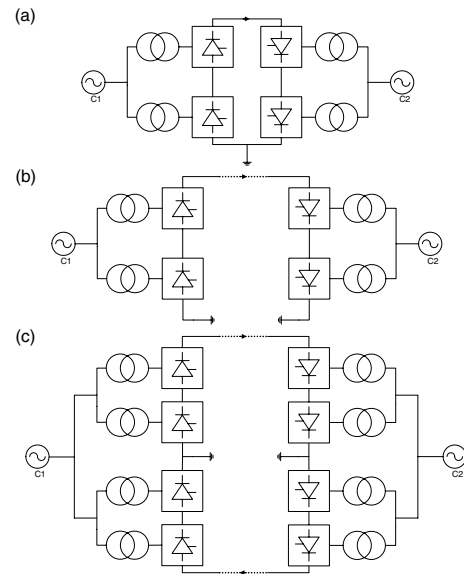

Fig. 3. Three basic HVDC configurations with different converter arrangements: (a) Back-to-back configuration; (b) Monopolar configuration and (c) Bipolar configuration.

The AC filters are installed to limit the harmonics caused by the converters. If several capacitor banks and AC filters are installed and one or more suffer an outage, the link may still be possible to operate in a derated state.

2) *Converter transformers*: The second block, the converter transformer, is normally implemented with either one three-phase or three single-phase transformers, but other configurations are possible [8]. This converter arrangement is also referred to as the Converter Transformer System (CTS). The choice of arrangement is highly dependent on the transportation requirements [16]. The name converter transformer arises from the slightly different design and requirements of these types of transformer compared to a conventional transformer. It serves as a galvanic isolator between the AC and the DC side and transforms the voltage to an appropriate and optimum level for the converter valves.

3) *HVDC Converter*: This consists of a number of converter valves, each consisting of a number of series-connected thyristors (CSC-HVDC) or IGBT components (VSC-HVDC). Since the criterion is normally that a single failure of these should not cause an outage of the valve, and thereby the station, they are typically redundant with two or three components. The components that fail can then be replaced at the next maintenance occasion [17].

4) *Transmission medium and DC filters*: The transmission medium is either overhead line, cable or a combination of these. The cables are normally used for overseas transmissions and can be either oil-filled or solid [16].

The DC filters are designed to reduce the harmonics from the HVDC converters, in order to avoid disturbances in telecommunication systems. Usually no filters are needed in pure cable transmissions [16].

In case of a cable failure, some HVDC systems have equipment installed to determine the distance to the failure in order to reduce the restoration time.

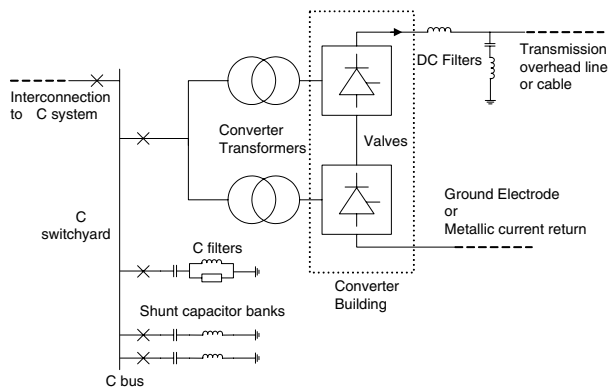

Fig. 4. Single line diagram illustrating the main components in a monopolar HVDC converter station.

5) *Auxiliary systems*: Examples of these systems are the converter valve cooling, transformer cooling, control systems and the internal station power supply with the battery backup. The valve cooling system is especially crucial since an outage here may result in serious damage to the valves, and this system is therefore normally redundant.

IV. REVIEW OF STANDARDS, WORKING GROUPS AND RELIABILITY RECORDINGS OF HVDC INSTALLATIONS

A. IEEE guide for the evaluation of reliability

The IEEE Std 1240-2000 [18] is a guide for the evaluation of the reliability of HVDC converter stations. The purpose of this guide is to promote the basic concepts of reliability, availability and maintainability (RAM) in all phases of the HVDC station's life cycle. The intention of introducing these concepts of RAM in HVDC projects is to provide help in: (i) improving RAM for stations in service, (ii) calculating and comparing RAM for different HVDC designs, (iii) reducing costs, (iv) reducing spare parts and (v) improving HVDC converter specifications [18]. Theory and definitions related to basic HVDC reliability are defined in the report.

B. IEEE HVDC projects listing

A list of the commissioned HVDC projects in the world is provided by a working group in the IEEE Transmission and Distribution committee [3]. The list includes commercial HVDC stations in use, retired from serviced, planned and under construction, with their rating, line or cable length, location and year commissioned. This listing could be very valuable in the work of collecting reliability statistics for HVDC stations in the future. In Table I a short summary of this list has been made and it shows that a large number of projects are planned in the future. The project listing in [3] also shows that the absolute majority of the installations are CSC-HVDC. VSC-HVDC accounts for five of the commissioned stations. Of the projects that are planned or under construction only one out of 57 is VSC-HVDC (November 2006).

C. Availability recordings of HVDC stations in world

The CIGRÉ working group B4.04 collects reliability recordings from a number of HVDC systems in the world. The

TABLE I
STATUS OF THE COMMISSIONED AND PLANNED COMMERCIAL HVDC INSTALLATIONS IN THE WORLD [3]

Commissioned	Retired	Under construction	Planned
114	9	6	51

objective of sharing data is that it could be useful in the planning, construction and operation of new and existing projects [18]. The first data were collected in 1968, including four installations. In 2001, for example, 32 HVDC systems reported their reliability data to the group. The data include general information regarding the station such as a system description, main circuit data and a simplified single line diagram. This information is presented and summarized in a compendium available from the working group. Operational performance data is collected annually from each installation and summarized in a report every second year with the title "A Survey of the Reliability of HVDC Systems Throughout the World" [19]. Guidelines which specify how the reliability recording procedure of the members HVDC stations should be performed is included in the CIGRÉ document "Protocol for Reporting the Operational Performance of HVDC Transmission Systems" [18] [20]. This standardized procedure makes it possible to compare historically accumulated data from several systems in order to judge the performance of a specific system. The data includes a number of reliability measures for the HVDC system such as the energy availability and energy utilization. It also includes forced outage data for six different component categories within the system, with the number of failures and equivalent outage time in hours.

V. LITERATURE REVIEW OF RELIABILITY ASSESSMENTS OF HVDC

A. Introduction

Several papers have been published in the area of assessing the reliability of the HVDC System as a single system. Three of the first papers in this area are by C.R. Heising, R. Ringlee [21] and by R. Billinton, V. Prasad [22], [23], published in 1970 and 1971. In these papers the HVDC system is modelled in a reliability block diagram with a number of key components for the HVDC, similar to the component categorization previously presented in Figure 4. Each component, or block, is then modelled separately to include component reliability data and redundancy. In [22], [23] Markov models have been used in order to include the transmission capacity states of the system and the use of spare components. The component models [23], or the results from them [21], are then combined and evaluated analytically. The results are the expected forced outages per year and downtime per year for the total HVDC system.

Later published papers within this area are more or less based on the same methodology as these first three. Typically, an HVDC single line diagram is transferred to a reliability block diagram with a number of key components. An example of such a diagram, typical of these papers, is shown in Figure 5. The contributions in more recently published papers (e.g. [24], [25]) are, however, larger case systems and more

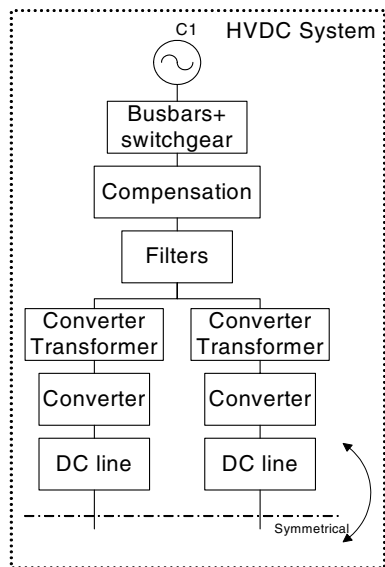

Fig. 5. An example of a reliability model for an HVDC system.

advanced component models. In the following sections, the studied papers has been categorized. Most of them focus on the reliability evaluation of the HVDC system itself. Few papers evaluate the overall system perspective of introducing HVDC in a composite AC system, but these have on the other hand been reviewed in more detail in this paper.

B. Review of typical objectives

Table II shows a categorization of the typical objectives in papers including reliability assessments of HVDC.

C. Models of the bipolar HVDC

In [26]–[29] the bipolar HVDC system configuration, as shown in Figure 3c, has been modelled. The reliability models in these four papers are similar to each other but the objectives in the papers differ.

In [27] by S. Kuruganty the impact on the HVDC system reliability is studied when spare components are included and the rating of the valves is increased. The spare part alternatives include the converter transformers and reactive power compensation equipment. A cost benefit analysis is performed to determine if the reliability improvements are balanced against the investments.

The AC filter and compensation banks are also modelled in [28]. Different capacity levels in these banks result in a transmission capacity model for the HVDC system.

Paper [29] by G. Desrochers et al. gives a detailed overview of the reliability theory, and one algorithm suitable for reliability assessment of HVDC.

D. Models of general HVDC systems

More general papers for the reliability assessment of HVDC system are presented in [24], [31]–[33]. These models are not restricted to the bipolar HVDC arrangement. An arbitrary value of N different poles (multipolar) can be included and

TABLE II
SUMMARY OF TYPICAL OBJECTIVES IN RELIABILITY ASSESSMENTS OF HVDC SYSTEMS.

Objective of study	Found papers
Evaluate the expected availability of an HVDC system or station	[24], [26]–[33]
Evaluate reliability impact of the inclusion of an HVDC system in a composite transmission system	[25], [34], [35]
Reliability evaluation of different spare component configurations for HVDC	[8], [27]
Evaluate the well-being of the HVDC system by quantifying a distinct number of deterministic operating states	[24], [31]–[33]

evaluated by these models. An example of multipolar arrangements is when two or more bipolar configurations are used in long distance bulk power transmissions. In [24], [31], [32] the operating states Healthy, Marginal and At Risk are introduced to indicate the well-being of the link.

In [30] a reliability model for assessments of hybrid multi-terminal HVDC systems is presented. In this type of configuration there are a number of VSC inverter stations at the DC side of the CSC-HVDC system.

E. Reliability assessment of HVDC systems in composite power systems

In the literature review only three papers covering the overall system perspective of HVDC systems incorporated in AC systems were found.

1) *Paper 1 - HVDC incorporated in IEEE-RTS*: The incorporation of an HVDC link in a composite system is presented in [34] by R. Billinton and D.S. Ahluwalia. The IEEE Reliability Test System (IEEE-RTS) [36], developed as a reference network for system reliability evaluations, has been used in the study. This transmission system consists of 24 buses, 33 transmission lines and 32 generating units. Each component and generating unit has a given reliability outage data. Compared to other reliability test systems that have been published, this is one of the most documented.

The modelled HVDC link, transferring energy from a remote generation source, replaces a generation unit in bus 22 in the IEEE-RTS. The reliability model for the HVDC system, representing the EEL river bipolar system (320 MW), is described and modelled in [37]. This HVDC model has first been evaluated separately and the results from this are then included in the composite reliability evaluation of the entire system. The sub-results from the HVDC model consist of a table with the probability for each capacity state of the link in MW, the average failure frequency per year and the mean outage duration in hours for the link. Composite reliability analysis is performed on both the original IEEE-RTS and a modified version with the modelled HVDC link included. A second case, with a double capacity in all HVDC components (640 MW), is also assessed. For the evaluation of the system reliability indices, the computer program COMREL has been

used. This program uses the enumeration approach with a standard network flow method.

The result from the modified systems shows a reduction in the system reliability. The result is expected as the connected HVDC system, connecting a remote energy resource, replaces a local generation unit with fewer components, lower failure rate and shorter outage time.

2) *Paper 2 - HVDC incorporated in IEEE-RTS, ver. 2:* In [25] by R. Billinton and A. Sankarakrishnan a second reliability assessment of the incorporation of an HVDC link in IEEE-RTS has been made. This paper is a development of the first published paper in [34] and it clearly shows how composite HVDC evaluations can be performed. In addition to the earlier inclusion of the remotely connected HVDC link in IEEE-RTS, a second case is also investigated. In this case a double circuit AC line is replaced with an equivalent rated bipolar HVDC line. The HVDC model is again based on the EEL river link. The reliability computer program MECORE, using the Monte Carlo simulation technique, has been used instead of COMREL in the evaluation of the reliability indices. Moreover, a DC load flow algorithm is used to evaluate the system contingencies, instead of the network flow method.

The result shows that the replacement of the double circuit AC transmission line in IEEE-RTS does not have a significant effect on the overall system reliability. Only a small reduction in reliability is noted. The authors conclude that the impact could be different for other systems having different size.

3) *Paper 3 - HVDC in parallel with an AC line solution:* In [35] M. Fotuhi-Firuzabad, R. Billinton and S.O Faried describe a technique to perform AC/DC system reliability analysis in a composite power system with both an HVDC system and an AC line with a thyristor controlled series capacitor (TCSC). The TCSC is a device that can be connected in series with an AC line in order to adjust the transmission infeed impedance and thereby increase the transmission system capacity. The TCSC is within the concepts of the more well known technology area of Flexible AC Transmission Systems (FACTS).

The studied transmission system model consists of two small areas, A and B, both having load points and generation units. In one of two cases studied in the paper, a bipolar HVDC and a line with TCSC are connected in parallel between the two areas. A reliability block diagram model for both the HVDC link and the TCSC is presented and evaluated. The results from each model are the probability for the different capacity performance levels in percent. When the two models are combined, the probabilities for each performance level are given in percent of the maximum transfer capacity of the parallel system. The reliability system indices are then evaluated with a contingency enumeration technique for the entire system. The paper shows how combined reliability analysis with HVDC and TCSC can be performed.

F. Discussion of HVDC systems in composite power systems

In papers 1 and 2 above, the relatively simple network flow model and DC (decoupled) load flow model have been used

in the analysis of IEEE-RTS with an HVDC. These methods cannot include the correct behaviour of such factors as the compensation equipment and low voltage levels at each side of the HVDC system. In paper 2 the authors point out that the more accurate AC load flow method would significantly slow down the Monte Carlo simulation. It would, however, be very interesting to study the impact on the result if an AC load flow technique were used instead in this assessment. This would probably be possible with today's computer resources.

If a comparison between the AC and HVDC solution is performed, where, for example, a double AC line is replaced by a bipolar HVDC, the question is how these alternatives are designed and evaluated for a fair reliability assessment. One alternative is to compare the reliability impact from two equivalent power ratings of AC and HVDC, another to compare the solutions with the same total cost.

In the literature review no papers were found that include and quantify the dynamic properties of the HVDC system in the reliability models. In the same way as an ordinary AC circuit breaker may stop a short circuit, the HVDC has the ability to damp large power oscillations in the power system, as described in Section III-B4. The HVDC can in this way be designed to act as a "firewall" and prevent large disturbances propagating in the system.

VI. CONCLUSIONS

This paper has given an introduction to the HVDC technology, with its motivations and applications. The main configurations and components in a typical HVDC system have been shown.

A literature review of published reliability assessments of HVDC systems has been presented. One conclusion from this review is that a large number of reliability assessments of the HVDC system itself have been published, but very few in the area of its impact on the composite power system reliability. The reliability analysis for the evaluation of the composite system reliability with HVDC does not include the AC load flow method that may give different results than less accurate techniques used in the reviewed papers. Today the computer resources are more sufficient for the inclusion of such methods in the reliability calculations.

In the literature review no papers were found that include and quantify the dynamic "firewall" properties of the HVDC system in the reliability models. If these properties could be modelled, this would mean a significant improvement in the HVDC models and thereby the ability to evaluate the impact on system reliability of an increasing number of HVDC links incorporated in the transmission system.

REFERENCES

- [1] R. Moran, *Executioner's current Thomas Edison, George Westinghouse, and the invention of the electric chair, Chapter: The Battle of the Currents.* New York : Vintage Books, 2003, ISBN 037572446X.
- [2] SIEMENS, "High voltage direct current transmission - proven technology for power exchange," Mars 2007, brochure from SIEMENS, Source <http://www.siemens.com>.
- [3] DC and Flexible AC Transmission Subcommittee of the IEEE Transmission and Distribution Committee by the Working Group on HVDC and FACTS Bibliography and Records, "HVDC projects listing," *IEEE*, November 2006.

- [4] A. Kumar, M. Weimin, G. Ruifeng, "Three Gorges - Shanghai HVDC: Reinforcing interconnection between central and east China," *The 16th Conference of the Electric Power Supply Industry (CEPSI 2006)*, Mumbai, India, 6-10 November 2006.
- [5] V.G. Agelidis, G.D. Demetriades, N. Flourentzou, "Recent advances in high-voltage direct current power transmission systems," *Proceedings of National Power Electronics Conference of China, Xian*, September 23-26 2006.
- [6] The ABB Group, "ABB Website," Mars 2007, <http://www.abb.com> (last visit July 2007).
- [7] R. Billinton and R. Allan, *Reliability Evaluation of Power Systems*, 2nd ed. New York: Plenum publishing corporation, 1994, ISBN 0-306-45259-6.
- [8] R. Leelaruij, J. Setréus, L. Bertling, G. Olguin, "Availability assessment of the HVDC converter transformer system." to be presented at the 10th International Conference on Probabilistic Methods Applied to Power System (PMAPS), Puerto Rico, Maj 2008.
- [9] P. Pourbeik, M. Bahrman, E. John, W. Wong, "Modern countermeasures to blackouts," *Power and Energy Magazine, IEEE*, 2006.
- [10] V.K. Sood, *HVDC and Facts Controllers*. Kluwer Academic Publisher, 2004, ISBN 1-4020-7890-0.
- [11] A. Von Meier, *Electric Power Systems: A Conceptual Introduction*. IEEE computer society press, 2006, ISBN 0471178594.
- [12] J. Setréus, et al., "Study visit at the SwePol HVDC Link," Royal Institute of Technology (KTH), School of Electrical Engineering, Tech. Rep., November 2006, TRITA-EE 2006:063.
- [13] J. Paulinder, "Operation and control of HVDC links embedded in AC systems," Thesis for the degree of Licentiate, Chalmers University of Technology, Gothenburg, Sweden, 2003.
- [14] P. F. de Toledo, "Feasibility of HVDC for city infeed," Thesis for the degree of Licentiate, Department of Electrical Engineering, KTH, Stockholm, Sweden, 2003, TRITA-ETS-2003-11.
- [15] N. Mohan, T.M. Undeland, W.P. Robbins, *Power Electronics*. John Wiley and Sons, Inc, 2003, ISBN 0-471-42908-2.
- [16] R. Rudervall, J.P. Charpentier, R. Sharma, "High voltage direct current (HVDC) transmission systems technology review paper." Washington, D.C., USA: Energy Week 2000, March 78, 2000.
- [17] V. F. Lescale, "Modern HVDC: state of the art and development trends," in *Power System Technology, 1998. Proceedings. POWERCON '98. 1998 International Conference on*, vol. 1, Beijing, Aug. 1998, pp. 446-450.
- [18] IEEE Working Group I7, Reliability of HVDC Converter Stations, in the High Voltage Power Electronics Stations Subcommittee for the IEEE-PES Substations Committee, "IEEE Std 1240-2000, IEEE Guide for the evaluation of the Reliability of HVDC Converter Stations," IEEE, Tech. Rep., 2000, ISBN 0-7381-2509-9.
- [19] I. Vancers, D.J. Christofersen, A. Leirbukt, M.G. Bennett, "A Survey of the Reliability of HVDC Systems Throughout the World During 2001-2002," *CIGRÉ Working Group B4.04*, 2004.
- [20] CIGRÉ Study Committee 14-DC Links, #14-97 (WG 04-21), "Protocol for Reporting the Operational Performance of HVDC Transmission Systems," CIGRÉ, Tech. Rep., 1997.
- [21] C. R. Heising and R. J. Ringlee, "Prediction of reliability and availability of HVDC valve and HVDC terminal," *IEEE Transactions on Power Apparatus and Systems*, vol. 89, no. 4, pp. 619-624, Apr. 1970.
- [22] R. Billinton and V. Prasad, "Quantitative reliability analysis of HVDC transmission systems part I. spare valve assesment in mercury arc bridge configurations," *IEEE Transactions on Power Apparatus and Systems*, vol. 90, no. 3, pp. 1034-1046, May 1971.
- [23] R. Billinton and V. Prasad, "Quantitative reliability analysis of HVDC transmission systems part II composite system analysis," *IEEE Transactions on Power Apparatus and Systems*, vol. 90, no. 3, pp. 1047-1054, May 1971.
- [24] R. Billinton, S. Aboreshaid, M. Fotuhi-Firuzabad, "Well-being analysis for HVDC transmission systems," *IEEE Transactions on Power Systems*, 1996.
- [25] R. Billinton, A. Sankarkrishnan, "Adequacy assessment of composite power systems with HVDC links using Monte Carlo simulation," *IEEE Transactions on Power Systems*, 1994.
- [26] S. Kumganty, "HVDC transmission system models for power system reliability evaluation," *IEEE Wescanex '95 Proceedings*, 1995.
- [27] S. Kumganty, "Effect of HVDC Component Enhancement on the Overall System Reliability Performance," *IEEE Transactions on Power Delivery*, vol. 9, no. 1, January 1994.
- [28] R. Billinton, M. Fotuhi-Firuzabad, S.O. Faried, S. Aboreshaid, "Composite system reliability evaluation incorporating an HVDC link and a static synchronous series compensator," *Proceedings of the 2002 IEEE Canadian Conference on Electrical & computer Engineering*, 2002.
- [29] G. Desrochers, S. Lefebvre, M. Blanchard, B. Rioux, "A Method for Reliability Evaluation of D.C. Links," *CIGRÉ Report, 14(05) 1988 session*, 1988.
- [30] R. Billinton, M. Fotuhi-Firuzabad, S.O. Faried, "Reliability evaluation of hybrid multiterminal HVDC subtransmission systems," *IEEE Proceedings-Generation Transmission Distribution*, vol. 149, no. 5, September 2002.
- [31] R. Billinton, S. Aboreshaid, M. Fotuhi-Firuzabad, "A hybrid deterministic / probabilistic technique for HVDC system reliability evaluation," *Proceedings of the 1997 IEEE Conference on Communications, Power and Computing WESCANEXPII*, 1997.
- [32] R. Billinton, S. Aboreshaid, M. Fotuhi-Firuzabad, "Diagnosing the Health of Bulk Generation and HVDC Transmission Systems," *IEEE Transactions on Power Systems*, November 1997.
- [33] R. Billinton, S. Aboreshaid, M. Fotuhi-Firuzabad, "An approach for reliability evaluation of HVDC transmission systems using a well-being framework," *Energy Management and Power Delivery, 1998. Proceedings of EMPD '98.*, 1998.
- [34] R. Billinton, D.S. Ahluwalia, "Incorporation of a DC link in a composite system adequacy assessment - composite system analysis," *IEEE Proceedings-C*, May 1992.
- [35] M. Fotuhi-Firuzabad, R. Billinton, S.O. Faried, "Transmission system reliability evaluation incorporating HVDC links and FACTS devices," *Power Engineering Society Summer Meeting, 2001. IEEE*, 2001.
- [36] C. Grigg, P. Wong, P. Albrecht, R. Allan, M. Bhavaraju, R. Billinton, Q. Chen, C. Fong, S. Haddad, S. Kuruganty, W. Li, R. Mukerji, D. Patton, N. Rau, D. Reppen, A. Schneider, M. Shahidehpour, and C. Singh, "The IEEE reliability test system-1996. a report prepared by the reliability test system task force of the application of probability methods subcommittee," *IEEE Transactions on Power Systems*, vol. 14, no. 3, pp. 1010-1020, Aug. 1999.
- [37] R. Billinton, D.S. Ahluwalia, "Incorporation of a DC link in a composite system adequacy assessment - DC system modelling," *IEE Proceedings-C*, May 1992.

Johan Setréus (S'06) was born in Stockholm 1980. He received his M.Sc. in electrical engineering in 2006, from KTH - the Royal Institute of Technology, Stockholm, Sweden. He has been held a Ph.D. position at KTH School of Electrical Engineering since 2006 within the research group on reliability-centered asset management (RCAM). The title of his Ph.D. project is "Reliability modeling and design for complex power systems", which will investigate possible benefits and challenges of introducing new technologies for the power system design e.g. HVDC. His research interests also include techniques and methods to combine traditional deterministic criterions in the transmission system with probabilistic methods.

Lina Bertling (S'98-M'02) was born in Stockholm in 1973. She received the Ph.D., and Tech. Lic. degree in Electric power systems in 2002 respectively 1999, and the M.Sc. degree in Systems engineering in 1997, all from KTH - the Royal Institute of Technology, Stockholm, Sweden. She was a visiting postdoctoral student at the University of Toronto associated with Kinectrics Inc. during 2002/2003. She is currently engaged at KTH School of Electrical Engineering as Assistant Professor. Since 2003 she has been working as a lecturer and research leader at KTH. She was the general chair of the 9th International conference on probabilistic methods applied to power systems (PMAPS) in Stockholm, in 2006. Her research interests are in: power system maintenance planning and optimization including reliability-centered maintenance (RCM) methods, reliability modeling and assessment for complex systems, and lifetime- and reliability modeling for electrical components. Dr. Bertling is a member of the board for the IEEE Sweden Section, and the IEEE Power Engineering Society (PES) Subcommittee on Risk, Reliability, and Probability Applications (RRPA), and the IEEE PES Committee on Power System Planning and Implementation. She leads an IEEE PES Task Force on distribution system reliability.